

BALL FLOAT AIR (GAS) DRAIN TRAP

AGH29/AGU29

USER'S MANUAL



 **MIYAWAKI INC.**

SAFETY GUIDE

The models AGH29 and AGU29 are mechanical ball float air and gas traps.
In order to get maximum benefit from these products, be sure to read this manual before installing them.

The following warnings and cautions are shown at appropriate places in this manual.



Failure to observe this type of precaution may lead to serious injury or death.



Failure to follow this type of precaution can lead to injury or damage to equipment and property.

Table of Contents

1	SPECIFICATIONS AND MARKINGS	1
2	CONSTRUCTION DETAILS	2
3	INSTALLATION	4
4	OPERATION	5
5	MAINTENANCE	6
6	TROUBLESHOOTING	8
7	WARRANTY	9
8	SERIAL NUMBER (S. No.) DESIGNATION	10
9	GUIDANCE FOR READING SPECIAL PRODUCT NAME	11

1 SPECIFICATIONS AND MARKINGS



WARNING

Be sure not to use this product at higher pressures than the specified maximum allowable pressure (PMA) or at temperatures higher than the specified maximum allowable temperature (TMA).

Check each item to avoid misuse of the product.

- 1) Max. allowable pressure (PMA):
AGH29(W)-16 , AGU29(W)-16 - 3.0 MPa (435 psig)
AGH29(W)-40 , AGU29(W)-40 - 4.5 MPa (652 psig)
 - 2) Max. allowable temperature (TMA): 400 °C (752 °F)
 - 3) Maximum differential pressure (Δ PMX):
AGH29(W)-16, AGU29(W)-16 - 1.6 MPa (232 psig)
AGH29(W)-40, AGU29(W)-40 - 4.0 MPa (580 psig)
 - 4) Max. operating temperature (TMO): 400 °C (752 °F)
 - 5) Size:
AGH29 and AGU29 : 15 mm – 50 mm (1/2" – 2")
AGH29W and AGU29W : 15 mm – 25 mm (1/2" – 1")
 - 6) Year of production: The two leftmost digits in the four-digit or nine-digit "S. No." are the last two digits of the year of production.
 - 7) Flow direction: Shown by an arrow
 - 8) Body material:
AGH29 - Cast steel SCPH2
AGU29 - Stainless steel SCS13A
 - 9) Model: Showing the product model name
- Some pictures and illustrations in this manual are examples of AGH29 models. For more details regarding dimensions and other specifications, please refer to the catalog.

The models AGH29 and AGU29 fully comply with the requirements of the European Pressure Equipment Directive 2014/68/EU. They are classified according to Article 13 and Annex II of the PED by category I of the Fluid Group 2. The CE marking is affixed to the products.

2 CONSTRUCTION DETAILS

AGH29:

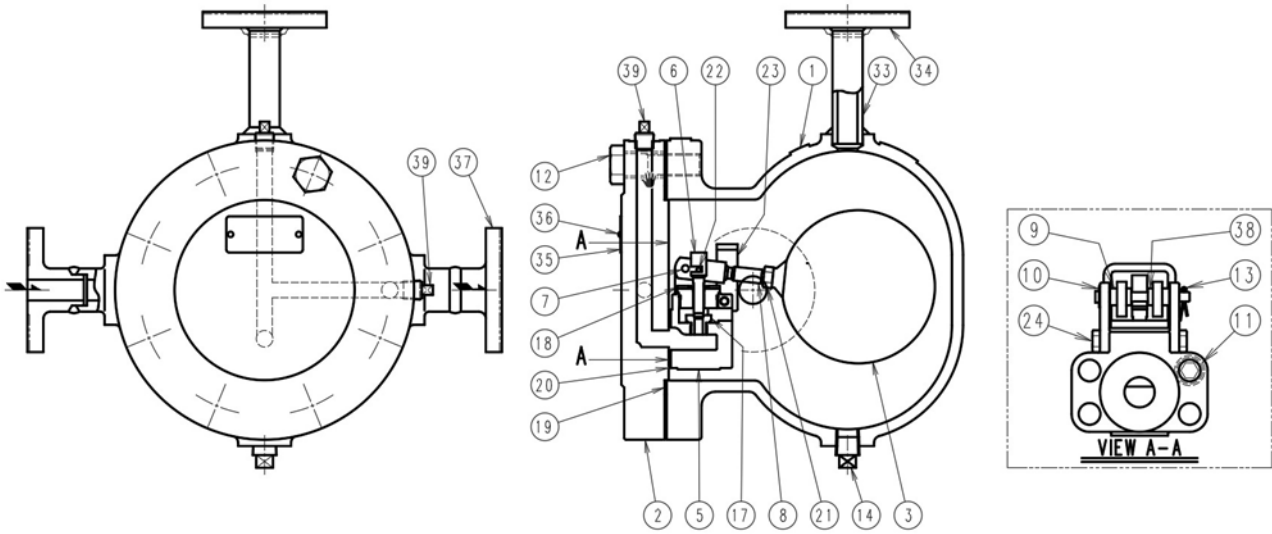

AGH29W:

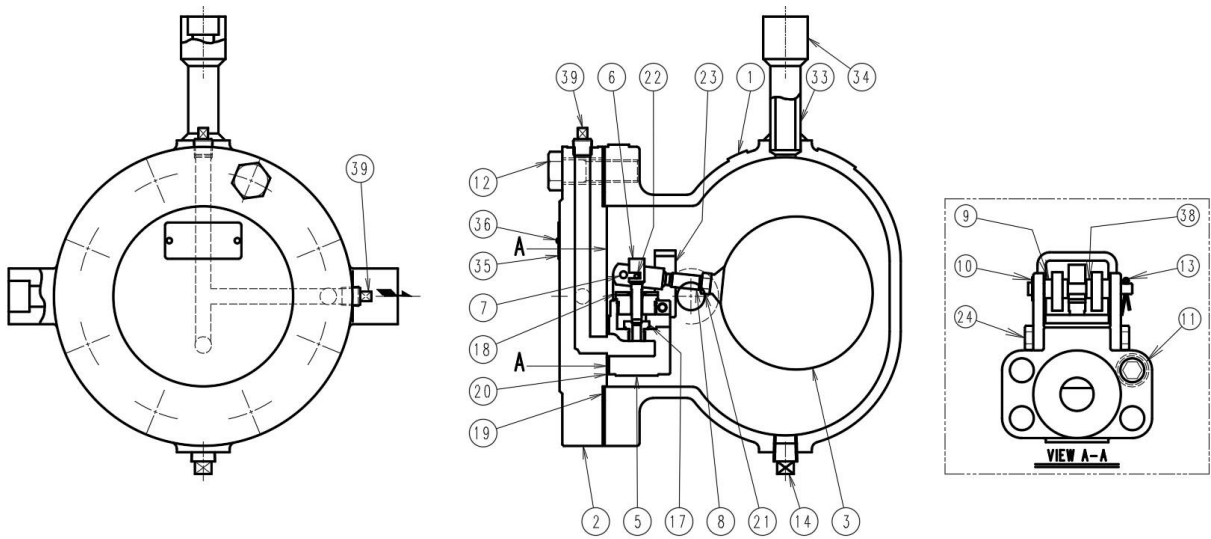

AGU29:

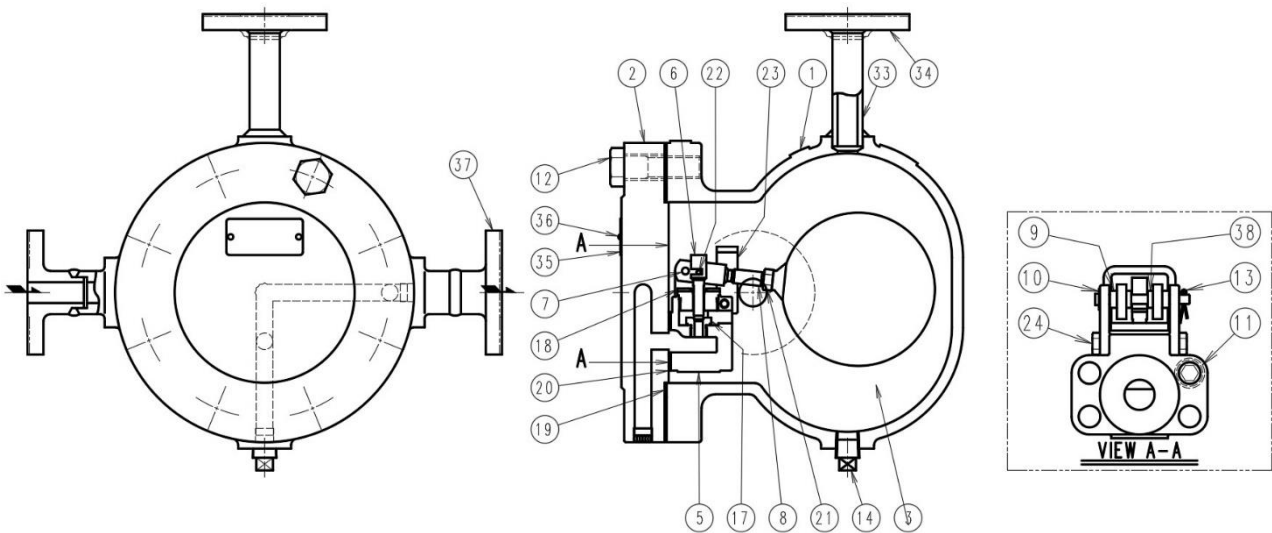

AGU29W:

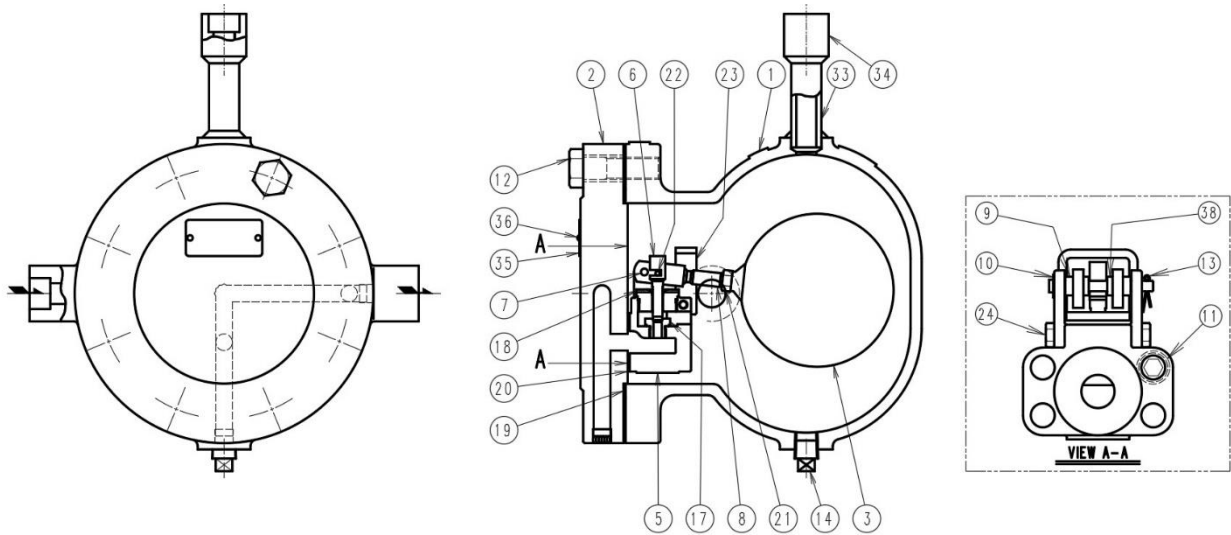

- | | | |
|-----------------|-------------------|-------------------------------|
| 1. Body | 12. Cover Bolt | 24. Bolt |
| 2. Cover | 13. Pin | 33. Pipe |
| 3. Float | 14. Body Plug | 34. Flange (AGH29/AGU29) |
| 5. Holder | 17. Valve Seat | 34. Coupling (AGH29W/AGU29W) |
| 6. Valve | 18. Bush | 35. Name Plate |
| 7. Pin | 19. Cover Gasket | 36. Rivet |
| 8. Lever | 20. Holder Gasket | 37. Flange (AGH29/AGU29) |
| 9. Collar | 21. Nut | 38. Spacer |
| 10. Washer | 22. Pin | 39. Cover Plug (AGH29/AGH29W) |
| 11. Holder Bolt | 23. Stopper | |

3 INSTALLATION



WARNING

Pay very careful attention when working in hazardous environments. There is a risk of explosion and the possibility of dangerous gases leaking. Always check whether the pipeline contains flammable, high pressure or high temperature materials before starting to work.

- Make sure that isolation valves are installed on both the upstream and downstream lines.



CAUTION

Before installing the product, open both isolation valves and the bypass valve, if one exists, to blow out any debris or dirt inside the pipeline. After blowing out the line, before starting to work, close the isolation valves and allow time for the temperature to drop to a safe working temperature.

When installing the product, be sure to leave clearance for maintaining it.

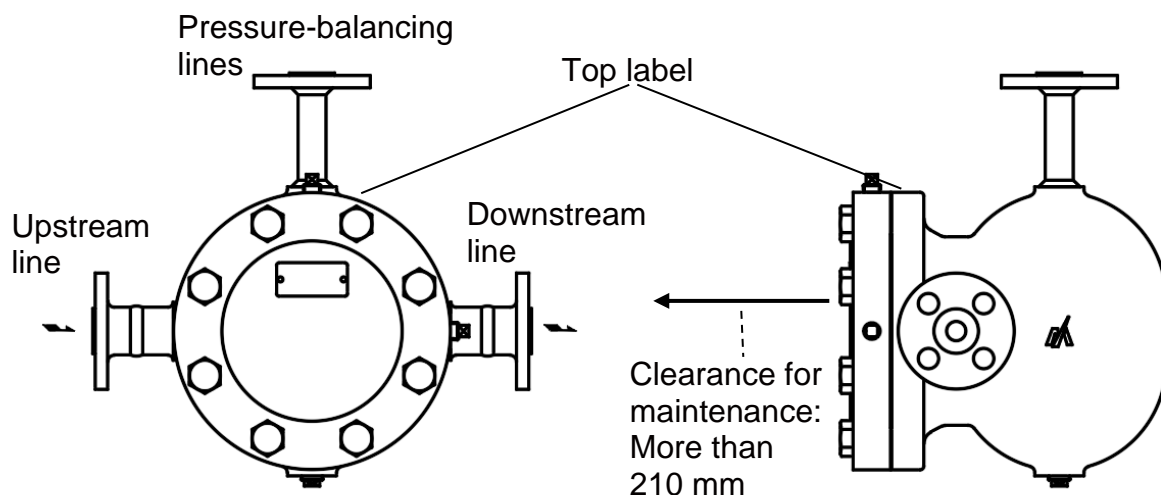

- 1) Remove the dustproof seals covering both connections.
✘Products shipped in plastic bags may not have dustproof seals.
- 2) Check the flow direction indicated on the side of the body.
- 3) The Models AGH29 and AGU29 must be installed horizontally. Be sure not to install the products upside-down in a horizontal line, as it will cause the trap to malfunction.
- 4) Never confuse inlet with outlet.
- 5) Install the trap at the lowest point of the air or gas using equipment. Be sure to maintain a slight slope of the pipe, so that any condensate will flow smoothly to the trap.
- 6) Make sure, that a pressure-balancing line will be piped between the air trap and the equipment which will be drained.

4 OPERATION



CAUTION

Before starting operation, open the bypass valve or blow valve completely and blow off the scale in the piping.

4.1 Operation procedure

- 1) After blowing off the scale from the piping, close the bypass valve or blow valve.
- 2) Open the isolation valve on the air trap outlet side.
- 3) Open the isolation valve on the air trap inlet side.
- 4) Open the isolation valve of the pressure-balancing line of the air trap.

4.2 Stop procedure

- 1) Close the isolation valve on the air trap inlet side.
- 2) Close the isolation valve of the pressure-balancing line of the air trap.
- 3) Close the isolation valve on the air trap outlet side.

* When stopping for a long time, completely drain the condensate from the piping and air trap and close the valves before and after the air trap.

5 MAINTENANCE



WARNING

- Before removing the air trap from the pipe or disassembling it, be sure to close the isolation valves. Then, release the residual pressure from the trap body (make sure that the pressure in the air trap body is equal to the atmospheric pressure). After it has fully cooled down (after the temperature of the air trap body has reached ambient temperature), confirm for safe conditions and then begin to work.
- Even when the isolation valves are closed, there may be residual internal pressure due to leaks from the isolation valves. Therefore, be very careful.



CAUTION

- When replacing parts, make sure the replacement parts are supplied by MIYAWAKI.

The performance of air traps deteriorates gradually over time due to wear, corrosion or dirt accumulating around the valve and the valve seat. Please conduct periodic diagnosis of traps in order to keep the equipment working well.

5.1 Repairs

When a trap fails, it is necessary to clean the internal parts and to replace damaged parts. Take the failed trap apart following the steps below.

5.1.1 Disassembling the trap

- 1) Loosen the cover bolts (12). Remove all inner parts together with the cover (2).
- 2) Firm the cover (2) with a vise and unscrew the holder bolts (11). Then you can take off the valve unit.
- 3) Dismantle the pin (13) and take out the pin (7).
- 4) Now take off the lever (8) and the valve (6).
- 5) Firm the lever (8) with a vise and unscrew the nut (21). Now the float (3) will come apart.

After inspection of each part and cleaning, assemble in the opposite way of disassembling.



CAUTION

Clean the body (1) and cover (2) with care not to damage the sealing surfaces. Scratches on the sealing surfaces may cause leakage.

Torque table

Model	Parts	Tools	Size	Torque
AGH29	Holder Bolt (11)	Hexagon key	8 mm (0.32")	50 N·m
AGH29	Cover Bolt (12)	Torque Wrench	24 mm (0.95")	100 N·m
AGU29	Holder Bolt (11)	Hexagon key	8 mm (0.32")	50 N·m
AGU29	Cover Bolt (12)	Torque Wrench	24 mm (0.95")	80 N·m



CAUTION

When reassembling always replace the gaskets (19) and (20) with new ones. Tighten the holder bolts (11) and cover bolts (12) evenly crosswise.

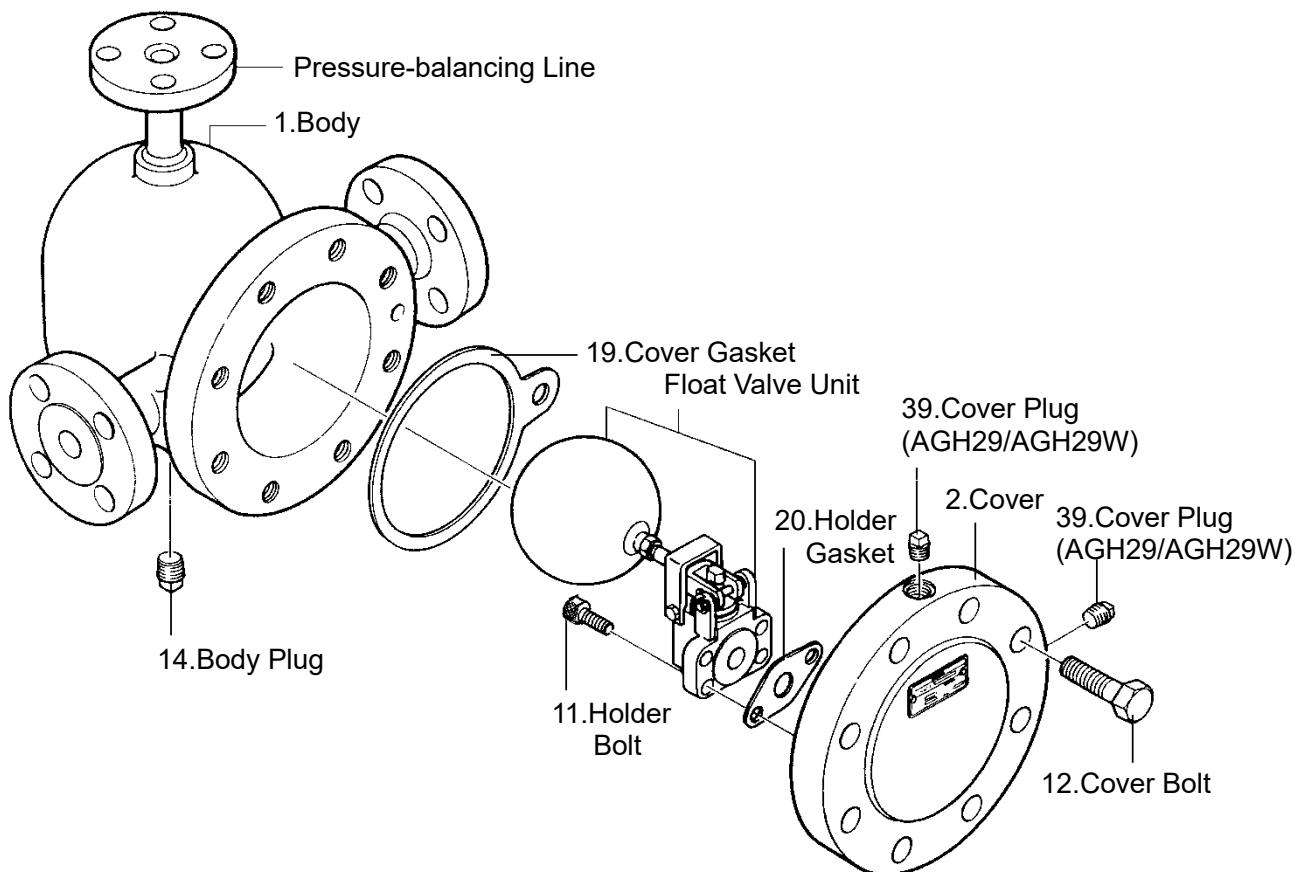

6 TROUBLESHOOTING

Problem		Possible cause	Solution
Air (gas) leaks or blows through.		Foreign material such as scale and/or dirt lodged between valve (6) and valve seat (17).	Clean the valve (6) and the valve seat (17).
		The valve (6) and/or the valve seat (17) are damaged, worn or corroded.	Replace the valve unit.
		The cover gasket (19) and/or holder gasket (20) are worn.	Replace the gaskets.
		Wrong installation position	Change the installation so that the top label should face up.
		Wrong installation direction	Make sure the arrow on the main body matches the flow direction of the fluid.
Air (gas) leaks from the body.	From between the body and cover	The cover bolts (12) are loose or uneven tightened.	Retighten them.*1
		Damage, erosion or deterioration of the cover gasket (19).	Replace the cover gasket (19).
		The gasket sealing surface on the body (1) or cover (2) is damaged.	Replace the body (1) with a new one, or replace the cover (2).
	From between the body/cover and plug	The body plug (14) is loose.	Retighten the body plug (14).
		(AGH29) The cover plug (39) is loose.	Retighten the cover plug (14).
Condensate logging and/or no discharge		The valve seat (17) is clogged.	Clean the valve seat (17).
		The float (3) is damaged or filled up with water.	Replace the float (3).
		The inlet valve is closed.	Open the inlet valve.
		The strainer at the inlet pipe side is clogged.	Clean the strainer.
		The operating pressure is too high.	Change the operating pressure or select a trap for higher pressure.
		The capacity of the trap is too low.	Check the operating conditions and select a trap with higher capacity.
		Scale and/or dirt lodged between valve (6) and valve seat (17).	Clean the valve (6) and the valve seat (17).
		Condensate cannot flow naturally into the trap.	Change the piping.
		Lack of differential pressure.	Check the operating conditions.
		Installing pressure-balancing line is wrong	Correct the installation line.

*1: Refer to the torque table in Section 5, "Maintenance" to retighten the parts to the correct torque.

7 WARRANTY

7.1 Warranty period

The warranty period is 18 months after shipment or 12 months after installation, whichever occurs first.

7.2 Details of the warranty

If the product stops working correctly within the warranty period, we will repair or replace the product free of charge if the cause of the trouble is not one of the following items.

- 1) The precautions described in this manual were not observed.
- 2) User's errors or mistakes such as an inappropriate installation or incorrect handling, or an excessively large impact caused by dropping
- 3) Problems caused by devices or equipment other than MIYAWAKI's, or a disallowed use environment
- 4) When a repair or modification has been performed by anyone other than MIYAWAKI or people who are authorized to make such repairs
- 5) Intrusion of salt or other substances that promote significant rust or corrosion or problems from fluids that contain the same substances
- 6) Consumable parts such as Packing, Gasket, O-ring, Diaphragm, etc.
- 7) Attachment or accumulation of foreign matter in the pipe, such as dust and scale
- 8) Problems from fires, natural disasters, or other force majeure which is not MIYAWAKI's responsibility

7.3 Warranty limitation

The remedy available under the warranty shall not exceed the sales price of the products delivered, for any cause whatsoever.

8 SERIAL NUMBER (S. No.) DESIGNATION

The following 4-digit or 9-digit “S. No.” is displayed on the product.

- For 4-digit display

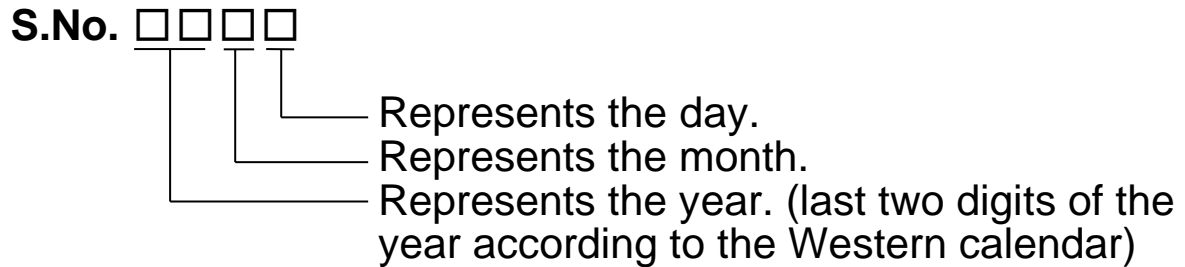

Example of serial number designation

1 7 1 1 → Jan.1, 2017

2 9 X M → Oct. 21, 2029

- For 9-digit display

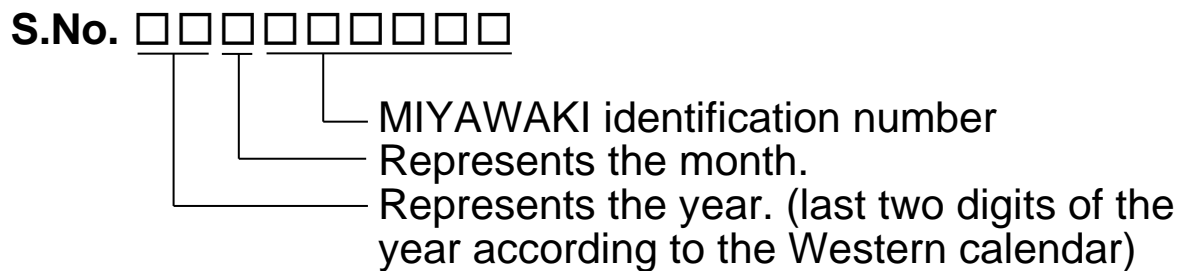

Example of serial number designation

1 7 1 1 2 C 0 2 0 → Jan., 2017

2 9 X 0 5 M 0 5 0 → Oct., 2029

Month designation system

Month	1	2	3	4	5	6	7	8	9	10	11	12
Symbol	1	2	3	4	5	6	7	8	9	X	Y	Z

Day designation system

Day	1	2	3	4	5	6	7	8	9	10	11	12
Symbol	1	2	3	4	5	6	7	8	9	A	B	C

Day	13	14	15	16	17	18	19	20	21	22	23	24
Symbol	D	E	F	G	H	J	K	L	M	N	O	P

Day	25	26	27	28	29	30	31
Symbol	Q	R	S	T	U	V	W

9 GUIDANCE FOR READING A SPECIAL PRODUCT NAME

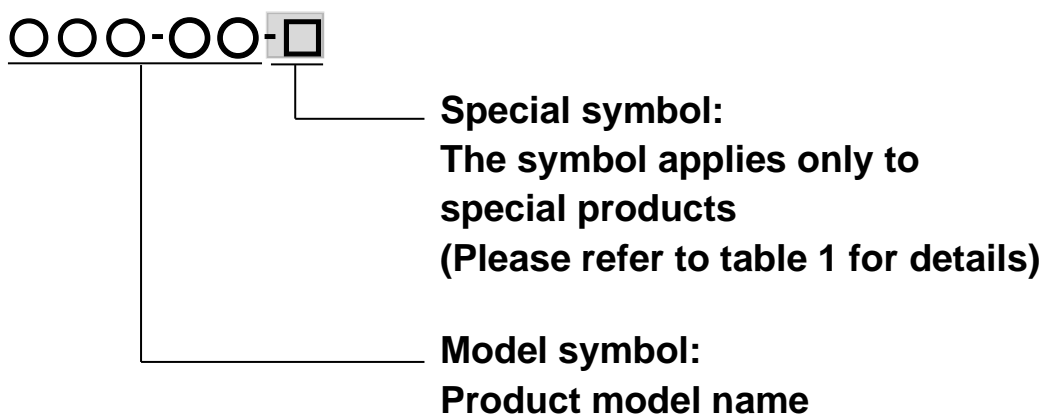

Table 1 Symbol description

Suffix	Special contents
A	Trap for high-pressure gas installed property (only for Gas Trap)
C	Blow valve attached
K	Change of gasket
L	Special face to face dimension
M	Change of parts material
P, T	Change of operating pressure, temperature, condensate capacity, etc.
R	Change of screen mesh
V	Change of air vent
X	Other than mentioned above or complex of special contents above

-
- For any questions about the product that you purchased or about the details in this user's manual, please contact the following.
 - © 2024 MIYAWAKI INC.
This user's manual may not be reproduced or copied in whole or in part, without the written consent of MIYAWAKI INC.
 - Some special specifications of the product may found to be different from the ones in the user's manual. If you have any question, please contact MIYAWAKI, our local authorized agent, or the company where you purchased the product.
 - In the interest of the development and improvement of our products, MIYAWAKI Inc. reserves the right to change the specification of the products without prior notice.
-



If you need any assistance regarding this manual, please contact MIYAWAKI INC.'s International Sales Dept. or its local representative. By scanning QR Code, you can access inquiry form.



INTERNATIONAL SALES DEPT.
2-1-30, Tagawakita, Yodogawa-ku, Osaka, 532-0021, Japan
Tel: +81-6-6302-5549
www.miyawaki-inc.com/en e-mail: export@miyawaki-inc.co.jp

EU Importer and Authorized representative:



Birnbaumsmühle 65, 15234 Frankfurt (Oder), Germany
Tel: +49-335-4007-0097
www.miyawaki.de e-mail: info@miyawaki.de

China Importer and Authorized representative:



Room 902, Building 8, Huaqing Chuangzhi Park, No.3 Qingyan Road, Huishan District,
Wuxi City Jiangsu Province, China
Tel: +86-510-8359-5125
www.miyawaki-inc.com.cn e-mail: mywkwest@miyawaki-inc.com.cn