

**DOUBLE-PORTED BALANCE-VALVE
BALL FLOAT STEAM TRAP**

G3N, G5

USER'S MANUAL



G3N model



G5 model

 **MIYAWAKI INC.**

SAFETY GUIDE

The models G3N and G5 are ductile cast iron ball float steam traps with an integrated membrane capsule automatic air vent. They are designed for large condensate capacities.

In order to get maximum benefit from this product, be sure to read this manual before installing it.

The following warnings and cautions are shown at appropriate places in this manual.



Failure to observe this type of precaution may lead to serious injury or death.



Failure to follow this type of precaution can lead to injury or damage to equipment and property.

Table of Contents

1. SPECIFICATIONS AND MARKINGS	1
2. CONSTRUCTION DETAILS	2
3. INSTALLATION	4
4. OPERATION	5
5. MAINTENANCE	6
6. TROUBLESHOOTING	9
7. WARRANTY	10
8. SERIAL NUMBER DESIGNATION	11
9. GUIDANCE FOR READING SPECIAL PRODUCT NAME	12

1 SPECIFICATIONS AND MARKINGS



WARNING

Be sure not to use this product at higher pressures than the specified maximum operating pressure (PMO) or at temperatures higher than the specified maximum operating temperature (TMO).

The following items are displayed on the name plate or the side of the product. Check each item to avoid misuse of the product.

- (1) Maximum allowable pressure (PMA): 1.6 MPa (232 psig)
 - (2) Maximum allowable temperature (TMA): 250 °C (482 °F)
 - (3) Maximum operating pressure (PMO):

G3N-10, G3N-10R	1.0 MPa (145 psig)
G3N-16, G3N-16R	1.6 MPa (232 psig)
G5-10, G5-10R	1.0 MPa (145 psig)
G5-16, G5-16R	1.6 MPa (232 psig)
 - (4) Maximum operating temperature (TMO): 235 °C (455 °F)
 - (5) Sizes:

G3N-10, G3N-16	40 mm (1 1/2")
G3N-10R	40 mm (1 1/2") – 80 mm (3")
G3N-16R	25 mm (1 ") – 80 mm (3")
G5-10, G5-16	50 mm (2")
G5-10R, G5-16R	50 mm (2") – 100 mm (4")
 - (6) Year of production: The two leftmost digits in the four-digit or nine-digit 'S. No.' are the last two digits of the year of production.
 - (7) Flow direction: Shown by an arrow.
 - (8) Body material: Ductile cast iron FCD450
 - (9) Model symbol: Showing the product name
- Some pictures and illustrations in this manual are examples of the a.m. models. For more details regarding dimensions and other specifications, please refer to the catalog.

The models G3N and G5 fully comply with the requirements of the European Pressure Equipment Directive 2014/68/EU.

The products G3N-10R and G3N-16R (1" – 2 1/2") are classified according to Article 4, Section 3 of the PED, which does not allow to bear the CE marking.

The products G3N-10R and G3N-16R (3") and all sizes of the model G5 are classified according to Article 13 and Annex II of the PED by category I of the Fluid Group 2. The CE marking is affixed to the products.

2 CONSTRUCTION DETAILS

G3N

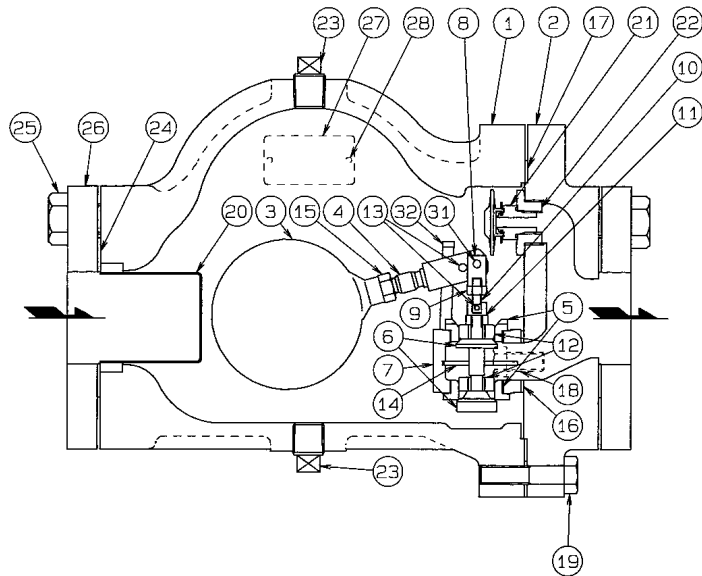

G3N-R

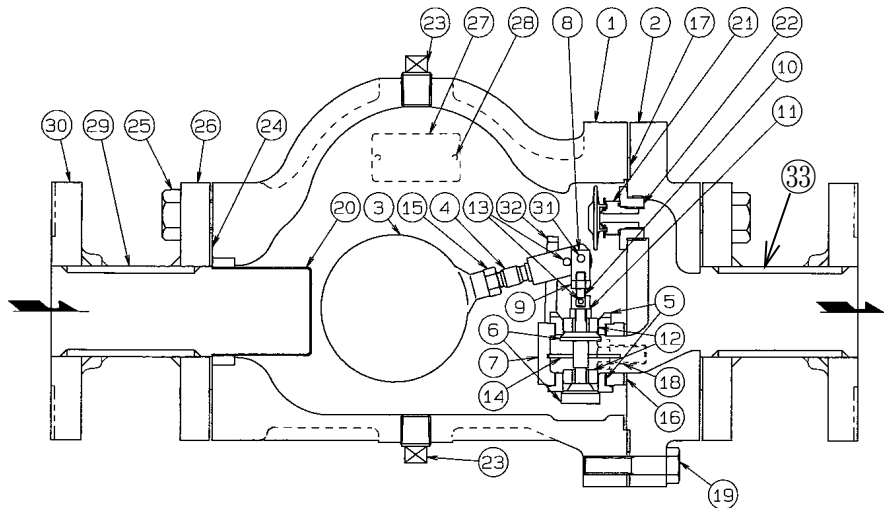

- | | | |
|---------------|-------------------|---------------------------------|
| 1. Body | 12. Guide Wing | 23. Body Plug |
| 2. Cover | 13. Pin | 24. Flange Gasket |
| 3. Float | 14. Baffle Plate | 25. Flange Bolt |
| 4. Lever | 15. Nut | 26. Flange |
| 5. Valve Seat | 16. Holder Gasket | 27. Name Plate |
| 6. Valve | 17. Cover Gasket | 28. Rivet |
| 7. Holder | 18. Holder Bolt | 29. Pipe / Reducer (only G3N-R) |
| 8. Lever Nut | 19. Cover Bolt | 30. Flange (only G3N-R) |
| 9. Nut | 20. Screen | 31. Pin |
| 10. Connector | 21. Air Vent | 32. Stopper |
| 11. Nut | 22. Bush | 33. Pipe / Reducer (only G3N-R) |

G5

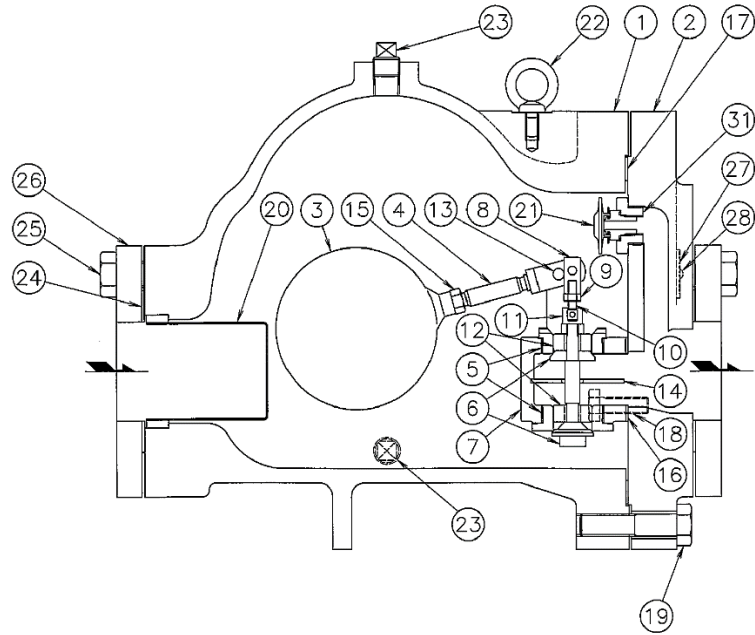

G5-R

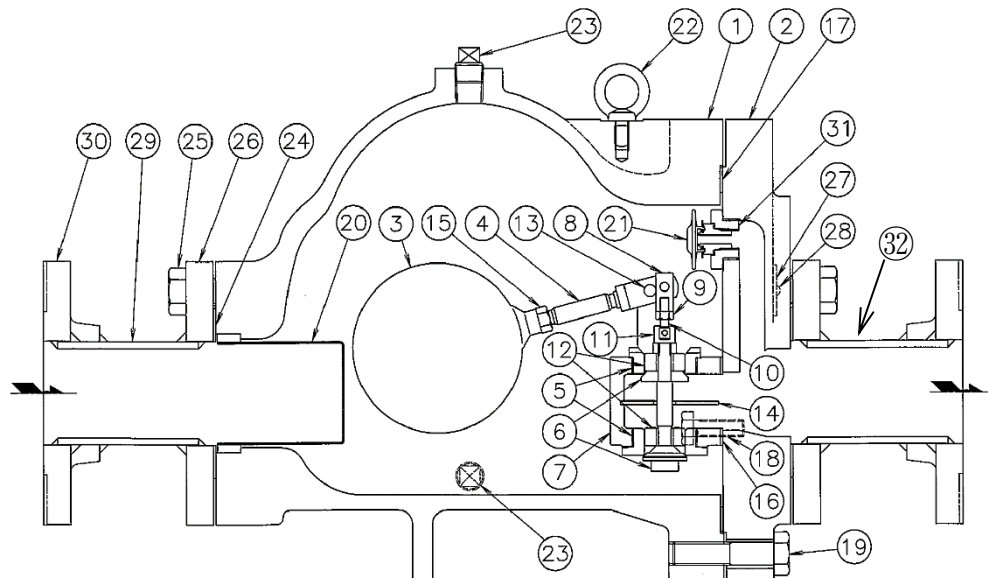

- | | | | | | |
|-----|------------|-----|---------------|-----|--------------------------|
| 1. | Body | 12. | Guide Wing | 23. | Body Plug |
| 2. | Cover | 13. | Pin | 24. | Flange Gasket |
| 3. | Float | 14. | Baffle Plate | 25. | Flange Bolt |
| 4. | Lever | 15. | Nut | 26. | Flange |
| 5. | Valve Seat | 16. | Holder Gasket | 27. | Name Plate |
| 6. | Valve | 17. | Cover Gasket | 28. | Rivet |
| 7. | Holder | 18. | Holder Bolt | 29. | Pipe/Reducer (only G5-R) |
| 8. | Lever Nut | 19. | Cover Bolt | 30. | Flange (only G5-R) |
| 9. | Nut | 20. | Screen | 31. | Bush |
| 10. | Connector | 21. | Air Vent | 32. | Pipe/Reducer (only G5-R) |
| 11. | Nut | 22. | Eyebolt | | |

3 INSTALLATION



WARNING

Pay very careful attention when working in hazardous environments. There is a risk of explosion and the possibility of dangerous gases leaking. Always check whether the pipeline contains flammable, high pressure or high temperature materials before starting to work.

- Make sure that isolation valves are installed on both the upstream and downstream lines.



CAUTION

- Before installing the product, open both isolation valves to blow out any debris or dirt inside the pipeline.
- After blowing out the line, before starting to work, close the isolation valves and allow time for the temperature to drop to a safe working temperature.
- When installing the product, be sure to leave clearance for maintaining it.
- The models G3N and G5 are heavy products. You are recommended to reinforce lines to support the product's weight.

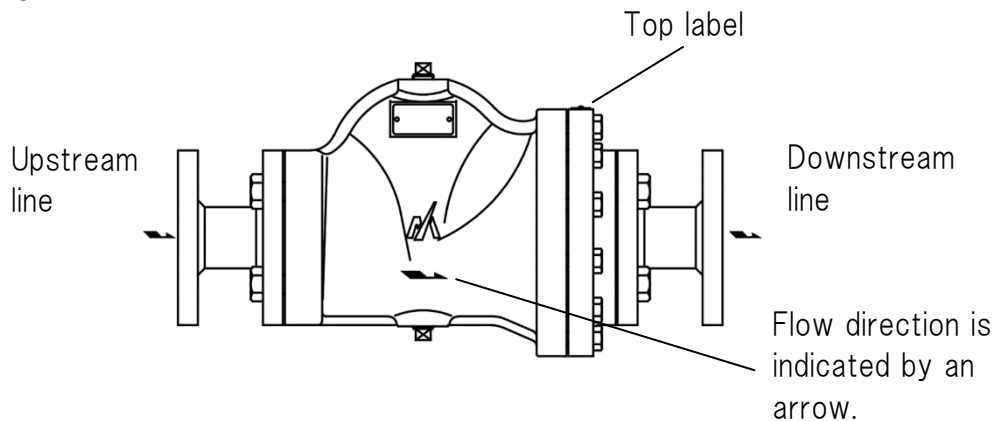

- (1) Remove the dustproof seals covering both connections.
※Products shipped in plastic bags may not have dustproof seals.
- (2) Check the flow direction indicated on the side of the body.
- (3) When installing the models G3N and G5, install it so that the flow from the upstream line to the downstream line is horizontal and the top label is on the top side of the body. Install the products at the end of a pipe that is angling down, so that condensate flows into the steam trap easily.
- (4) Open the isolation valve on the upstream line slowly and make sure the product works normally.

4 OPERATION



CAUTION

Before starting operation, open the bypass valve or blow valve completely and blow off the scale in the piping.

4.1 Operation procedure

- 1) After blowing off the scale from the piping, close the bypass valve or blow valve.
- 2) Open the isolation valve on the trap outlet side.
- 3) Open the isolation valve on the trap inlet side.

4.2 Stop procedure

- 1) Close the isolation valve on the trap inlet side.
- 2) Close the isolation valve on the trap outlet side.

* When stopping for a long time, completely drain the condensate from the piping and trap and close the valves before and after the trap.

5 MAINTENANCE



WARNING

- Before removing the trap from the pipe or disassembling it, be sure to close the isolation valves. Then, release the residual pressure from the trap body (make sure that the pressure in the main body is equal to the atmospheric pressure). After it has fully cooled down (after the temperature of the main body has reached ambient temperature), confirm for safe conditions and then begin to work.
- Even when the isolation valves are closed, there may be residual internal pressure due to leaks from the isolation valves. Therefore, be very careful.



CAUTION

- When replacing parts, make sure the replacement parts are supplied by MIYAWAKI.

The performance of steam traps deteriorates gradually over time due to wear, corrosion or dirt accumulating around the valve and the valve seat. Please conduct periodic diagnosis of traps in order to keep steam control systems and equipment working well.

5.1 Tools for Diagnosing Steam Traps

■ Dr. Trap

Dr. Trap is a sophisticated steam trap management system for diagnosing steam traps automatically by measuring the vibration and temperature of the steam trap. Survey results are stored in the testing equipment and transferred to a steam trap analysis software. The software aggregates and analyses steam trap survey data, identifying faulty steam traps, providing steam loss and financial loss data, estimating CO₂ emissions corresponding to leaking steam traps and providing many other analyze possibilities to manage the steam trap population easily.

■ Dr. Trap Jr.

Dr. Trap Jr. is an inexpensive and easily to handle steam trap diagnostic system consisting of an ultrasonic checker, temperature probe and a sophisticated analysis software. The software allows to determine the condition of a steam trap, to estimate steam and financial losses and the related CO₂ emissions.

For more details, please, check our homepage:

<https://www.miyawaki.net/en/products/steam-trap-management-system>

or ask our local representative.

5.2 Repairs

When a trap fails, it is necessary to clean the internal parts and to replace damaged parts. Take the failed trap apart following the steps below.

5.2.1 Disassembling the trap

- 1) Loosen the flange bolts (25) and remove the flange (26).
- 2) Take off the screen (20).
- 3) Now loosen the cover bolts (19) and remove the cover (2) from the body (1). Together with the cover (2) you will take off the complete inner unit.
- 4) Firm the cover (2) with a vice and unscrew the holder bolts (18) with a wrench. Now the complete valve unit including the float (3) comes apart. The valve unit consists of the following parts: lever (4), valve seat (5), valve (6), holder (7), lever nut (8), nut (9), connector (10), nut (11), guide wing (12), pin (13), baffle plate (14) and nut (15).
- 5) The float (3) and the air vent (21) can be removed with a wrench.

Clean and check all parts and take the appropriate measures, as described in Section 6, "Troubleshooting".

If the Float (3) is damaged, loosen the Nut (15) of the Lever (4), and unscrew the Float (3) by hand. Then replace it with a new one. If the Valve (6) and Valve Seat (5) are worn or defect, replace the whole valve unit.

Reassemble the parts as follows, reversing the procedure used to disassemble them. Refer to the torque table to use the correct torque for each part.

5.2.2 Reassembling the trap

Reassemble the parts in the reverse order as disassembling. Refer to the torque table to use the correct torque for each part. Replace the gaskets (16), (17) and (24) with new ones.

Torque table

Model	Parts Name	Parts-No.	Across the flats	Torque
G3N, G3N-R	Holder Bolt	18	14 mm (0.56")	30 N·m
	Cover Bolt	19	17 mm (0.68")	40 N·m
	Air Vent	21	17 mm (0.68")	25 N·m
	Bush	22	32 mm (1.26")	130 N·m
	Flange Bolt	25	24 mm (0.95")	80 N·m
G5, G5-R	Holder Bolt	18	17 mm (0.68")	40 N·m
	Cover Bolt	19	22 mm (0.87")	60 N·m
	Air Vent	21	17 mm (0.68")	25 N·m
	Bush	31	32 mm (1.26")	130 N·m
	Flange Bolt	25	24 mm (0.95")	80 N·m

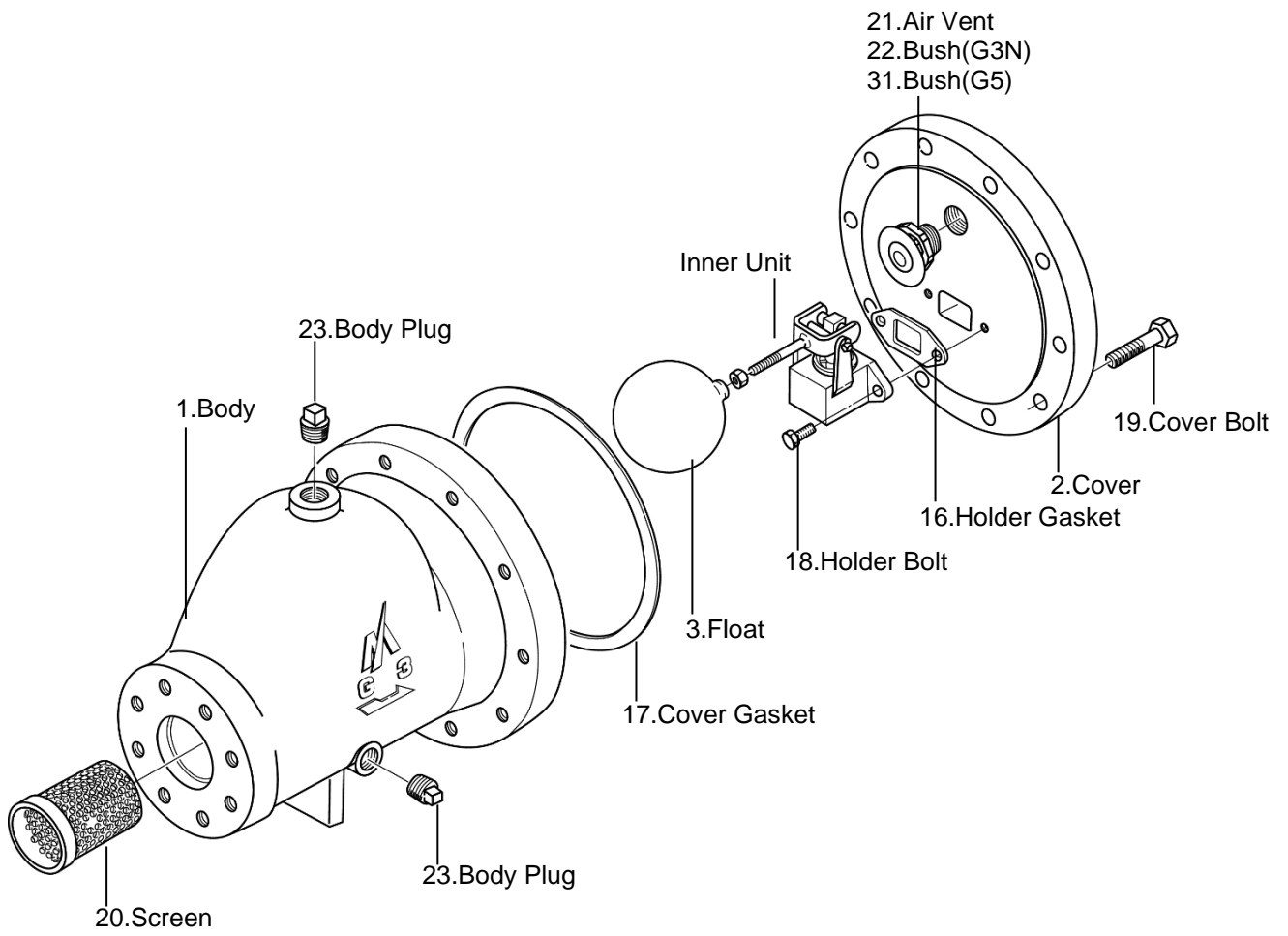

6 TROUBLESHOOTING

Problem	Possible cause	Solution
Steam leaks or blows through.	Foreign material such as scale or dirt is stuck between the valve (6), the valve seat (5) and/or the holder (7) of the valve unit.	Disassemble the valve unit and remove the material.
	The valve (6), the valve seat (5) and/or the holder (7) are damaged, worn or corroded.	Replace the valve unit.
	The holder bolts (18) are loose.	Retighten the holder bolts (18). *1
	The holder gasket (16) is damaged.	Replace the holder gasket (16).
	Foreign material such as scale or dirt sticks to the air vent (21).	Disassemble the air vent (21) unit and remove the material.
	The air vent (21) is damaged.	Replace the air vent (21). *2
	The sealing surfaces of the valve or the valve seat in the air vent (21) are damaged, worn or corroded	Replace the air vent (21). *3
	Wrong installation direction	Make sure the arrow on the main body matches the flow direction of the fluid.
Steam leaks from the body.	The cover bolts (19) or flange bolts (25) are loose.	Retighten them. *4
	Damage, erosion or deterioration of the cover gasket (17).	Replace the cover gasket (17).
	The gasket sealing surface of the body (1) or cover (2) is damaged.	Replace the body (1) with a new one, or replace the cover (2).
Insufficient condensate discharged or no condensate discharged	The screen (20) is clogged.	Clean the screen (20).
	Foreign material such as a scale or dirt is stuck in the valve seat (5).	Clean the valve seat (5).
	The float (3) is damaged.	Replace the float (3).
	The air vent (21) is damaged.	Replace the air vent (21).
	Wrong installation position	Correct the installation position.
	The steam pressure exceeds the specified maximum operating pressure.	Lower the pressure or replace the trap with one that has a higher maximum operating pressure.
	Insufficient condensate capacity.	Replace the trap with a larger capacity trap.

*1, *2, *3 and *4: Refer to the torque table in Section 5, "Maintenance" to retighten the parts with the correct torque.

7 WARRANTY

7.1 Warranty period

The warranty period is 18 months after shipment or 12 months after installation, whichever occurs first.

7.2 Details of the warranty

If the product stops working correctly within the warranty period, we will repair or replace the product free of charge if the cause of the trouble is not one of the following items.

- 1) The precautions described in this manual were not observed.
- 2) User's errors or mistakes such as an inappropriate installation or incorrect handling, or an excessively large impact caused by dropping
- 3) Problems caused by devices or equipment other than MIYAWAKI's, or a disallowed use environment
- 4) When a repair or modification has been performed by anyone other than MIYAWAKI or people who are authorized to make such repairs
- 5) Intrusion of salt or other substances that promote significant rust or corrosion or problems from fluids that contain the same substances
- 6) Consumable parts such as Packing, Gasket, O-ring, Diaphragm, etc.
- 7) Attachment or accumulation of foreign matter in the pipe, such as dust and scale
- 8) Problems from fires, natural disasters, or other force majeure which is not MIYAWAKI's responsibility

7.3 Warranty limitation

The remedy available under the warranty shall not exceed the sales price of the products delivered, for any cause whatsoever.

8 SERIAL NUMBER (S. No.) DESIGNATION

The following 4-digit or 9-digit 'S. No.' is displayed on the product.

- For 4-digit display

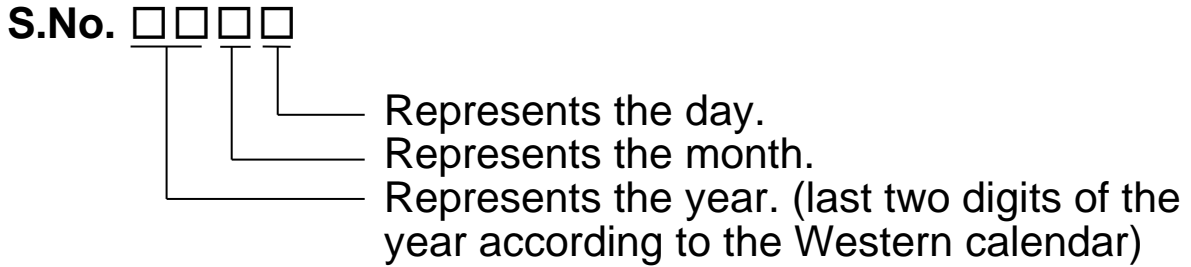

Example of serial number designation

1 7 1 1 → Jan. 1, 2017

2 9 X M → Oct. 21, 2029

- For 9-digit display

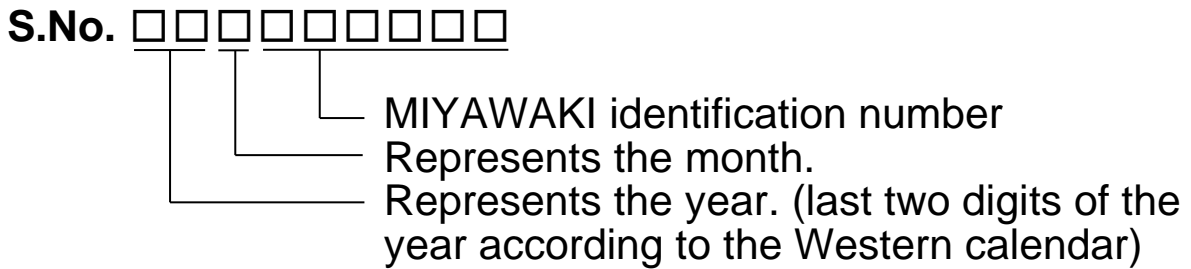

Example of serial number designation

1 7 1 1 2 C 0 2 0 → Jan., 2017

2 9 X 0 5 M 0 5 0 → Oct., 2029

Month designation system

Month	1	2	3	4	5	6	7	8	9	10	11	12
Symbol	1	2	3	4	5	6	7	8	9	X	Y	Z

Day designation system

Day	1	2	3	4	5	6	7	8	9	10	11	12
Symbol	1	2	3	4	5	6	7	8	9	A	B	C

Day	13	14	15	16	17	18	19	20	21	22	23	24
Symbol	D	E	F	G	H	J	K	L	M	N	O	P

Day	25	26	27	28	29	30	31
Symbol	Q	R	S	T	U	V	W

9 GUIDANCE FOR READING SPECIAL PRODUCT NAME

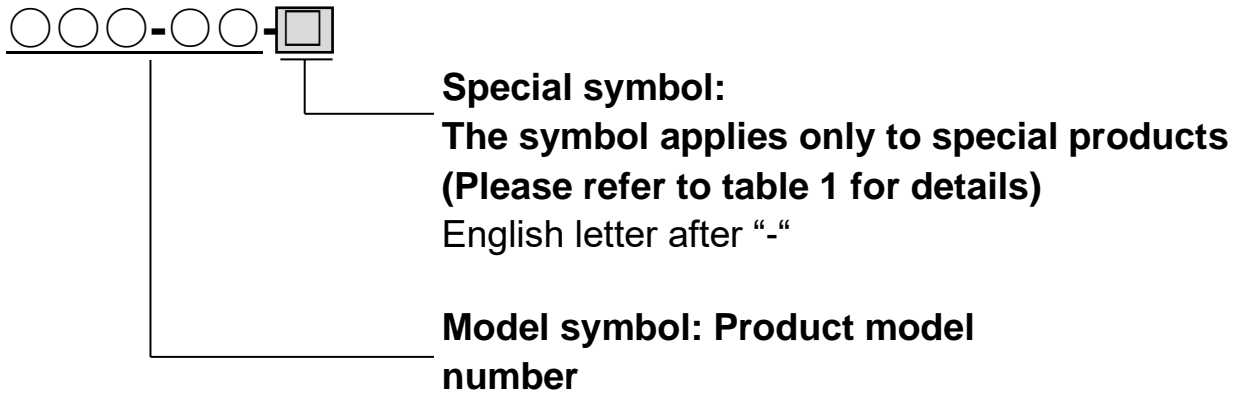

Table 1 Symbol description

Suffix	Special contents
A	Trap for high-pressure gas installed property
C	Blow valve attached
K	Change of gasket
L	Special face to face dimension
M	Change of parts material
P, T	Change of operating pressure, temperature, condensate capacity, etc.
R	Change of screen mesh
V	Change of air vent
X	Other than mentioned above or complex of special contents above

For any questions about the product that you purchased or about the details in this user's manual, please contact the following.

- © 2024 MIYAWAKI INC.

This user's manual may not be reproduced or copied in whole or in part, without the written consent of MIYAWAKI INC.

- Some special specifications of the product you have, may found to be different from the ones in the user's manual. If you have any question, please contact MIYAWAKI, our local authorized agent, or the place where you purchased.
-



If you need any assistance regarding this manual, please contact MIYAWAKI INC.'s International Sales Dept. or its local representative. By scanning QR Code, you can access inquiry form.



INTERNATIONAL SALES DEPT.

2-1-30, Tagawakita, Yodogawa-ku, Osaka, 532-0021, Japan

Tel: +81-6-6302-5549

www.miyawaki-inc.com/en e-mail: export@miyawaki-inc.co.jp

EU Importer and Authorized representative:



Birnbaumsmühle 65, 15234 Frankfurt (Oder), Germany

Tel: +49-335-4007-0097

www.miyawaki.de e-mail: info@miyawaki.de

China Importer and Authorized representative:



Room 902 ,Building 8, Huaqing Chuangzhi Park, No.3 Qingyan Road, Huishan District, Wuxi City
Jiangsu Province China

Tel: +86-510-8359-5125

www.miyawaki-inc.com.cn e-mail: mywkwest@miyawaki-inc.com.cn

808150-00 2409

G3N, G5