

BALL FLOAT STEAM TRAP

# GC1N/GC1V

USER'S MANUAL



 MIYAWAKI INC.

# SAFETY GUIDE

The model GC1N/GC1V ball float steam trap is highly durable and suitable for steam mains that generate relatively small amounts of condensate.

In order to get maximum benefit from this product, be sure to read this manual before installing it.

The following warnings and cautions are shown at appropriate places in this manual.



Failure to observe this type of precaution may lead to serious injury or death.



Failure to follow this type of precaution can lead to injury or damage to equipment and property.

## Table of Contents

---

1	SPECIFICATIONS AND MARKINGS	1
2	CONSTRUCTION DETAILS	2
3	INSTALLATION	3
4	MAINTENANCE	4
5	TROUBLESHOOTING	8
6	WARRANTY	9
7	SERIAL NUMBER(S.No.) DESIGNATION	10
8	GUIDANCE FOR READING SPECIAL PRODUCT NAME	11

# 1 SPECIFICATIONS AND MARKINGS

---



## WARNING

Be sure not to use this product at higher pressures than the specified maximum allowable pressure (PMA) or at temperatures higher than the specified maximum allowable temperature (TMA).

The following items are displayed on the name label or the side of the product.

Check each item to avoid misuse of the product.

- 1) Maximum allowable pressure (PMA): 2.1MPa (305psig)
- 2) Maximum allowable temperature (TMA): 350°C (662°F)
- 3) Maximum differential pressure ( $\Delta$ PMX):  
1.0MPa (145psig), 1.6MPa (230psig), or 2.1MPa (305psig)
- 4) Maximum operating temperature (TMO): 350°C (662°F)
- 5) Size: 15 mm(1/2"), 20mm(3/4"), 25 mm(1")
- 6) Year of production: The two leftmost digits in the four-digit or nine-digit 'S No.' on the name plate are the last two digits of the year of production.
- 7) Flow direction: Shown by an arrow
- 8) Body material: SCS13A
- 9) Model symbol: Showing the product model name

Some pictures and illustrations in this manual are that of the representative model. For more details regarding dimensions and other specifications, please refer to the catalog.

## 2 CONSTRUCTION DETAILS

### GC1N (for horizontal installations)

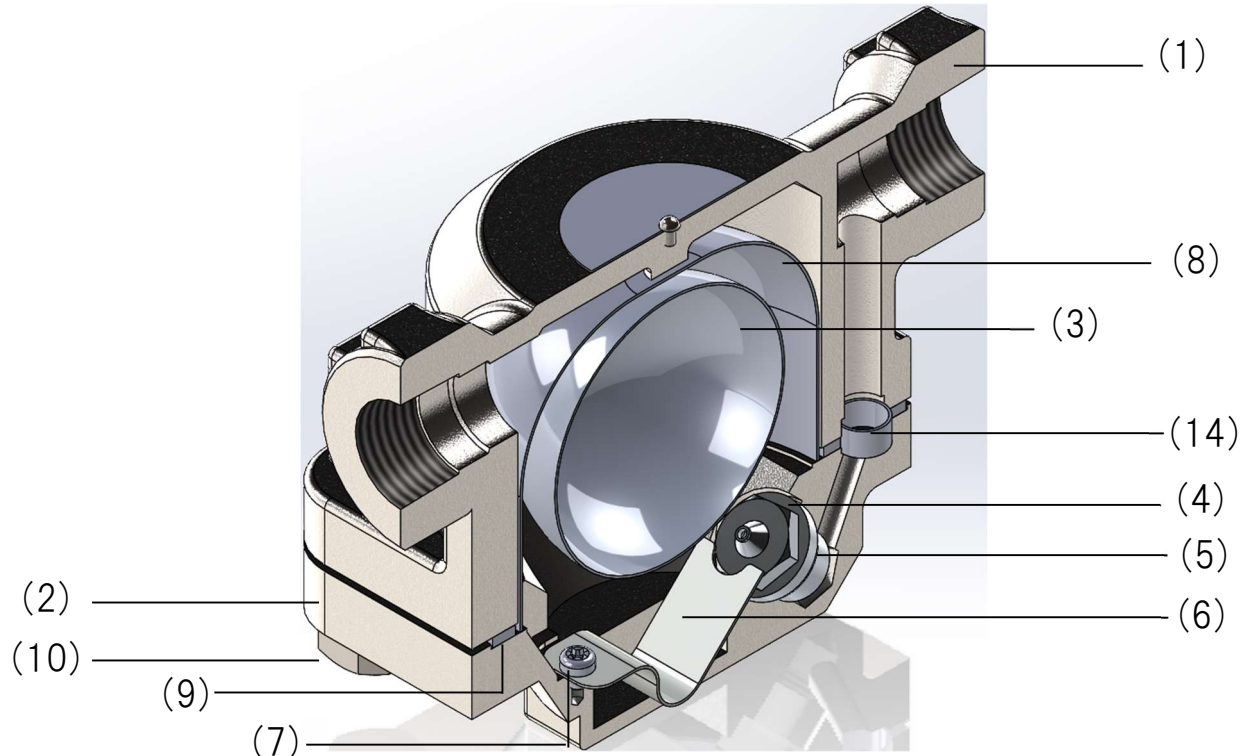

### GC1V (for vertical installations)

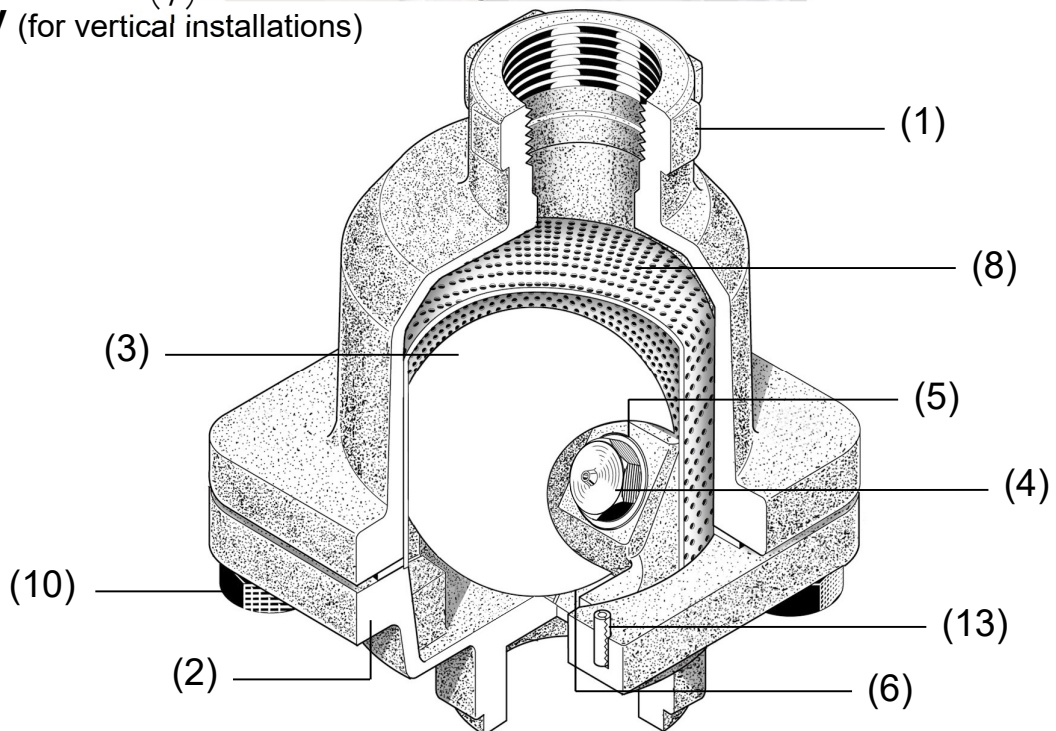

- |                      |                     |                               |
|----------------------|---------------------|-------------------------------|
| 1. Body              | 6. Bimetal          | 11. Name Plate                |
| 2. Bottom Cover      | 7. Screw (Phillips) | 12. Rivet                     |
| 3. Ball Float        | 8. Screen           | 13. Spring Pin<br>(Only GC1V) |
| 4. Valve Seat        | 9. Cover gasket     | 14. Collar<br>(Only GC1N)     |
| 5. Valve Seat Gasket | 10. Bolt            |                               |

### **3 INSTALLATION**

---



#### **WARNING**

**Pay very careful attention when working in hazardous environments. There is a risk of explosion and the possibility of dangerous gases leaking. Always check whether the pipeline contains flammable, high pressure or high temperature materials before starting to work.**

- Make sure that isolation valves are installed on both the upstream and downstream lines.



#### **CAUTION**

**Before installing the product, open both isolation valves and the bypass valve, if one exists, to blow out any debris or dirt inside the pipeline. After blowing out the line, before starting to work, close the isolation valves and allow time for the temperature to drop to a safe working temperature.**

**When installing the product, be sure to leave clearance for maintaining it.**

- 1) Remove the dustproof seals covering both connections.
- 2) Check the flow direction indicated on the name plate or on the side of the body.
- 3) When installing the GC1N, make sure the normal line is on the side, at a right angle to a plum line (basically horizontal).
- 4) When installing the GC1V, make sure to keep the flow direction parallel to a plum line (basically pointing up or down).
- 5) If the installation angle slants more than five degrees away from the angles described above, the operating performance may be reduced.
- 6) Open the isolation valve on the upstream line slowly and make sure the product works normally.

## 4 MAINTENANCE

---



### WARNING

- Before removing the trap from the pipe or disassembling it, be sure to close the isolation valves. Then, release the residual pressure from the trap body (make sure that the pressure in the main body is equal to the atmospheric pressure). After it has fully cooled down (after the temperature of the main body has reached ambient temperature), confirm for safe conditions and then begin work.
- Even when the isolation valves are closed, there may be residual internal pressure due to leaks from the isolation valves. Therefore, be very careful.



### CAUTION

- When replacing parts, make sure the replacement parts are supplied by Miyawaki.

The performance of steam traps deteriorates gradually over time due to wear, corrosion or dirt accumulating around the valve and the valve seat. Please conduct periodic diagnosis of traps in order to keep steam control systems and equipment working well.

### 4.1 Tools for Diagnosis Steam Traps

#### ■ Dr. Trap

It is a diagnostic tool with hardware (diagnostic equipment) that performs automatic diagnosis at high speed (maximum 10 seconds) and exclusive aggregate analysis software from the vibration and temperature information of the trap.

Diagnostic information is recorded in the diagnostic equipment and data can be transferred to the software. As a result, high-speed aggregate analysis, quantitative grasp of steam leakage and loss amount are possible.

#### ■ Dr. Trap Jr.

It is an inexpensive and simple diagnostic tool using hardware (steam trap checker) with vibration sensor, temperature sensor and exclusive aggregate analysis software. From the vibration and temperature information of the trap, the judgment such as good or fail is made by a diagnostician. By inputting the vibration value detected by the steam trap checker to the aggregate analysis software, it is possible to quantitatively grasp the amount of steam leakage and money loss.

**Caution:**

Even if both diagnostic tools are used, accurate diagnosis results may not be obtained depending on the location and installation status of the steam trap, or the type and operating condition of the steam trap.

For details, please contact MIYAWAKI, our local authorized agent, or the place where you purchased.

**4.2 Repairs**

When a trap fails, it is necessary to clean the internal parts and to replace damaged parts. Take the failed trap apart following the steps below.

**4.2.1 Disassembling the trap****4.2.1.1 For disassembling GC1N**

- 1) Remove the four cover bolts (10), and detach the bottom cover (2), while keeping the body (1) facing down.
- 2) Remove the screen (8), the float (3), the collar (14) and the cover gasket (9) in that order.
- 3) Repair the trap according to the instructions in Section 6, "Troubleshooting".

**4.2.1.2 For disassembling GC1V**

- 1) Remove the four cover bolts (10), and detach the bottom cover (2), while keeping the body (1) facing down.
- 2) Remove the screen (8), the float (3) and the cover gasket (9) in that order.
- 3) Repair the trap according to the instructions in Section 6, "Troubleshooting".

**4.2.2 Reassembling the trap****4.2.2.1 For reassembling GC1N**

- 1) Put the cover gasket (9), float (3), screen (8) and collar (14) on the bottom cover (2), and attach them to the body (1). In this case, make sure that the body (1) and the bottom cover (2) are not in opposite directions to each other.
- 2) When putting the body (1) and the bottom cover (2) of the GC1N together, orient the body and cover by aligning the holes for the collar (14) and the bolts (10).
- 3) When fastening the four cover bolts (10), tighten each one the same amount, going around the four bolts several times.
  - Make sure to tighten the bolts in a crosswise pattern, to avoid uneven tightening.
  - The cover gasket (5) must be replaced with a new one each time the trap is taken apart.
  - The valve seat gasket (9) must be replaced with a new one each time the valve seat is detached from the bottom cover (2).

#### 4.2.2.2 For reassembling GC1V

- 1) Put the cover gasket (9), float (3), and screen (8) on the bottom cover (2), and attach them to the body (1). In this case, make sure that the body (1) and the bottom cover (2) are not in opposite directions to each other.
- 2) When putting the body (1) and the bottom cover (2) of the GC1V together, orient the body and cover by inserting the spring pin (13) in the body (1) into the hole on the bottom cover (2).
- 3) When fastening the four cover bolts (10), tighten each one the same amount, going around the four bolts several times.
  - Make sure to tighten the bolts in a crosswise pattern, to avoid uneven tightening.
  - The cover gasket (5) must be replaced with a new one each time the trap is taken apart.
  - The valve seat gasket (9) must be replaced with a new one each time the valve seat is detached from the bottom cover (2).

The torque for each part is shown in the following table.

<b>Parts</b>	<b>Tools</b>	<b>Across the flats</b>	<b>Torque</b>
Valve Seat (4)	Torque wrench	13 mm (0.51")	25N·m
Screw (7)	Torque screwdriver (Standard or Phillips)	-	0.3N·m
Bolt (10) (GC1N)	Torque wrench	17 mm (0.67")	40N·m
Bolt (10) (GC1V)	Torque wrench	17 mm (0.67")	28N·m



## GC1N

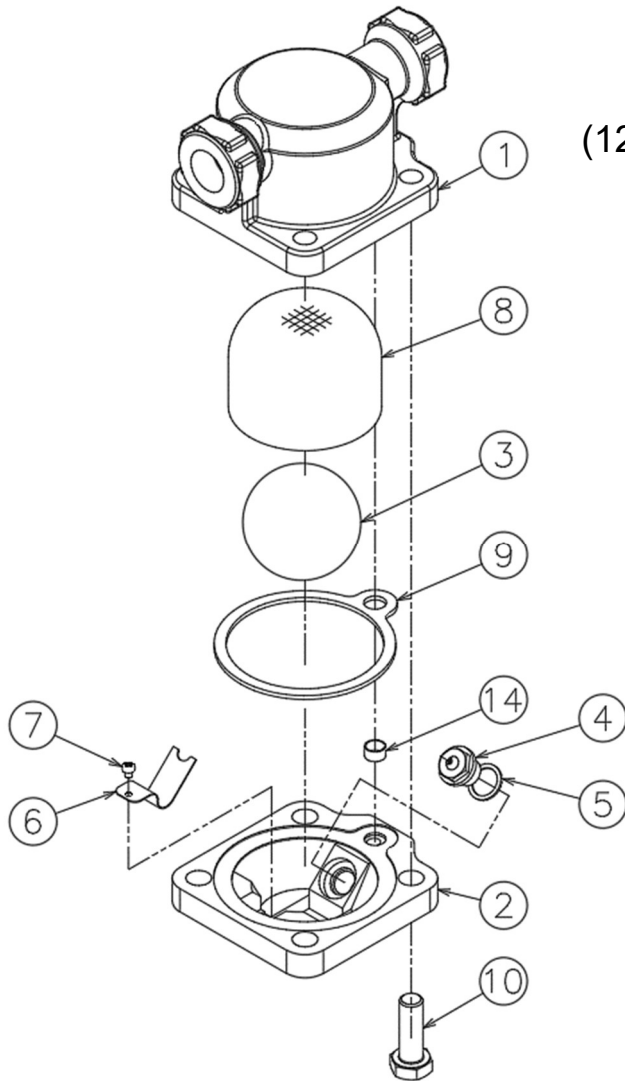

1. Body
2. Bottom Cover
3. Ball Float
4. Valve Seat
5. Valve Seat Gasket
6. Bimetal
7. Screw (Phillips)

## GC1V

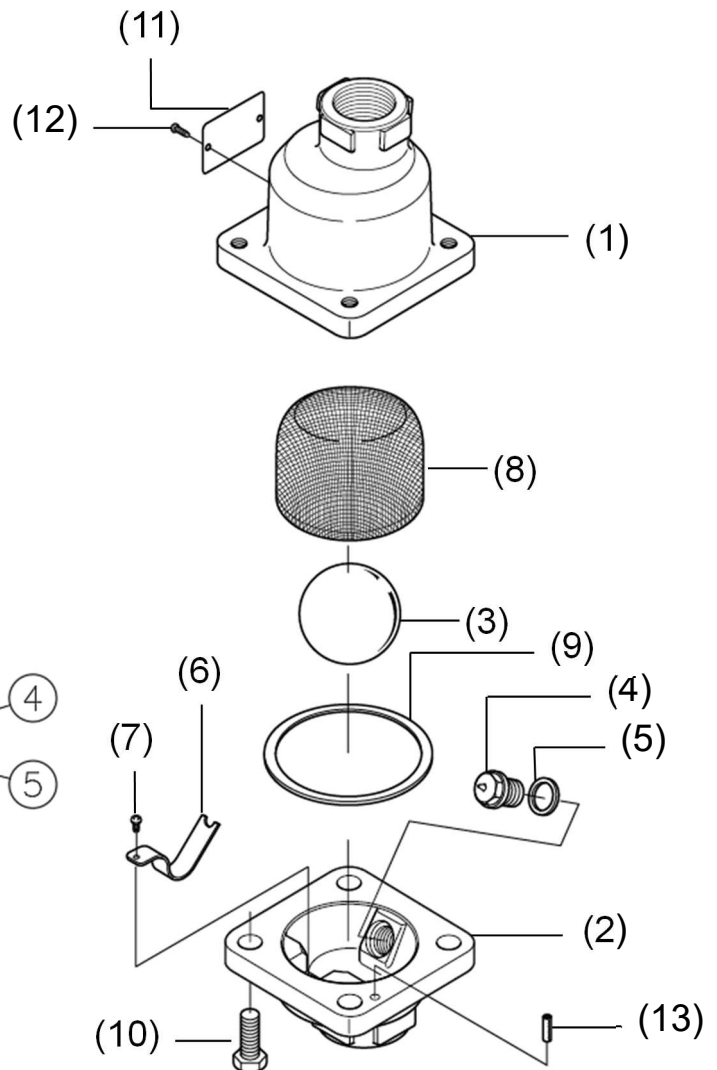

8. Screen
9. Cover Gasket
10. Bolt
11. Name Plate
12. Rivet
13. Spring Pin  
(Only GC1V)
14. Collar  
(Only GC1N)

## 5 TROUBLESHOOTING

Problem	Possible cause	Solution
<b>Air leaks or blows through.</b>	Dirt is stuck around the valve or valve seat.	Clean the valve and the valve seat.
	Damage, erosion or corrosion of the valve seat.	Replace the valve seat.
	The valve seat is loose.	Tighten the valve seat. *1
	The float is damaged.	Replace the float.
	Installation position is wrong.	Change the installation position to Horizontal for GC1N and Vertical for GC1V.
	Wrong installation direction	Make sure the arrow on the main body matches the flow direction of the fluid.
	The bimetal is damaged.	Replace the bimetal.
<b>Air leaks from the body.</b>	The bolts are loose.	Tighten the bolts.*2
	The cover gasket is damaged or worn.	Replace the cover gasket.
	The sealing surface on the body or the bottom cover is damaged.	Replace the body or the bottom cover.
<b>Insufficient condensate discharged, or no condensate discharged.</b>	The screen is clogged.	Clean the screen.
	Dirt has built up on or around the valve seat.	Clean the valve seat.
	The float is damaged.	Replace the float.
	Installation position is wrong.	Change the installation position to Horizontal for GC1N and Vertical for GC1V.
	The bimetal is damaged.	Replace the bimetal.
	The steam pressure was over the specified maximum operating pressure.	Lower the pressure or replace the trap with one that has a higher maximum operating pressure.
	Insufficient condensate capacity	Replace the trap with a larger capacity trap.

\*1 and \*2: Refer to the torque table in Section 4, "Maintenance" to retighten the parts to the correct torque.

## **6 WARRANTY**

---

### **7.1 Warranty period**

The warranty period is 18 months after shipment or 12 months after installation, whichever occurs first.

### **7.2 Details of the warranty**

If the product stops working correctly within the warranty period, we will repair or replace the product free of charge if the cause of the trouble is not one of the following items.

- 1) The precautions described in this manual were not observed.
- 2) User's errors or mistakes such as an inappropriate installation or incorrect handling, or an excessively large impact caused by dropping
- 3) Problems caused by devices or equipment other than ours, or a disallowed use environment
- 4) When a repair or modification has been performed by anyone other than us or people who are authorized to make such repairs
- 5) Intrusion of salt or other substances that promote significant rust or corrosion or problems from fluids that contain the same substances
- 6) Consumable parts such as Packing, Gasket, O-ring, Diaphragm, etc
- 7) Attachment or accumulation of foreign matter in the pipe, such as dust and scale
- 8) Problems from fires, natural disasters, or other force majeure which is not our responsibility

### **7.3 Warranty limitation**

The remedy available under the warranty shall not exceed the sales price of the products delivered, for any cause whatsoever.

## 7 SERIAL NUMBER (S. No.) DESIGNATION

The following 4-digit or 9-digit “S.No.” is displayed on the product.

- For 4-digit display

S.No. □□□□

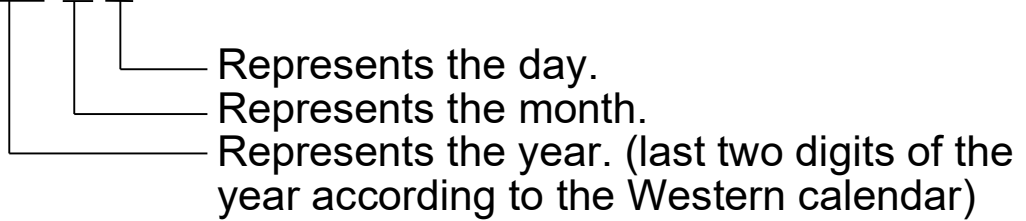

Example of serial number designation

1 7 1 1 → Jan.1, 2017

2 9 X M → Oct. 21, 2029

- For 9-digit display

S.No. □□□□□□□□□

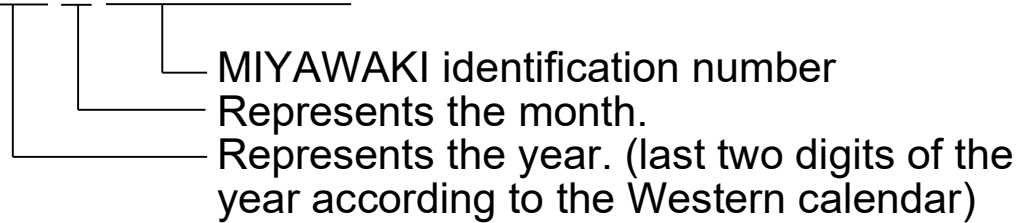

Example of serial number designation

1 7 1 1 2 C 0 2 0 → Jan., 2017

2 9 X 0 5 M 0 5 0 → Oct., 2029

### Month designation system

Month	1	2	3	4	5	6	7	8	9	10	11	12
Symbol	1	2	3	4	5	6	7	8	9	X	Y	Z

### Day designation system

Day	1	2	3	4	5	6	7	8	9	10	11	12
Symbol	1	2	3	4	5	6	7	8	9	A	B	C

Day	13	14	15	16	17	18	19	20	21	22	23	24
Symbol	D	E	F	G	H	J	K	L	M	N	O	P

Day	25	26	27	28	29	30	31
Symbol	Q	R	S	T	U	V	W

## 8 GUIDANCE FOR READING SPECIAL PRODUCT NAME

---

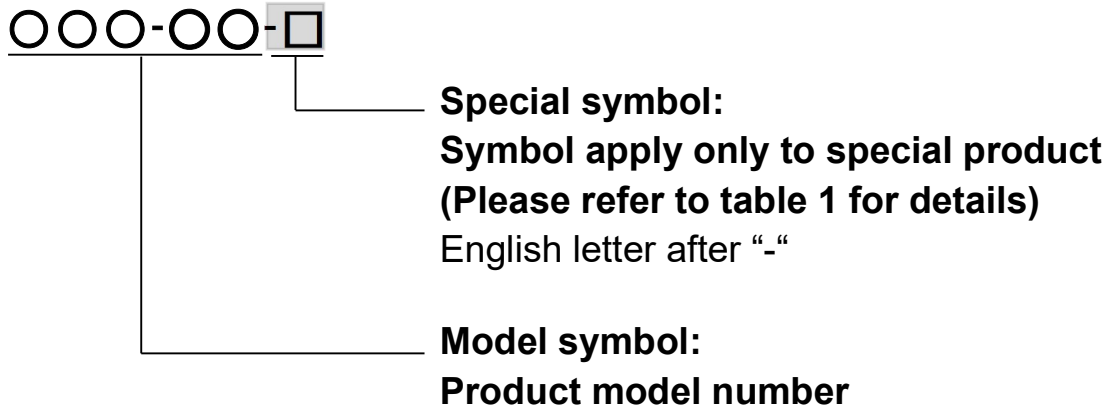

Table 1 Symbol description

Suffix	Special contents
A	Trap for high-pressure gas installed property (only for Gas Trap)
C	Blow valve attached
K	Change of gasket
L	Special face to face dimension
M	Change of parts material
P, T	Change of operating pressure, temperature, condensate capacity, etc
R	Change of screen mesh
V	Change of air vent
X	Other than mentioned above or complex of special contents above

- 
- For any questions about the product that you purchased or about the details in this user's manual, please contact the following.
  - © 2024 MIYAWAKI INC.  
This user's manual may not be reproduced or copied in whole or in part, without the written consent of MIYAWAKI INC.
  - Some special specifications of the product may found to be different from the ones in the user's manual. If you have any question, please contact MIYAWAKI, our local authorized agent, or the company where you purchased the product.
  - In the interest of the development and improvement of our products, MIYAWAKI Inc. reserves the right to change the specification of the products without prior notice.
-



If you need any assistance regarding this manual, please contact MIYAWAKI INC.'s International Sales Dept. or its local representative. By scanning QR Code, you can access inquiry form.



**INTERNATIONAL SALES DEPT.**

2-1-30, Tagawakita, Yodogawa-ku, Osaka, 532-0021, Japan

Tel: +81-6-6302-5549

[www.miyawaki-inc.com/en](http://www.miyawaki-inc.com/en) e-mail: [export@miyawaki-inc.co.jp](mailto:export@miyawaki-inc.co.jp)

EU Importer and Authorized representative:



Birnbaumsmühle 65, 15234 Frankfurt (Oder), Germany

Tel: +49-335-4007-0097

[www.miyawaki.de](http://www.miyawaki.de) e-mail: [info@miyawaki.de](mailto:info@miyawaki.de)

China Importer and Authorized representative:



Room 902, Building 8, Huaqing Chuangzhi Park, No.3 Qingyan Road, Huishan District, Wuxi City Jiangsu Province, China

Tel: +86-510-8359-5125

[www.miyawaki-inc.com.cn](http://www.miyawaki-inc.com.cn) e-mail: [mywkwest@miyawaki-inc.com.cn](mailto:mywkwest@miyawaki-inc.com.cn)

808145-00 2404  
**GC1N/GC1V**