

About MIYAWAKI

Over 85 years Experience, Technology and Quality



The company MIYAWAKI has over 85 years history as one of the leading Japanese manufacturers of equipment for steam and condensate lines.

MIYAWAKI has a long experience as the leading supplier of steam traps for oil refineries and chemical plants in Japan. Besides of steam traps the company offers a wide range of pressure reducing valves for steam and other media, steam-water-mixing valves, separators, strainer, sight glasses and other ancillary equipment.

MIYAWAKI offers sophisticated hardware and software solutions for managing the steam trap population in a plant.

As the world leader of the production of bimetallic temperature control steam traps, the most effective steam traps for steam tracing and steam main lines in the sense of energy conservation, MIYAWAKI contributes substantially to the reduction of CO₂ emissions and to the development of a healthy environment.

Our mission



Kensuke Miyawaki,
President, member
of the executive board
of MIYAWAKI Inc.

"MIYAWAKI's mission is to promote the ideas of energy saving and environmental protection, to fulfil the deliveries of its products with a high rate of reliability and to provide a high level of technical support for our products.

Reducing the consumption of energy in the form of steam is an extremely important goal of each modern industrial enterprise. Steam Traps are able to play an important role in this process, because by improving the management of the steam and condensate system and by regular professional steam trap surveys, up to 40% of the steam losses can be reduced which are not caused by the manufacturing process.

We have every confidence that the high quality of MIYAWAKI products will enable our customers to save energy and to meet their production goals."

Our history

MIYAWAKI opened its doors in 1933 and began designing steam traps for industrial use. In 1949, after extensive experiments and tests, MIYAWAKI developed an entirely new type of steam trap, with a "Duplex"-type valve, a double-ported valve operating by the pressure differential to increase the condensate capacity.

In the following years, the design was further refined and sales soared to the point where by 1953 the company MIYAWAKI Steam Trap Manufacturing Co., Ltd. was able to incorporate. Along with the development and sales of products other than steam traps, the name changed to MIYAWAKI Inc. in April 1986.

To emphasize the growing international activities of MIYAWAKI Inc., in June 1991 the subsidiary company MIYAWAKI GmbH was established in Germany. Later a joint venture in Russia had been opened. In April 2018, the subsidiary company MIYAWAKI WEST Co., Ltd was established in China. During the last decade the network of sales representatives around the world was enlarged considerably.



MIYAWAKI certificates	4
Pressure Equipment Directive 2014/68/EU	5
Steam Trap Selection Guide	6

Steam Traps

Temperature Control Trap	7 – 14
Thermostatic Radiator Trap	15 – 16
Balanced Pressure Thermostatic Trap	17 – 20
Thermodynamic Disc Trap	21 – 28
Inverted Bucket Trap	29 – 35
Ball Float Trap	37 – 52
Steam Trap with Two-bolt connection	53 – 54
Pumping Trap	55 – 60

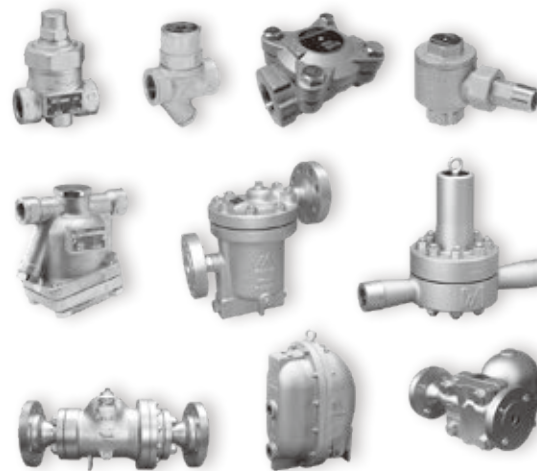

Air Traps

Air Trap	61 – 67
----------	---------



Air Vents

Air Vent	69 – 72
----------	---------



Pressure Reducing Valves

Pressure Reducing Valve	73 – 82
-------------------------	---------



Hot Water Supplying System

Steam-Water-Mixing Valve, Water Gun	83 – 85
-------------------------------------	---------



Ancillary Equipment

Check Valve, Blow-down Valve	86
Strainer, Vacuum Breaker, Anti-Freezing Valve	87
Sight Glass	88
Separator	89



Testing Equipment

Steam Trap Survey Assistant	90 – 91
Steam Trap Management System	92 – 93



MIYAWAKI-Technology

SCCV®-System	94 – 95
--------------	---------

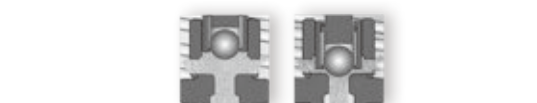

International Comparison and Conversion

Material Standards and Temperature, Flange Standards	96 – 97
Pressure, Steam Pressure Table	98 – 99

English Edition 2022
No. PG-07_2209E

In the interest of the development and improvement of our products, MIYAWAKI Inc. reserves the right to change the specification of the products.

© MIYAWAKI Inc.

Quality, Performance and Challenges to energy saving

Since 1933, MIYAWAKI has committed itself to a policy of **uncompromising quality, performance and challenges to energy conservation.**

Research and development has a high priority at MIYAWAKI. To meet industry's demands and to ensure quality, MIYAWAKI invests heavily in the best personnel, facilities, manufacturing techniques and quality control systems available today.

This policy of „**Technology First**“ has resulted in major advances in steam trap design and operation.

As a result of the certification MIYAWAKI can assure all our customers of its continuing policy of high quality standards and of the fact that all products are manufactured in accordance with international regulations and technical requirements.

ISO 9001



ISO 14001



European Directive 2014/68/EU



Certificate of Conformity Russia



Pressure Equipment Directive 2014/68/EU of the European Parliament and of the Council



In the course of the harmonization of the laws of the EU Member States concerning pressure equipment, the Pressure Equipment Directive 97/23/EC (PED) had been adopted in May 1997. The Directive came into effect on 30 May 2002. Considering the experience and changes during the implementation of the Directive 97/23/EC, the European Union published on June 27, 2014 the new Pressure Equipment Directive 2014/68/EU. The new Directive entered into force on July 19, 2016.

According to the PED all manufacturers of pressure equipment covered by the PED, are under the obligation to subject each item of equipment to one of the conformity assessment procedures described in the PED. The conformity assessment procedures to be applied to an item of pressure equipment with a view to

affixing the CE marking shall be determined by the category, in which the equipment is classified. In this connection it is necessary to take into consideration the statement of the PED, that pressure equipment which is subject to Article 4, Section 3 of the PED "...shall be designed and manufactured in accordance with the sound engineering practice of a Member State in order to ensure safe use. ... Such equipment ... shall not bear the CE marking referred to in Article 18" of the PED.

In cooperation with TÜV Rheinland Industrie Service GmbH MIYAWAKI Inc., Osaka, Japan examined all products with respect to the PED and certified its production process in accordance with Modul A2 of the PED (internal manufacturing checks with monitoring of the final assessment).

As a result of this certification process MIYAWAKI Inc. draws the following conclusions:

1. The following MIYAWAKI products are classified according to Article 4, Section 3 of the PED which does not allow to bear the CE marking:

Steam Traps:

TB1N, TBU4, TB7N, TB9N, TB51, TB52, TBH71, TBH72, TBH81, TBH82, W, DC1, DC2, DV1, DL1, DX1, DF1, S31N, SC31, SC, SF, SV, SL, SU2N, SU2H, SD1, S55N, S55H, S61N, S62N, ER105, ER110, ER116, ES5, ESU5, ES8N, ES10, ES12N, ESH8N, G11N, G12N, G3N-10R (to DN65), G3N-16R (to DN50), G2, GC1, GC20, G20N, G30

Steam Pressure Reducing Valves: RE1, RE2, RE3, REC1, RE10N

Steam-Water-Mixing Valve: MX1N

All above MIYAWAKI products are designed and manufactured in accordance with the sound engineering practice as requested by the PED.

2. Steam traps not included into point 1 belong to category I or category II according to Annex II & III of the PED. They will bear the CE marking and the conformity with the PED will be confirmed by issuing a declaration of conformity.



As a result of the certification by TÜV Rheinland Industrie Service GmbH MIYAWAKI can assure all our customers of its continuing policy of high quality standards and of the fact, that all products are manufactured in accordance with the regulations and technical requirements of the EU.

		First Choice	Second Choice
Steam Mains	< 1,6 MPa	TB9N	GC1, D, S, ES
	< 2,1 MPa	TB7N	GC1, S
	< 6,4 MPa	TB51, TB52	S61N, S62N, ESH
	< 20,0 MPa	TBH71, 72, 81, 82	
Process Equipment	Heater	G, ES, ER	S
	Heat Exchanger	G	ES, ER
	Vaporizer	G	ES, S
	Distiller	D	ES, S
	Sterilizer	D	ES, G, S
	Cylinder Dryer	ES, ER	
	Band Dryer	G	ES, ER, D
	Multi-Platen Presses	G	ES, D, S
	Vulcanizer	D	S, ES
	Tyre Presses	D	S, ES
Autoclaves	D	G, ES	
Laundry Equipment	Dryer	G	ES, D, S
	Tumbler	ES, ER	D, S
	Presses	D	S, ES
	Steam Mannequins	D	ES, S
	Steam Iron	SL3	SD1
	Steam Mangles	D, G	ES, S
Food Processing Equipment	Process Boiling Pans	G	ES, D
	Hot Tables	D, G	ES
	Jacketed Boiling Pans	D	G, ES, S
	Tilting Pans	ES	D
	Brewing Pans	G	ES, D
	Evaporator	G	ES, ER
	Retorts	G	ES, ER
Heating & Air Conditioning	Steam Radiator	W	D
	Unit Heaters	G	ES
	Convectors	W	D, ES
	Radiant Panels	W	D, ES
	Air Heater	D	ES, G
	Air Humidifiers	ES, G	D, S
	Heating Coils	D, ES	G, S
	Air Conditioning Units	ES, G	D
	Calorifiers	G, ES	D
Tracing	Steam Tracer Lines	TB	D
	Tank Heating	TB	D, ES, S
	Copper Tracing (Instrument Tracing)	TB1N	DC1

Disclaimer: This Guide is offered as a recommendation guide only and is not intended to replace the selection by a qualified person.

Temperature Control Steam Traps

SERIES TB

Temperature Control Steam Traps are bimetallic steam traps which do not follow the steam saturation curve. The discharge temperature can be adjusted manually, what allows to adopt these steam traps to a wide range of applications, where optional undercooling is possible and where sensible heat savings and flash steam reduction are desirable. These steam traps are perfectly fitted for reducing the steam consumption at steam main and steam tracing lines thus guaranteeing a high degree of energy savings.

Models TB7N & TB9N	with forged steel body for low and medium pressure applications
TBU4, TBU4B	with stainless steel body for low pressure tracing
TB1N	with steel body for low pressure applications
TB51/52	with forged steel body for high pressure applications
TBH71/72/81/82	with cast steel body for high pressure applications

Features

- All traps are equipped with the patented valve mechanism SCCV®-System (see pages 90 – 91).
- The SCCV®-System ensures a superior closing performance in the center of the port, greatly reduced wear of the internal parts and extended lifetime of the trap.
- Highly efficient in energy conservation – eliminates virtually 100% of steam loss.
- Continuous discharge of the condensate according to the adjusted temperature – not influenced by inlet pressure changes.
- Inline repairable – easy and quick replacement of the bimetal unit and the seat.
- Readjustment possible while the trap is in operation (for low pressure applications).
- All traps equipped with integral strainer.
- Can be installed both horizontally and vertically.

Suitable for:

TB7N	Steam main lines and tracing lines
TB9N	Steam main lines, tracing and small heat exchanger applications with specific condensate undercooling
TBU4, TB1N	Steam tracing lines
TB51/52	High pressure steam main lines
TBH71/72/81/82	High pressure steam main lines

Operating principle

 cold condensate  hot condensate

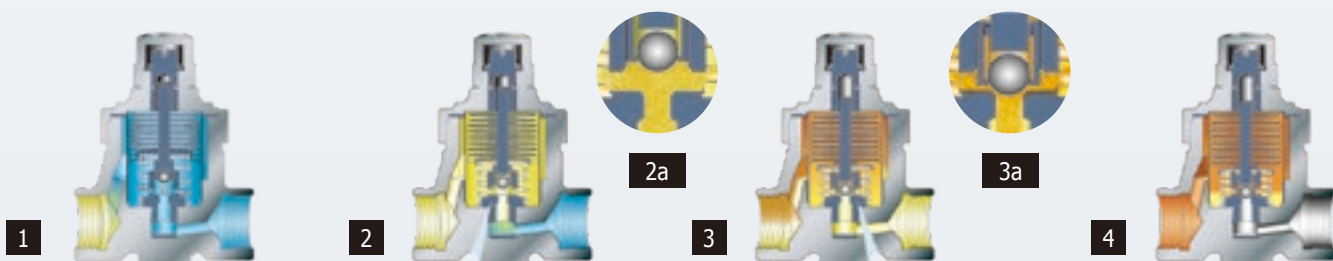

1) On start-up, the bimetal discs are all flat and the valve shaft is up with the valve fully open. Virtually all cold condensate and air are discharged.

2) As the temperature of the condensate increases, the bimetal discs begin to curve gradually and force the valve shaft and the valve holder to move down.

2a) Most of the condensate is still discharged quickly, since the valve and the holes in the fixed guide on the valve seat are still fully open.

3) When condensate with higher temperature (near to set temperature) flows in, the bimetal discs are curved even more and at the same time the valve shaft moves down and the valve holder closes the holes in the guide partially.

3a) The amount of condensate being discharged is reduced quickly. This prolongs the time that the hot condensate stays near the bimetal discs and the heat of the condensate is transferred to the bimetal discs much more effectively.

4) In case of very low condensate flow, the holes in the guide are closed completely by the valve holder and the valve will close precisely in the center of the seat. Normally, the trap is filled with hot condensate and the operation will rest in the state shown in figure 3. Condensate will be discharged continuously at a stable temperature (very close to the set temperature).

TB7N

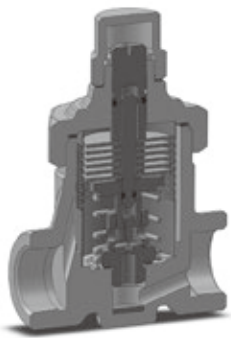

Available options TB7N

- with ball valve (TB7BN-C)
- with blow valve (TB7BN-R)
- with scale removal (TB7N-SR)

Special version TB7N-P

with maximum operating pressure 2,7 MPa / 392 psig

Special face-to-face dimensions available.

* **Curve 1** shows the trap's maximum capacity when discharging cold condensate.

** **Curve 2** shows the trap's maximum capacity when discharging hot condensate at a temperature of 10°C (18°F) below the adjusted temperature of the trap.

Standard factory setting*:

100°C at 1,0 MPa (212°F at 145 psig)

* Settings may differ in various regions.

For more information please contact us.

Max. allowable pressure (PMA) = 4,0 MPa (580 psig)

Max. allowable temperature (TMA) = 400°C (752°F)

Dimensions

TB7N / TB7NW

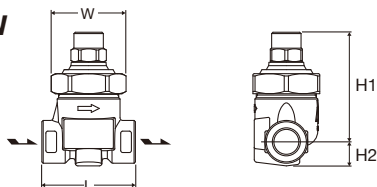

TB7NF

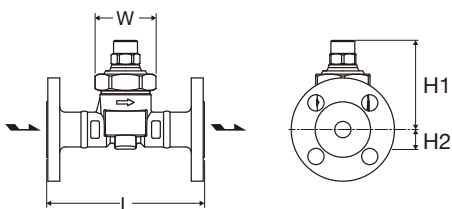

Capacity Chart TB7N

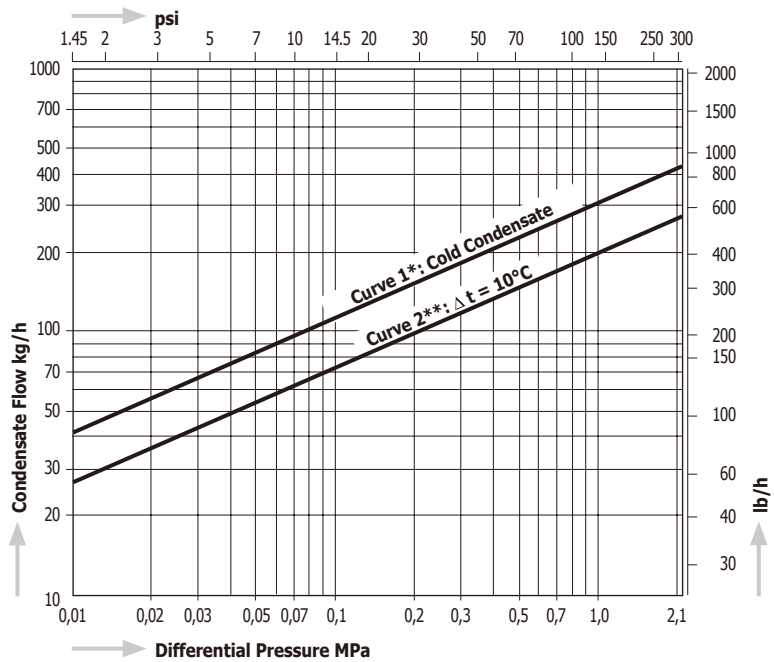

Temperature Stroke Chart TB7N

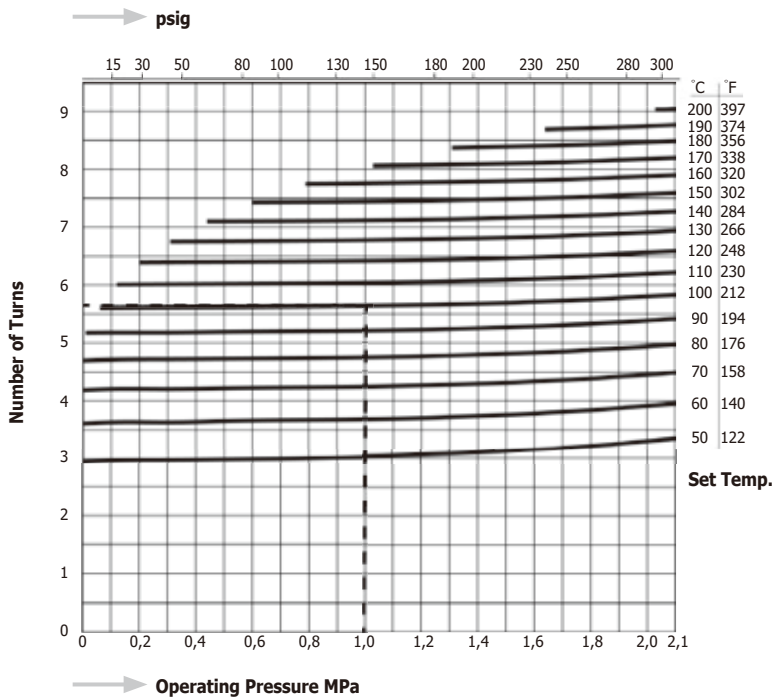

Model	Connections	Size	Max. Operating Pressure		Max. Operating Temperature		Adjustable Range		Dimensions (mm)				Dimensions (in)				Body Material	Weight						
			MPa	psig	°C	°F	°C	°F	L	H1	H2	W	L	H1	H2	W		kg	lb					
TB7N	Screwed Rc, NPT	1/2"	2,1	305	350	662	50 - 200	122 - 392	70	18	56	2.8	3.2	0.7	2.2	Forged Steel A105	0,9	2.0						
		3/4"							82			19		3.1			0.8	1,0	2.2					
		1"							80			23		3.1			0.9	1,1	2.4					
TB7NW	Socket Weld JIS, ASME, DIN	1/2"	2,1	305	350	662	50 - 200	122 - 392	70	18	56	2.8	3.2	0.7	2.2	Forged Steel A105	2,0-2,6 *1	4.4-5.7 *1						
		3/4"							82			19		3.1			0.8	1,0	2.2					
		1"							80			23		3.1			0.9	1,1	2.4					
TB7NF	Flanged JIS, ASME	1/2"	2,1	305	350	662	50 - 200	122 - 392	145	82	18	56	5.7	3.2	2.2	Forged Steel A105	2,5-3,4 *1	5.5-7.5 *1						
		3/4"							150								19	5.9	3.2	0.7	2.2	2,6	5.7	
		1"							160								23	6.3	3.2	0.7	2.2	3,4	7.5	
	Flanged DIN PN40	DN15	2,1	305	350	662	50 - 200	122 - 392	150	82	18	56	5.9	3.2	0.7	2.2	Forged Steel A105	3,4	7.5					
		DN20							160									23	6.3	3.2	0.7	2.2	4,0	8.8
		DN25							160									23	6.3	3.2	0.7	2.2	4,0	8.8

*1 Depending on size and flange standard the weight of the traps differs. Please, look at our technical drawings.

Stainless Steel as body material is available as special design. For more details, please contact MIYAWAKI Inc. or an authorized representative.

TB9N

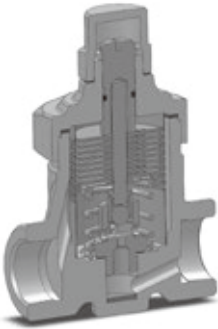

Screwed & Socket Weld

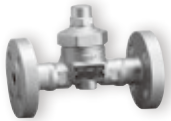

Flanged Connection



with Ball Valve



with Blow Valve



with Scale Removal

Available options TB9N

- with a ball valve (TB9BN-C)
- with a blow valve (TB9BN-R)
- with scale removal (TB9N-SR)

Special face-to-face dimensions available.

* **Curve 1** shows the trap's maximum capacity when discharging cold condensate.

** **Curve 2** shows the trap's maximum capacity when discharging hot condensate at a temperature of 10°C (18°F) below the adjusted temperature of the trap.

The dashed line shows the standard factory setting:

100°C at 0,5 MPa (212°F at 73 psig)

Max. allowable pressure (PMA):
4,0 MPa (580 psig)

Max. allowable temperature (TMA):
400°C (752°F)

Dimensions

TB9N / TB9NW

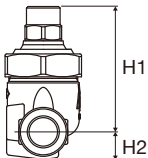
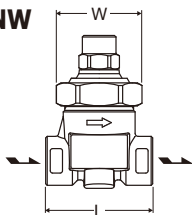

TB9NF

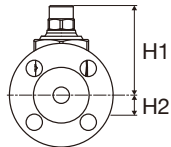
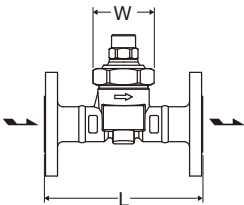

Capacity Chart TB9N

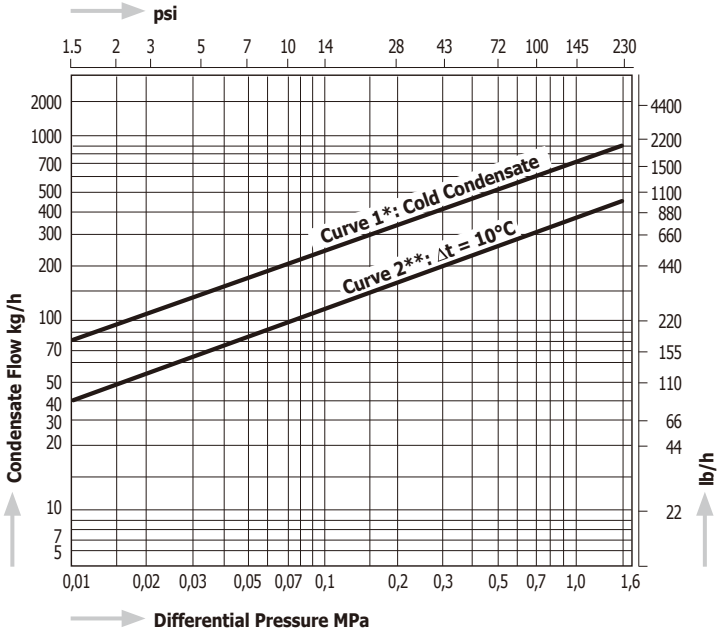

Temperature Stroke Chart TB9N

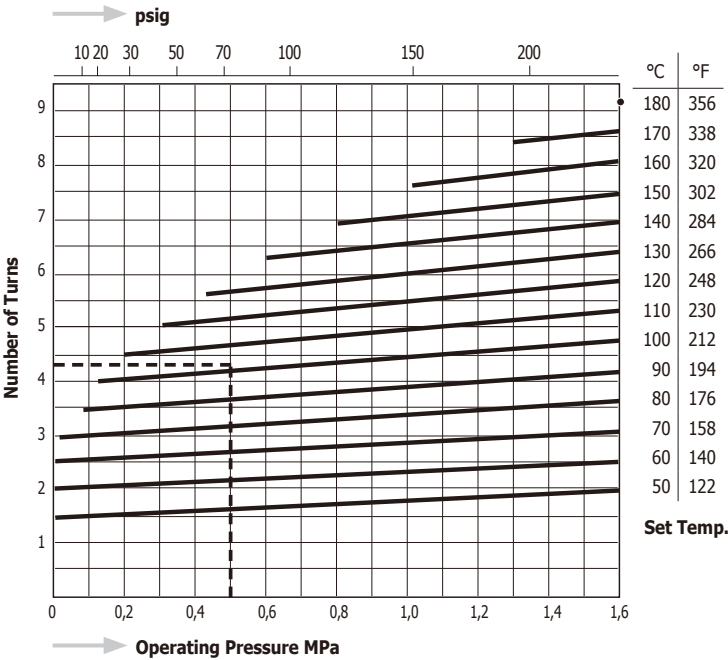

Model	Connections	Size	Max. Operating Pressure		Max. Operating Temperature		Adjustable Range		Dimensions (mm)				Dimensions (in)				Body Material	Weight		
			MPa	psig	°C	°F	°C	°F	L	H1	H2	W	L	H1	H2	W		kg	lb	
TB9N	Screwed Rc, NPT	1/2"	1,6	230	350	662	50 - 180	122 - 356	70	18	56	2,8	3,2	0,7	2,2	Forged Steel A105	0,9	2,0		
		3/4"							80			19					3,1	1,0	2,2	
		1"							80			23					3,1	1,1	2,4	
TB9NW	Socket Weld JIS, ASME, DIN	1/2"	1,6	230	350	662	50 - 180	122 - 356	70	18	56	2,8	3,2	0,7	2,2	Forged Steel A105	0,9	2,0		
		3/4"							80			19					3,1	1,0	2,2	
		1"							80			23					3,1	1,1	2,4	
TB9NF	Flanged JIS, ASME	1/2"	1,6	230	350	662	50 - 180	122 - 356	145	82	56	5,7	3,2	0,8	2,2	Forged Steel A105	2,0-2,5 *1	4,4-5,5 *1		
		3/4"							150			18					5,9	2,6	5,7	
		1"							150			23					6,3	3,4	7,5	
	Flanged DIN PN40	DN15	1,6	230	350	662	50 - 180	122 - 356	150	82	18	56	5,9	3,2	0,7	2,2	Forged Steel A105	2,6	5,7	
		DN20							160				18					6,3	3,4	7,5
		DN25							160				18					6,3	4,0	8,8

*1 Depending on size and flange standard the weight of the traps differs. Please, look at our technical drawings.

Stainless Steel as body material is available as special design. For more details, please contact MIYAWAKI Inc. or an authorized representative.

TBU4, TBU4B

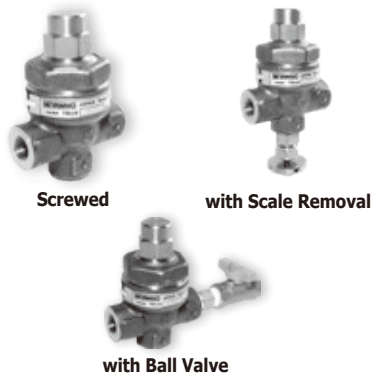
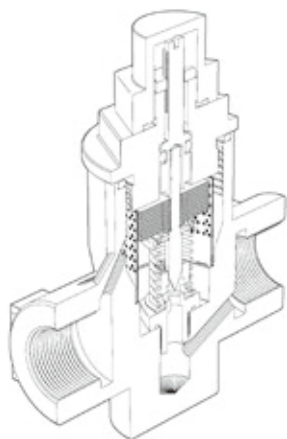

Available options TBU4

with a ball valve (TBU4B-C)
with scale removal (TBU4-SR)

Special version TBU4-10

Operating pressure range:

0,5 – 1 MPa (73 – 145 psig)

* **Curve 1** shows the trap's maximum capacity when discharging cold condensate.

** **Curve 2** shows the trap's maximum capacity when discharging hot condensate at a temperature of 10°C (18°F) (TBU4) / 5°C (9°F) (TB1N) below the adjusted temperature of the trap.

Standard factory setting:

70°C at 0,5 MPa; 158°F at 73 psig

The dashed line

shows the standard factory setting.

Dimensions

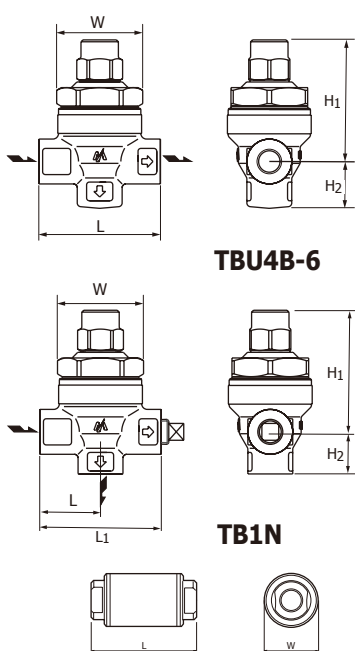

Capacity Chart TBU4/TBU4B-6

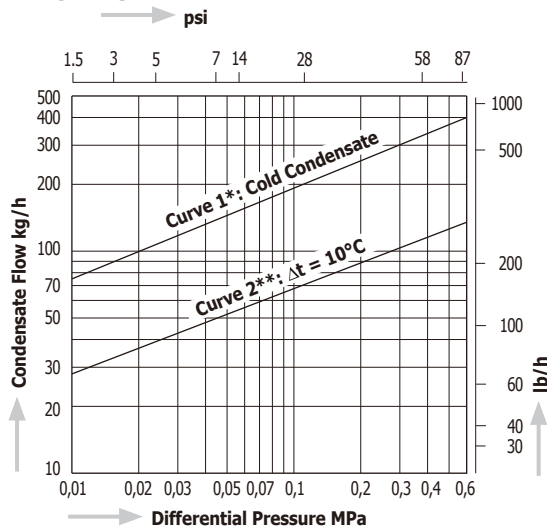

TB1N

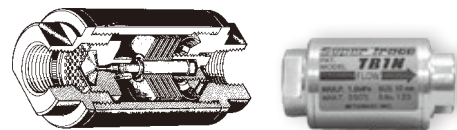

Capacity Chart TB1N

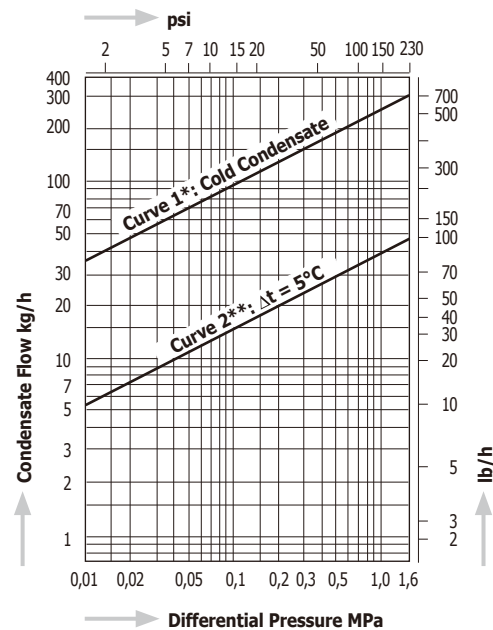

Temperature Stroke Chart TBU4/TBU4B-6

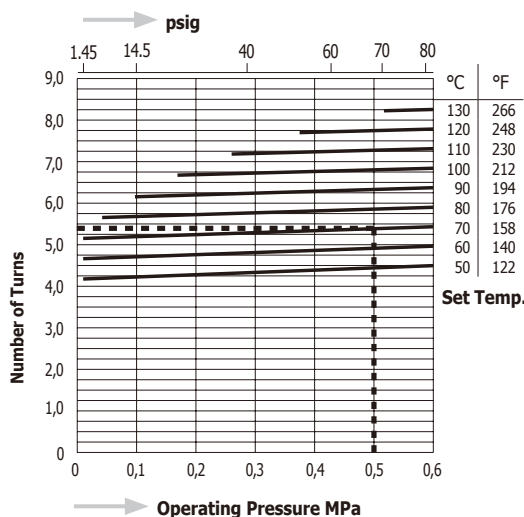

Temperature Stroke Chart TB1N

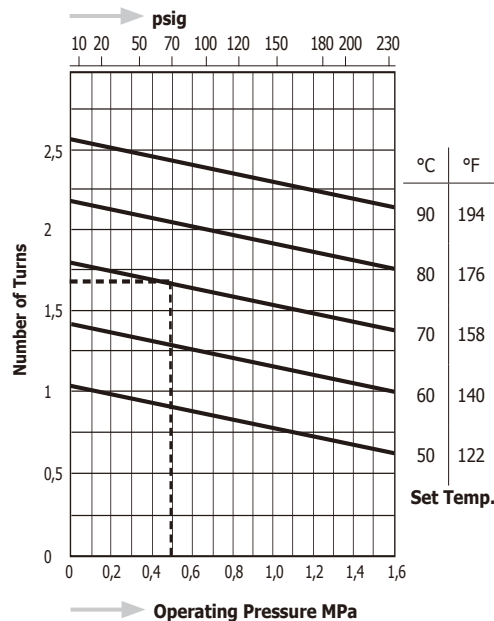

Model	Connections	Size	Max. Operating Pressure		Max. Operating Temperature		Adjustable Range		Dimensions (mm)					Dimensions (in)					Body Material	Weight	
			MPa	psig	°C	°F	°C	°F	L	L ₁	H ₁	H ₂	W	L	L ₁	H ₁	H ₂	W		kg	lb
TBU4-6	Screwed Rc, NPT	¼", 3/8"	0,6	87	220	428	50 – 130	122 – 266	65	–	25	–	2,6	–	1,0	–	–	–	Stainless Steel SUS F304	0,58	1,28
TBU4B-6									32,5	65	22,5	46	1,3	2,6	0,9	2,6	0,9				
TB1N	Screwed Rc, NPT	¼", 3/8"	1,6	230	350	662	50 – 90	122 – 194	70	–	–	–	38	2,8	–	–	–	1,5	Carbon Steel S25C	0,35	0,77

TB51, TB52

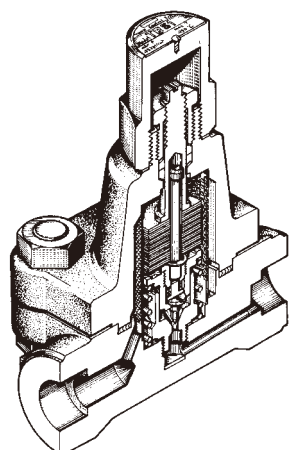

Screwed & Socket Weld

Flanged

Special face-to-face dimensions available.

* **Curve 1** shows the trap's maximum capacity when discharging cold condensate.

** **Curve 2** shows the trap's maximum capacity when discharging hot condensate at a temperature of 10°C (18°F) below the adjusted temperature of the trap.

Standard factory setting:

TB51-45, TB52-45:
180°C at 2,1 MPa; 356°F at 305 psig
TB51-65, TB52-65:
220°C at 4,4 MPa; 428°F at 638 psig

The dashed line

shows the standard factory setting.

Dimensions

TB51, TB52, TB51W, TB52W

TB51F, TB52F

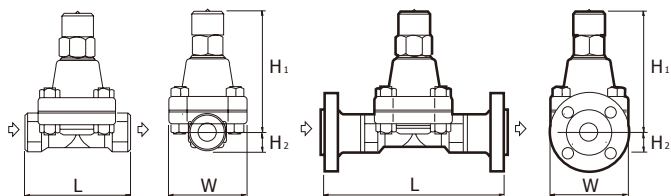

Capacity Chart TB51/52-45

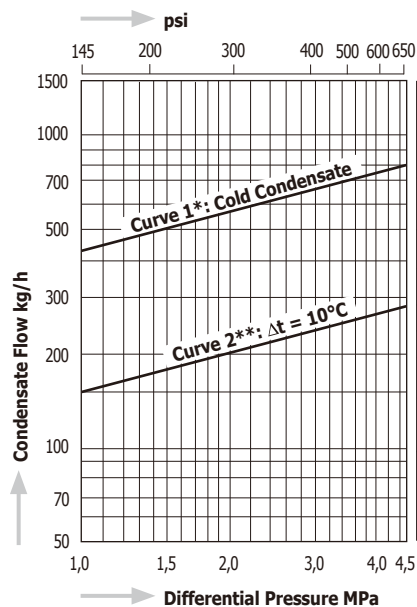

Temperature Stroke Chart TB51/52-45

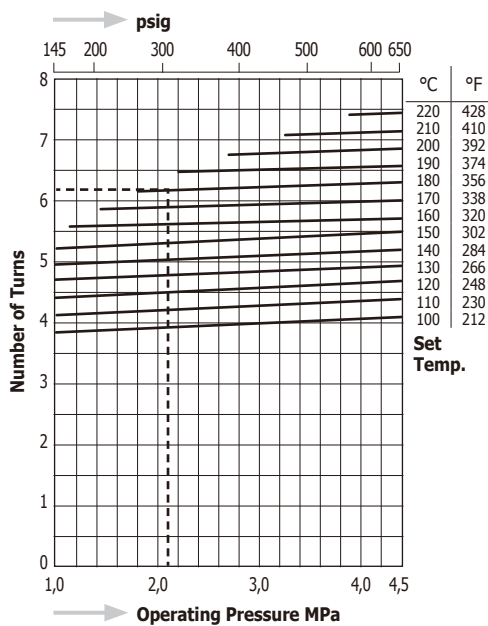

Capacity Chart TB51/52-65

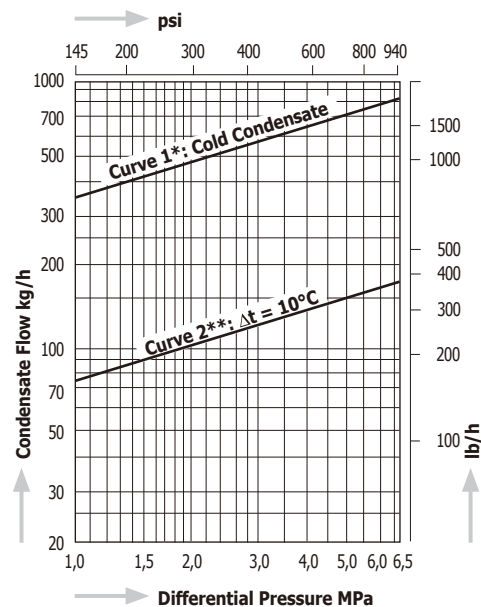

Temperature Stroke Chart TB51/52-65

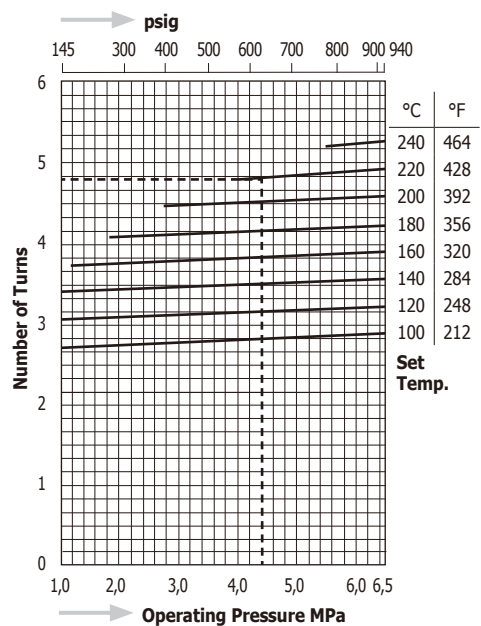
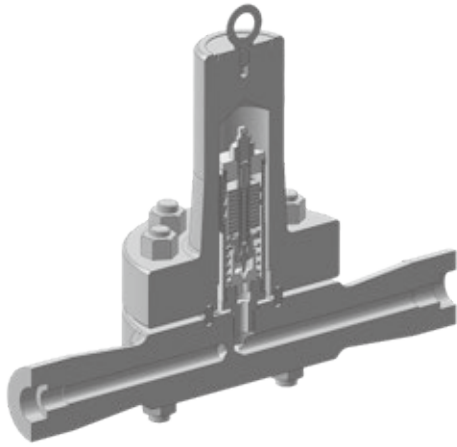

Table 1: Face-to-face dimensions / weights

Model	Size (in)	ASME 600 lb				DIN PN63 / PN100				JIS 63 K / ASME 900 lb			
		mm	in	kg	lb	mm	in	kg	lb	mm	in	kg	lb
TB51F TB52F	1/2"	200	7.9	7,3	16.1	210	8.3	9,4	20.7	220	8.7	9,6	21.2
	3/4"	210	8.3	8,5	18.7	230	9.1	11,4	25.1	230	9.1	11,1	24.5
	1"	240	9.4	9,6	21.2	230	9.1	12,5	27.6	240	9.4	12,1	26.7

Model	Connections	Size	Max. Operating Pressure		Max. Operating Temperature		Adjustable Range		Dimensions (mm)				Dimensions (in)				Body Material	Weight			
			MPa	psig	°C	°F	°C	°F	L	H1	H2	W	L	H1	H2	W		kg	lb		
TB51 (TB52)	45 65	Screwed Rc, NPT	1/2" - 1"	4,5	653	425	800	100 - 220	212 - 428	130	155	25	100	5.1	6.1	1.0	3.9	Forged Steel A105	5,7	12,6	
				6,5	943	(475)	(887)	100 - 240	212 - 464										5,7	12,6	
TB51 (TB52)W	45 65	Socket Weld JIS, ASME, DIN	1/2" - 1"	4,5	653	425	800	100 - 220	212 - 428	130	155	25	100	5.1	6.1	1.0	3.9		TB52: A182 F22	5,7	12,6
				6,5	943	(475)	(887)	100 - 240	212 - 464											5,7	12,6
TB51 (TB52)F	45 65	Flanged JIS, ASME, DIN	1/2" - 1"	4,5	653	425	800	100 - 220	212 - 428	Table 1	155	25	100	Table 1	6.1	1.0	3.9	Table 1	Table 1	Table 1	
				6,5	943	(475)	(887)	100 - 240	212 - 464										Table 1	Table 1	

TBH71, TBH72 TBH81, TBH82



TBH72, TBH81, TBH82
Socket Weld



TBH71
Flanged

Dimensions

TBH71- ...W
Socket Weld

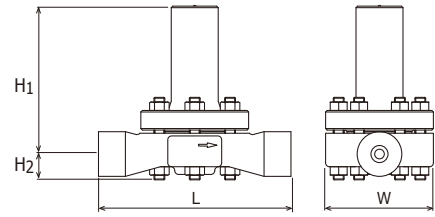

TBH71- ...F
Flanged

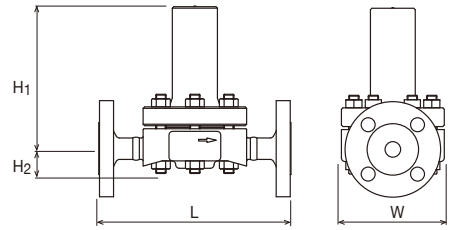

TBH72- ...W, TBH81- ...W, TBH82- ...W
Socket Weld

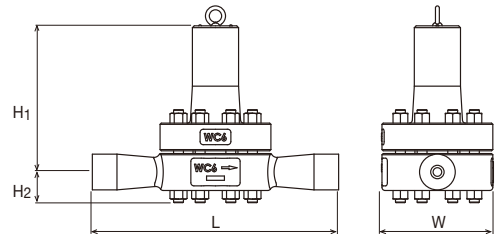

TBH72- ...F, TBH81- ...F, TBH82- ...F
Flanged

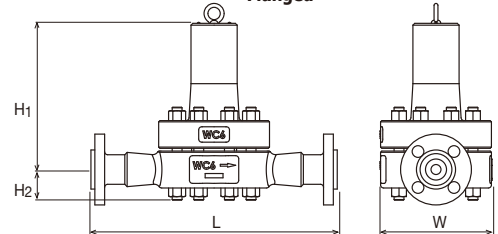

Standard factory settings

Model	MPa	psig	Model	MPa	psig
TBH71-80	6,5 (210°C)	942 (410°F)	TBH72-80	6,5 (210°C)	942 (410°F)
TBH71-105	8,0 (230°C)	1160 (446°F)	TBH72-105	8,0 (230°C)	1160 (446°F)
TBH81-150	10,5 (250°C)	1522 (482°F)	TBH82-150	10,5 (250°C)	1522 (482°F)
TBH81-200	15,0 (270°C)	2175 (518°F)	TBH82-200	15,0 (270°C)	2175 (518°F)

Pressure shell design conditions

Model	PMA		TMA	
	MPa	psig	°C	°F
TBH71-80	11,8 (425°C)	1711 (800°F)	593 (1,3MPa)	1100 (188 psig)
TBH71-105				
TBH72-80	25,0 (492°C)	3625 (918°F)	593 (3,7MPa)	1100 (536 psig)
TBH72-105				
TBH81-150	25,0 (492°C)	3625 (918°F)	593 (3,7MPa)	1100 (536 psig)
TBH81-200				
TBH82-150	25,0 (520°C)	3625 (968°F)	593 (5,9MPa)	1100 (856 psig)
TBH82-200	25,0 (538°C)	3625 (1000°F)	593 (7,3MPa)	1100 (1059 psig)

Model	Connections	Size	Max. Operating Pressure		Max. Operating Temperature		Adjustable Range		Dimensions (mm)				Dimensions (in)				Body Material	Weight	
			MPa	psig	°C	°F	°C	°F	L	H1	H2	W	L	H1	H2	W		kg	lb
TBH71-80W	Socket Weld JIS, ASME, DIN	½" – 1"	8,0	1160	470	878	100 – 260	212 – 500	250	195	33	140	9.8	7.7	1.3	5.5	Cast Steel A217WC6	13	28.6
TBH71-105W			10,5	1522			100 – 280	212 – 536										13	28.6
TBH81-150W			15,0	2175			100 – 300	212 – 572										29	63.8
TBH81-200W			20,0	2900			100 – 320	212 – 608										29	63.8
TBH71-80F	Flanged JIS, ASME, DIN	½" – 1"	8,0	1160	470	878	100 – 260	212 – 500	260	195	33	140	10.2	7.7	1.3	5.5	Cast Steel A217WC6	19*	41.8*
TBH71-105F			10,5	1522			100 – 280	212 – 536										19*	41.8*
TBH81-150F			15,0	2175			100 – 300	212 – 572										38*	83.6*
TBH81-200F			20,0	2900			100 – 320	212 – 608										38*	83.6*

Model	Connections	Size	Max. Operating Pressure		Max. Operating Temperature		Adjustable Range		Dimensions (mm)				Dimensions (in)				Body Material	Weight	
			MPa	psig	°C	°F	°C	°F	L	H1	H2	W	L	H1	H2	W		kg	lb
TBH72-80W	Socket Weld JIS, ASME, DIN	½" – 1"	8,0	1160	550	1022	100 – 260	212 – 500	400	268	50	180	15.8	10.6	2.0	7.1	A217WC6	29	63.8
TBH72-105W			10,5	1522			100 – 280	212 – 536										29	63.8
TBH82-150W			15,0	2175			100 – 300	212 – 572										37	81.4
TBH82-200W			20,0	2900			100 – 320	212 – 608										68	149.6
TBH72-80F	Flanged JIS, ASME, DIN	½" – 1"	8,0	1160	550	1022	100 – 260	212 – 500	400	268	50	180	15.8	10.6	2.0	7.1	A217WC6	35*	77.0*
TBH72-105F			10,5	1522			100 – 280	212 – 536										38*	83.6*
TBH82-150F			15,0	2175			100 – 300	212 – 572										46*	101.2*
TBH82-200F			20,0	2900			100 – 320	212 – 608										76*	167.2*

* The weight refers to 1" flanged type. Depending on the size and flange standard the weights may differ.

Forged Steel (A182F91) as body material for TBH72 and TBH82 is available as special design. For more details, please contact MIYAWAKI Inc. or an authorized representative.

Bimetal Temperature Control Traps – High Pressure **SERIES TB**

Capacity Charts

Temperature Stroke Charts

TBH71 - 80

TBH72 - 80

TBH71 - 80

TBH72 - 80

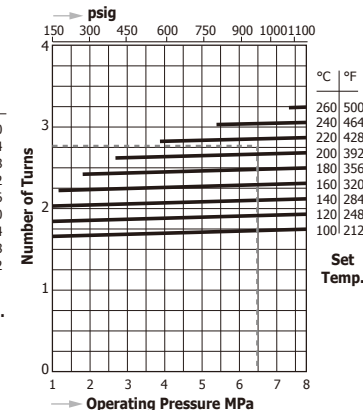
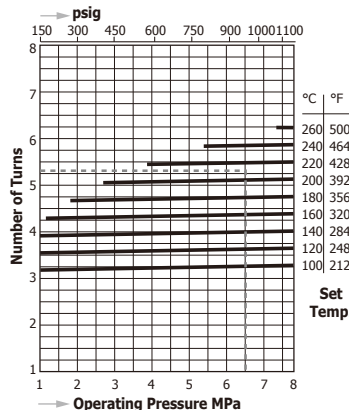
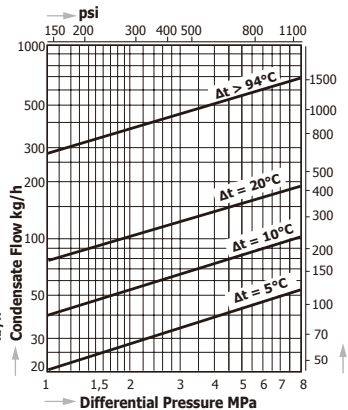
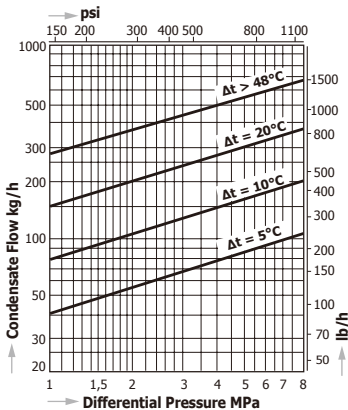

TBH71 - 105

TBH72 - 105

TBH71 - 105

TBH72 - 105

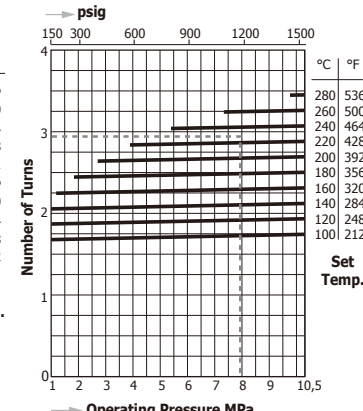
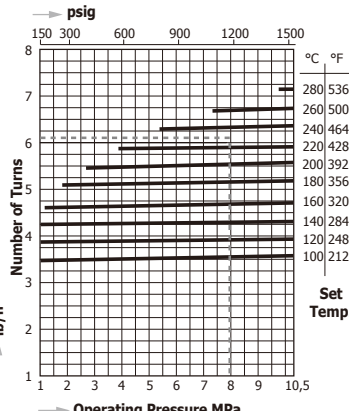
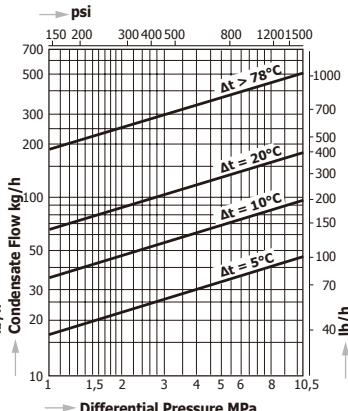
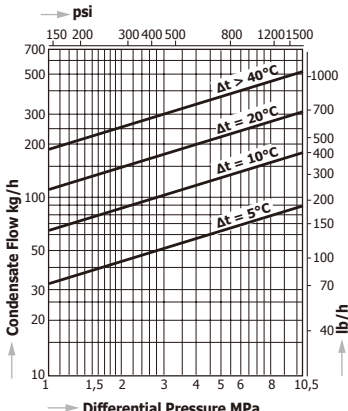

TBH81 - 150

TBH82 - 150

TBH81 - 150

TBH82 - 150

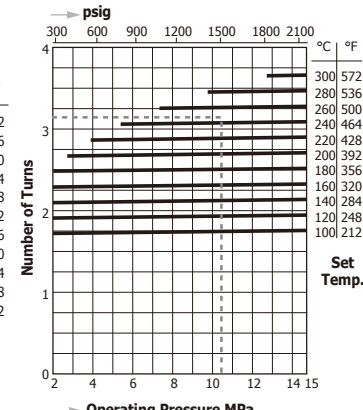
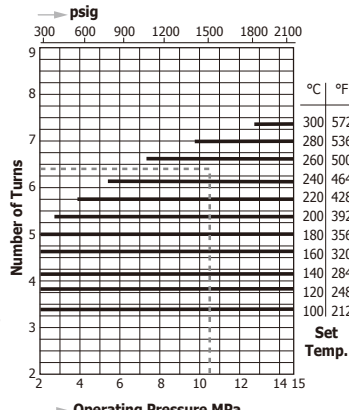
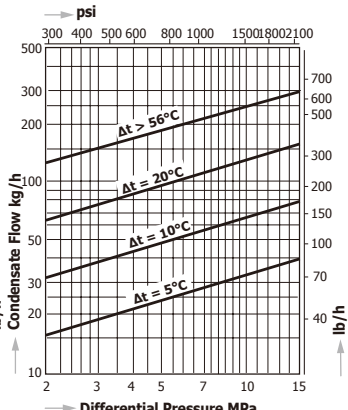
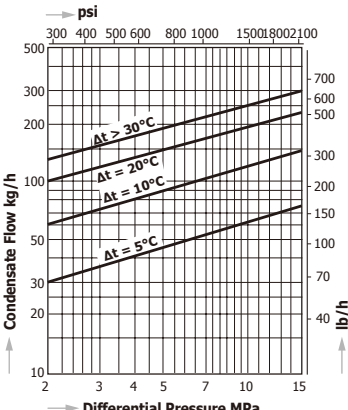

TBH81 - 200

TBH82 - 200

TBH81 - 200

TBH82 - 200

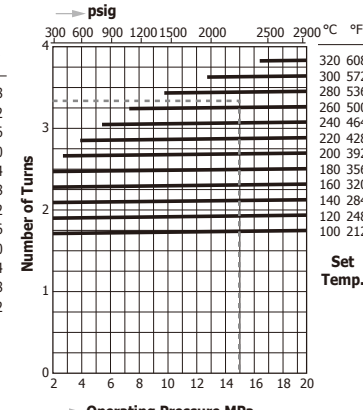
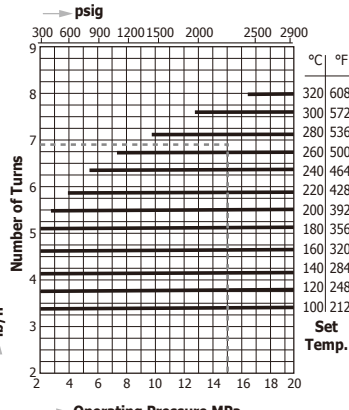
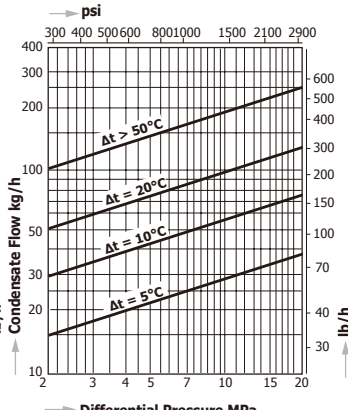
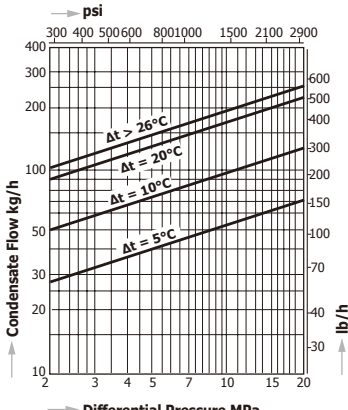

The dashed line shows the standard factory setting.

TB7N

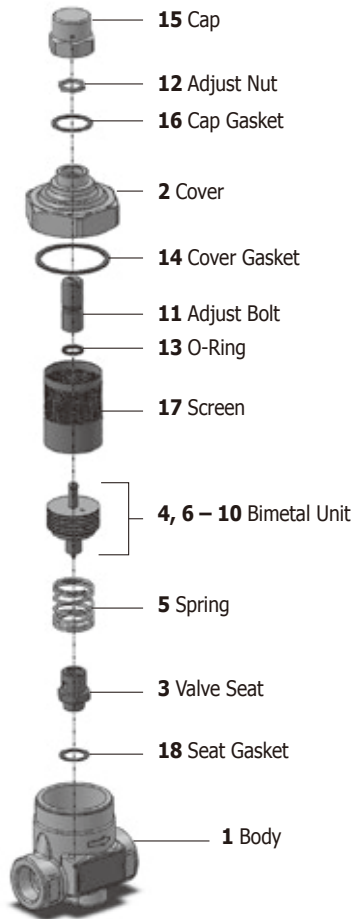

TB9N

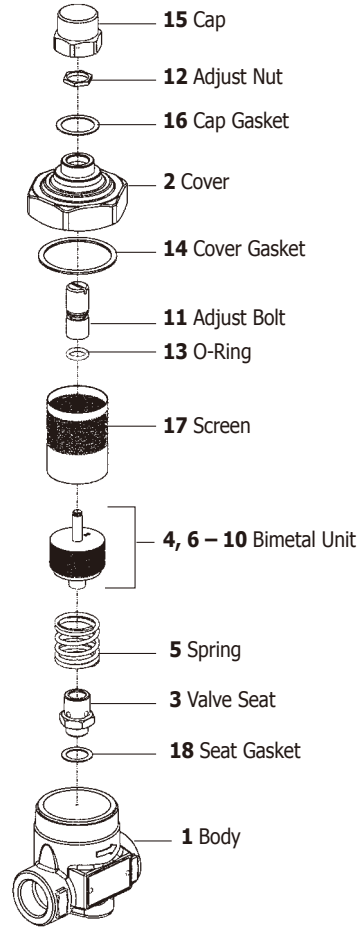

TBU4, TBU4B

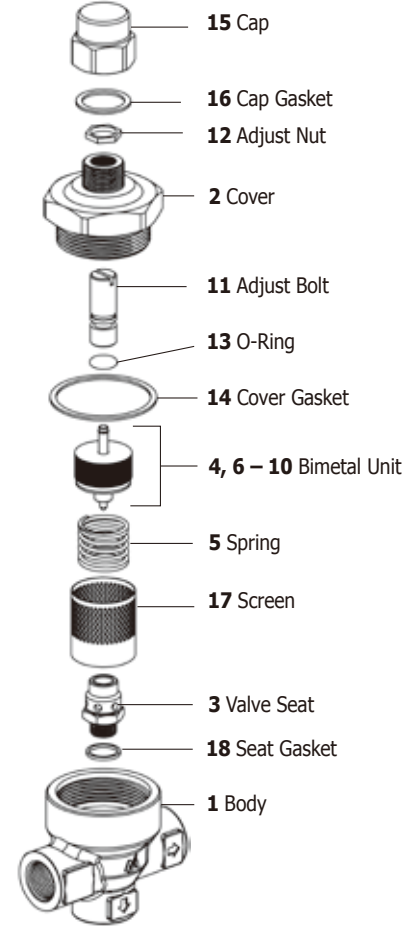

TB1N

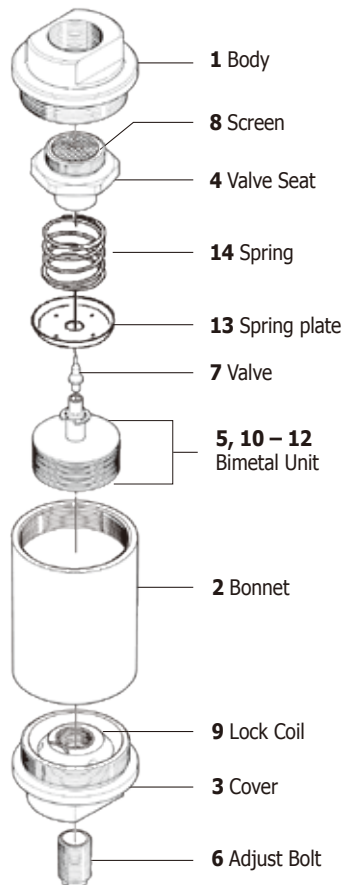

TB51, TB52

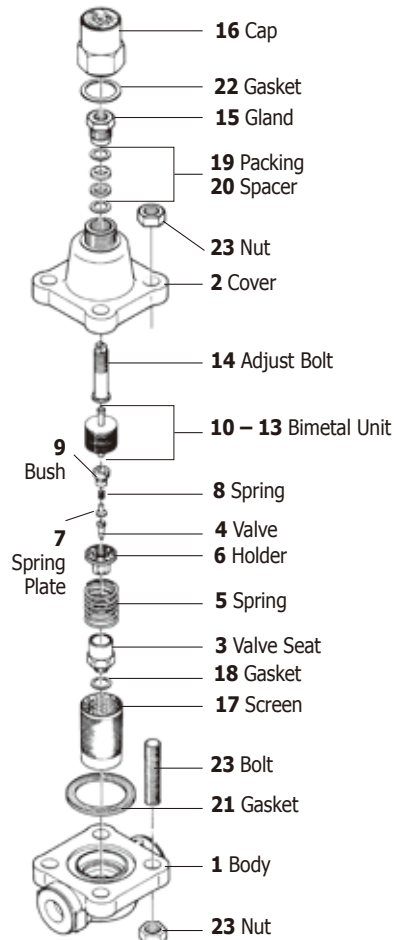

TBH71, TBH72, TBH81, TBH82

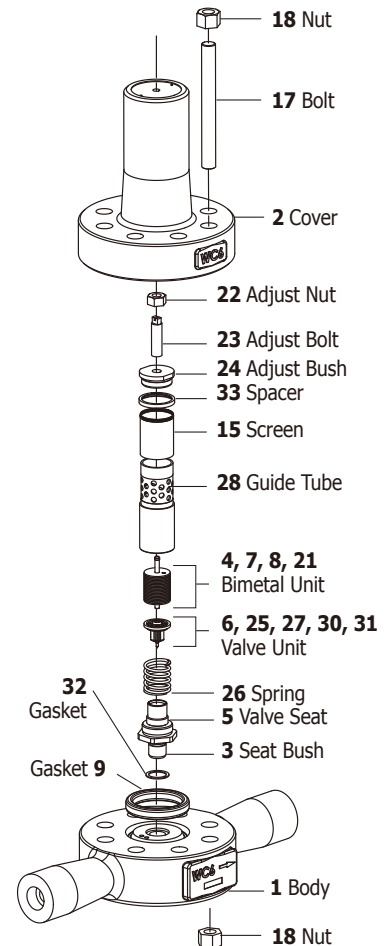

Thermostatic Radiator Traps

SERIES W

Thermostatic Radiator Traps are equipped with a Thermo-Element, which controls the discharge of condensate depending on the temperature. The Thermo-Element expands with the temperature, so below a certain temperature (depending on type) the trap is open and above that temperature it is closed.

Models

W1, W2, W3

With Forged brass body and stainless steel internals

Features

- Quick startup
- Operates below saturation temperature, resulting in no steam leaks and great energy saving performance.
- Dirt and scale are effectively discharged thanks to a generously designed valve hole and large flow surface area in the valve.
- The valve remains fully open once the operation stops and discharges condensate completely.
- Easy maintenance

Suitable for

Radiators

(Perfect for the radiator heating system in the hotel, school, hospital, and office sectors)

Operating Principle

 cold condensate  hot condensate

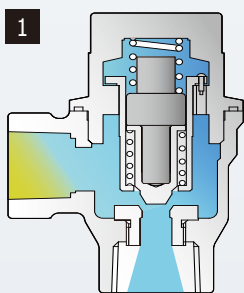

1 On start-up, the valve shaft is up with the valve fully open. Virtually all cold condensate and air are discharged.

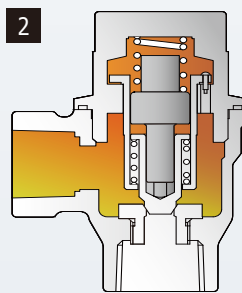

2 As the temperature of the condensate increases, the Thermo-Element begins to expand and forces the valve to move down. When the condensate temperature is above opening temperature of the valve (depending on type), the valve will close the seat completely.

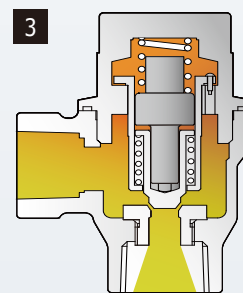

3 As the temperature of the condensate decreases, the Thermo-Element shrinks and the valve will open. Condensate will be discharged continuously at a stable temperature.

W

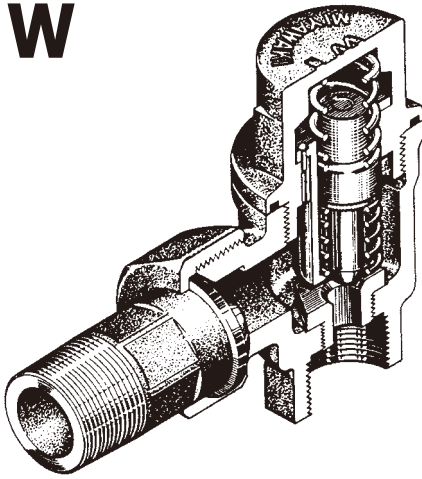

W1



W2

W1, W2, W3

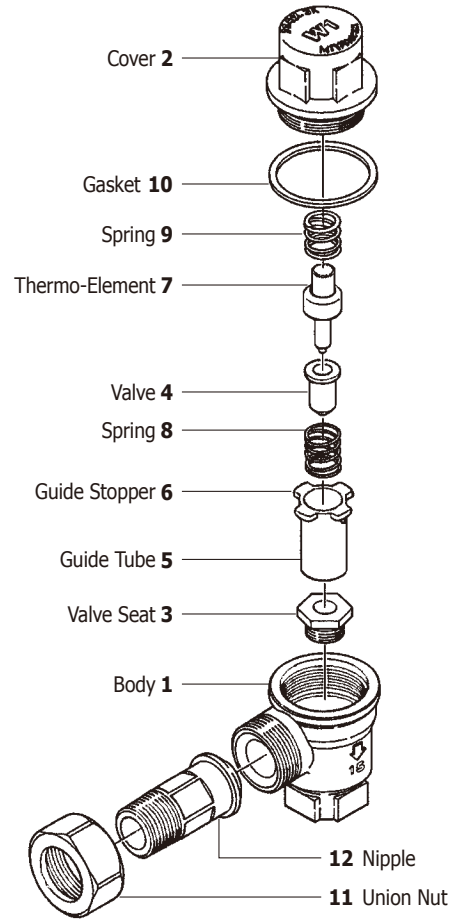

Capacity Chart W1, W2, W3

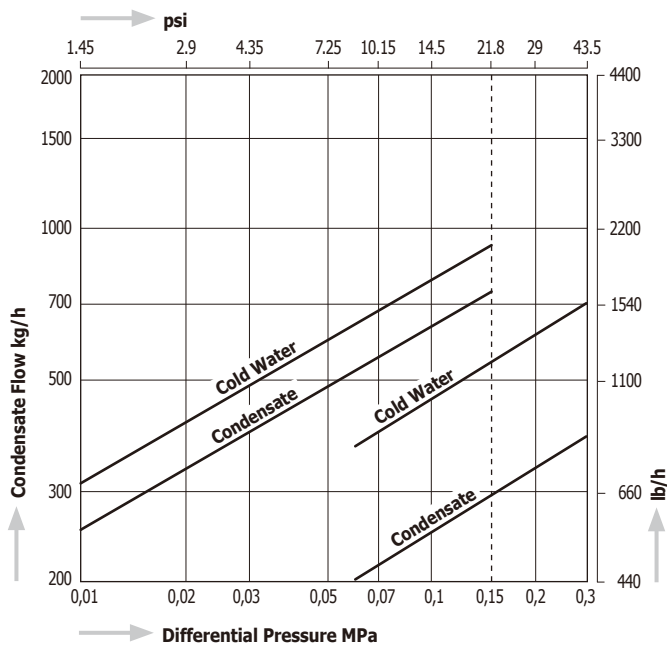

The opening temperature of the valve is preset

- at about 97°C (207° F) for W1-1,5, W2-1,5 and W3-1,5
- at about 115°C (239° F) for W1-3, W2-3 and W3-3

Dimensions

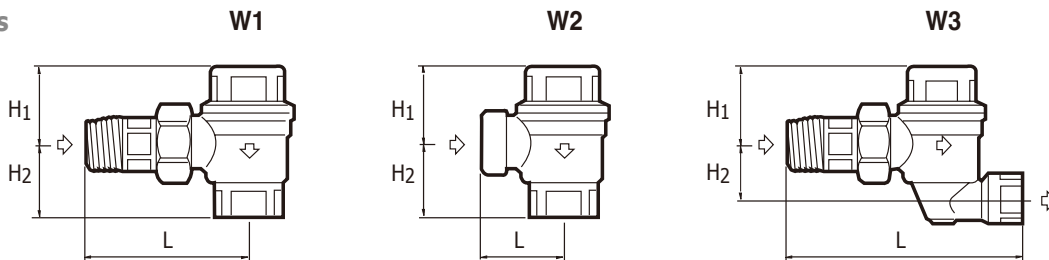

Model	Connections	Size	Max. Operating Pressure		Max. Operating Temperature		Dimensions (mm)			Dimensions (in)			Body Material	Weight				
			MPa	psig	°C	°F	L	H ₁	H ₂	L	H ₁	H ₂		kg	lb			
W1-1,5	Screwed Inlet : R Outlet : Rc, NPT	1/2"	0,15	21.8	150	302	80	35	3.1	1.4	Brass C3771	0,5	1.1					
		3/4"										0,6	1.3					
W1-3	Screwed Inlet : R Outlet : Rc, NPT	1/2"	0,3	43.5								80	35	3.1	1.4	Brass C3771	0,5	1.1
		3/4"															0,6	1.3
W2-1,5	Screwed Rc, NPT	1/2"	0,15	21.8	150	302	35	42	1.4	1.7	Brass C3771	0,4	0.9					
		3/4"										0,5	1.1					
W2-3	Screwed Rc, NPT	1/2"	0,3	43.5								35	41	1.4	1.6	Brass C3771	0,4	0.9
		3/4"															0,5	1.1
W3-1,5	Screwed Inlet : R Outlet : Rc, NPT	1/2"	0,15	21.8	150	302	123	28	4.8	1.1	Brass C3771	0,6	1.3					
		3/4"										0,7	1.5					
W3-3	Screwed Inlet : R Outlet : Rc, NPT	1/2"	0,3	43.5								123	28	4.8	1.1	Brass C3771	0,6	1.3
		3/4"															0,7	1.5

Balanced Pressure Thermostatic Steam Traps

SERIES D

Balanced Pressure Thermostatic Steam Traps are equipped with a capsule element, which controls the discharge of condensate depending on the temperature. The capsule contains a special liquid, whose saturation temperature at a given pressure is always lower than that of the water. It ensures a very accurate functioning of the steam trap and is self-adjusting.

The discharge characteristic follows the saturation curve independent from pressure changes and the condensate load. Series D MIYAWAKI steam traps can be delivered with 3 different capsule types:

- Types H & C** discharge hot condensate at approximately 5°C (9°F) below saturation temperature
Type L discharges hot condensate at approximately 15°C (27°F) below saturation temperature

- Models**
- DC1, DC2, DV1, DL1, DX1** with stainless steel body and internals
 - DF1** with forged steel body and stainless steel internals

- Features**
- Excellent air venting characteristics at start-up and during operation
 - The operation will not be influenced by back pressure
 - At time of non-operation self-draining
 - No steam loss throughout its operating range
 - All traps equipped with integral strainers
 - Can be installed both horizontally and vertically
 - Easy in-line inspection and maintenance
 - Lightweight, compact design

Suitable for

light to medium condensate loads: steam tracing, steam main drips, small heat exchangers, unit heaters, steam heating coils and many other applications in the petrochemical, chemical, textile, food, pharmaceutical and other industries.

Operating principle

■ cold condensate
 ■ hot condensate
 ■ steam

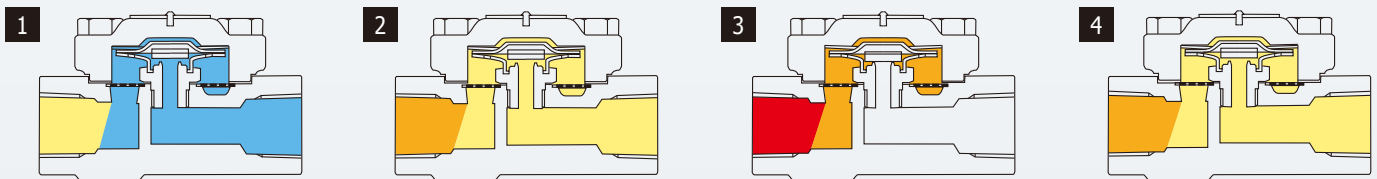

1 Upon start-up in the presence of cold condensate, the capsule element is contracted and the valve plate has moved away from the seat. The wide open valve discharges condensate and air rapidly.

2 As the temperature inside the trap increases, the capsule element will start to expand, moving the valve plate toward the seat.

3 Just before the condensate reaches saturation temperature, the valve plate will close the seat completely. Steam can not enter the trap, ensuring zero steam loss.

4 As the temperature inside the trap decreases, the capsule element moves away from the seat and the condensate will be discharged. During normal operation steps 3 and 4 will repeat continuously.

Operating principle of DV1 when using the bypass valve

When the handle is turned in the direction indicated by the BLOW arrow on the nameplate (counterclockwise), the bypass valve will open, a bypass circuit will be formed inside the trap, and a large volume of air and condensate can be discharged quickly. Scale that has accumulated in the screen can also be blown out.

When the bypass valve is closed, the type DV1 will operate as a normal steam trap (see above operating principle).

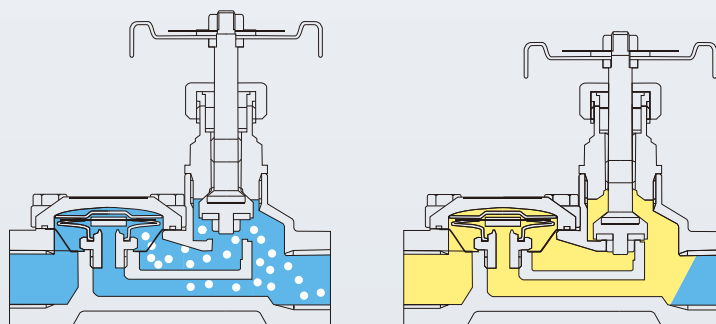

DC1

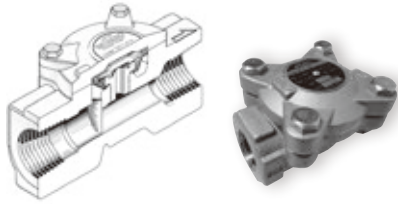

Capacity Chart DC1

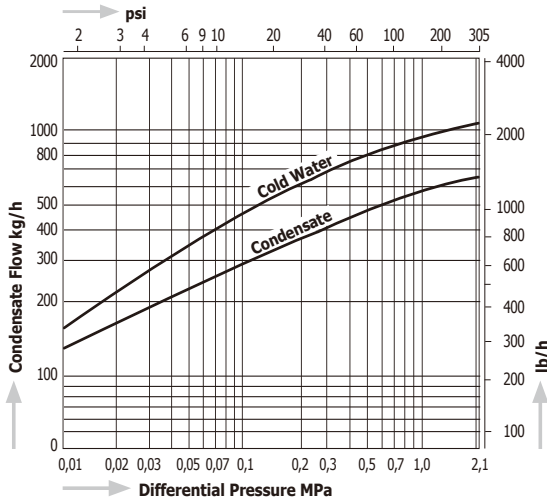

DC2

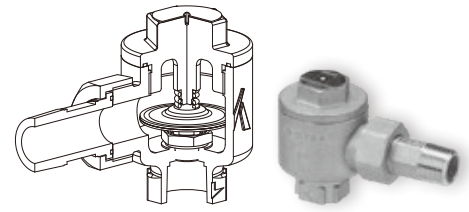

Capacity Chart DC2

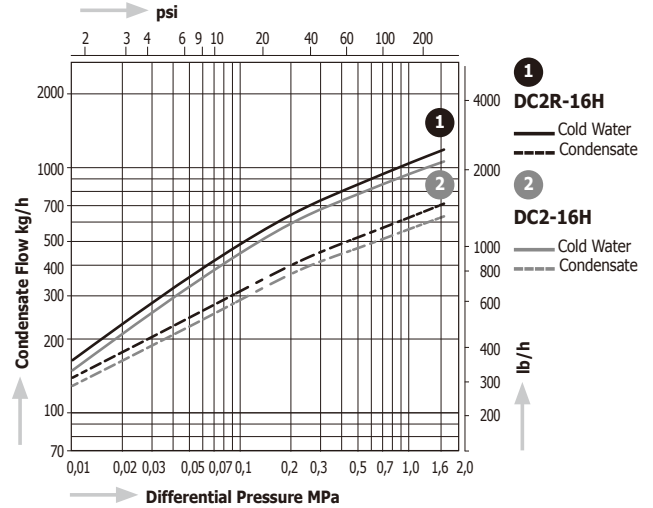

DV1 with Bypass Valve

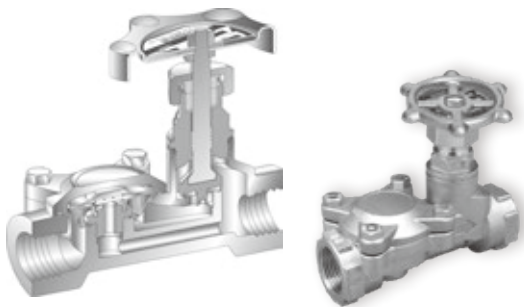

Capacity Chart DV1

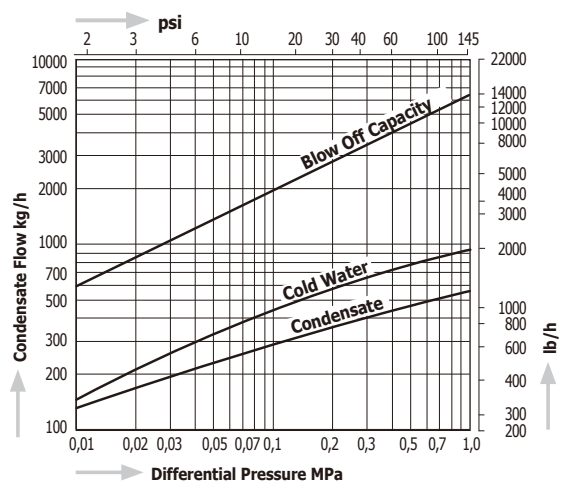

Dimensions

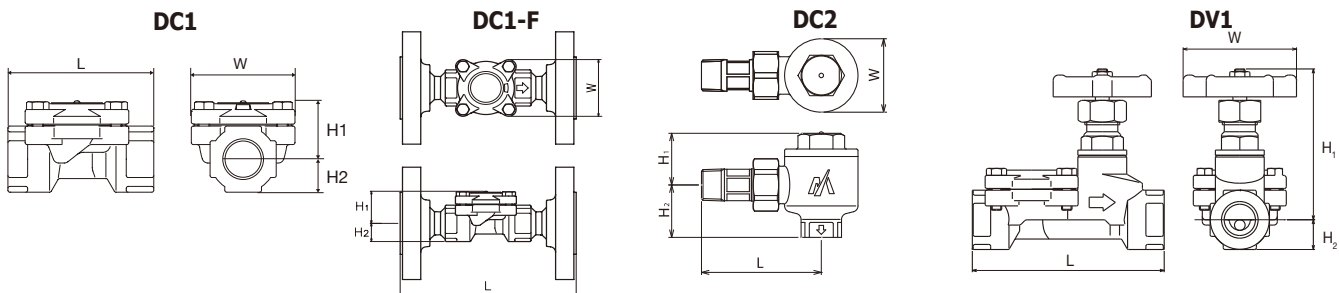

Model	Connections	Size	Max. Operating Pressure		Max. Operating Temperature		Dimensions (mm)				Dimensions (in)				Body Material	Weight	
			MPa	psig	°C	°F	L	H ₁	H ₂	W	L	H ₁	H ₂	W		kg	lb
DC1-21H DC1-21L	Screwed Rc, NPT	1/4", 3/8"	2,1	305	220	428	65	29	11	53	2.6	1.1	0.4	2.1	Stainless Steel SCS13A	0,4	0,9
		1/2", 3/4"					75	31	17		3.0	1.2	0.7			0,5	1,1
		1"					80	34	21		3.1	1.3	0.8			0,5	1,1
DC1-21HF DC1-21LF	Flanged JIS, ASME, DIN	1/2"	2,1	305	220	428	150	31	17	53	5.9	1.2	0.7	2.1	Stainless Steel SCS13A	1,3	2,9
		3/4"					160	34	21		6.3	1.3	0.8			2,2	4,9
		1"					160	34	21		6.3	1.3	0.8			3,1	6,8
DC2R-16H DC2-16H	Inlet: R Outlet: Rc, NPT	1/2"	1,6	230	220	428	80	35	35	49	3.1	1.4	1.4	1.9	Stainless Steel SCS13A	0,7	1,5
DV1-10	Screwed Rc, NPT	1/2", 3/4"	1,0	145	185	365	110	88	17	65	4.3	3.5	0.7	2.6	Stainless Steel SCS13A	0,9	1,9

DC2R-16H – Type with bypass orifice to prevent residue of condensate in steam traps.

DL1

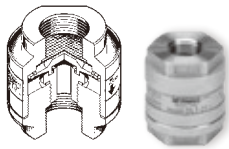

DX1



DF1

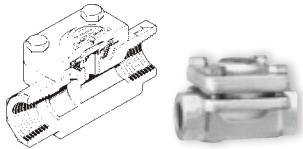

Dimensions

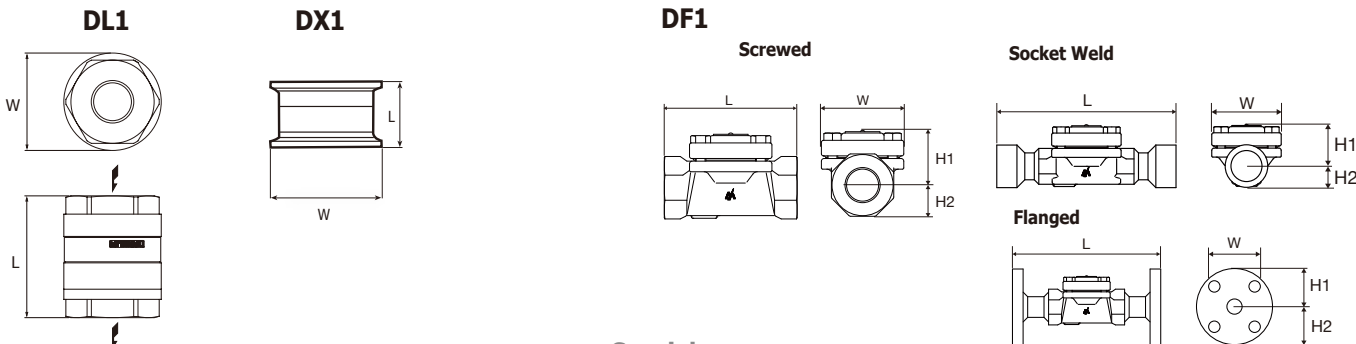

Special face-to-face dimensions available.

Capacity Chart DL1, DF1

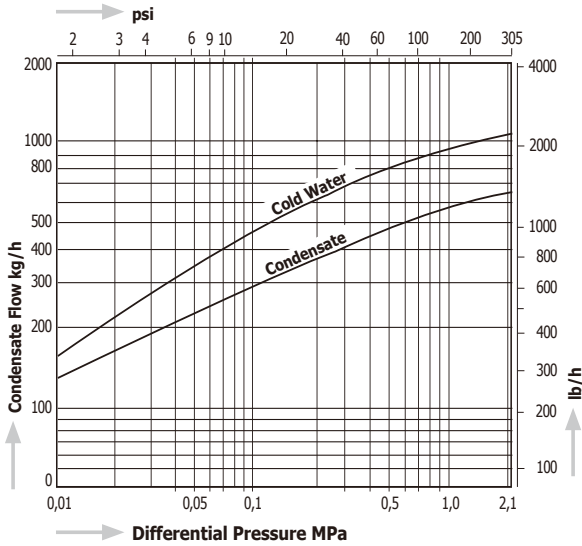

Capacity Chart DX1

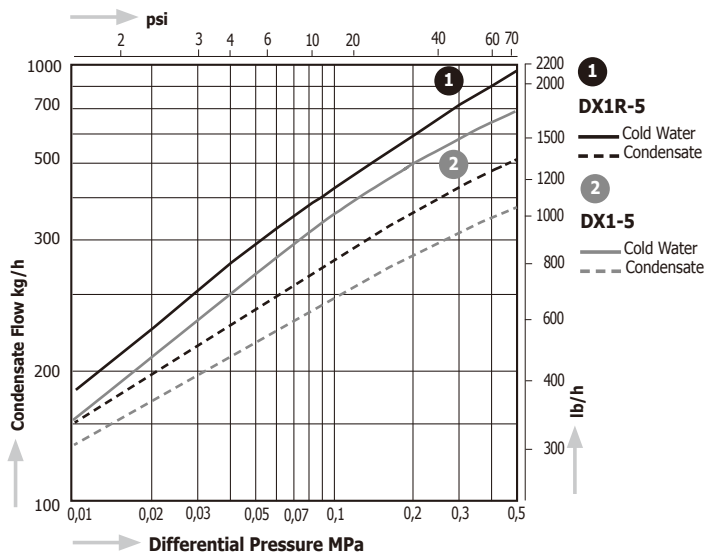

Model	Connections	Size	Max. Operating Pressure		Max. Operating Temperature		Dimensions (mm)				Dimensions (in)				Body Material	Weight						
			MPa	psig	°C	°F	L	H1	H2	W	L	H1	H2	W		kg	lb					
DL1-21H DL1-21L	Screwed Rc, NPT	1/4"	2,1	305	220	428	60	-	-	48	2.4	-	-	1.9	Stainless Steel SCS13	0,7	1.5					
		3/8"																				
		1/2"																				
		3/4"																				
DL1-10C	Screwed Rc, NPT	1/4"	1,0	145	220	428	60	-	-	48	2.4	-	-	1.9	Stainless Steel SCS13	0,7	1.5					
		3/8"																				
		1/2"																				
		3/4"																				
DX1-5 DX1R-5	Tri-Clamp	38 mm	0,5	72.5	160	320	30	-	-	51	1.2	-	-	2.0	Stainless Steel SUS316	0,18	0.4					
		1"																				
DF1-21H DF1-21L	Screwed Rc, NPT	1/2"	2,1	305	235	455	85	36	18	62	3.4	1.4	0.7	2.4	Forged Steel A105	1,0	2.2					
		100					40	23	3.9		1.6	0.9	1,3			2.9						
		1"																				
DF1-21HW DF1-21LW	Socket Weld JIS, ASME, DIN	1/2"	2,1	305	235	455	160	36	18	62	6.3	1.4	0.7	2.4	Forged Steel A105	1,4	3.1					
		3/4"																				
		1"																				
		1"																				
DF1-21HF DF1-21LF	Flanged JIS, ASME 150, 300 lb	1/2"	2,1	305	235	455	175	36	18	62	6.9	1.4	0.7	2.4	Forged Steel A105	2,1	4.6					
		3/4"									7.7	1.6	0.9			3,3	7.3					
		1"									8.5	1.6	0.9			4,0	8.8					
	Flanged DIN PN40	DN15									150	36	18			62	5.9	1.4	0.7	2.4	2,3	5.0
		DN20									160	36	18			62	6.3	1.4	0.7	2.4	3,6	7.9
		DN25									160	36	18			62	6.3	1.4	0.7	2.4	4,3	9.5

DX1R-5 – Type with bypass orifice to prevent residue of condensate in steam traps.

DV1

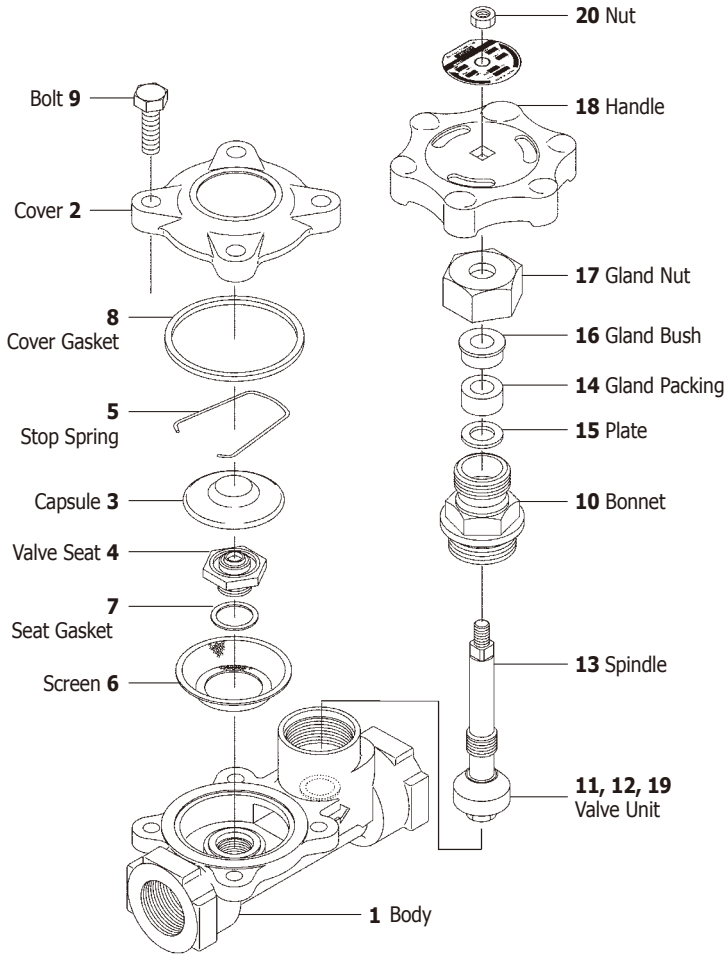

DC2

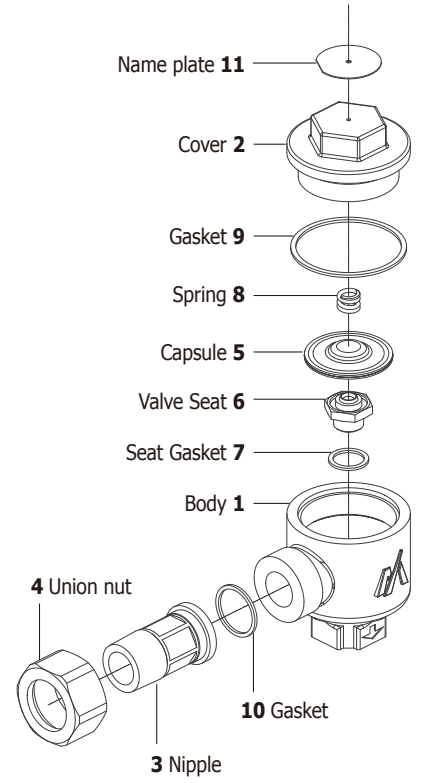

DC1

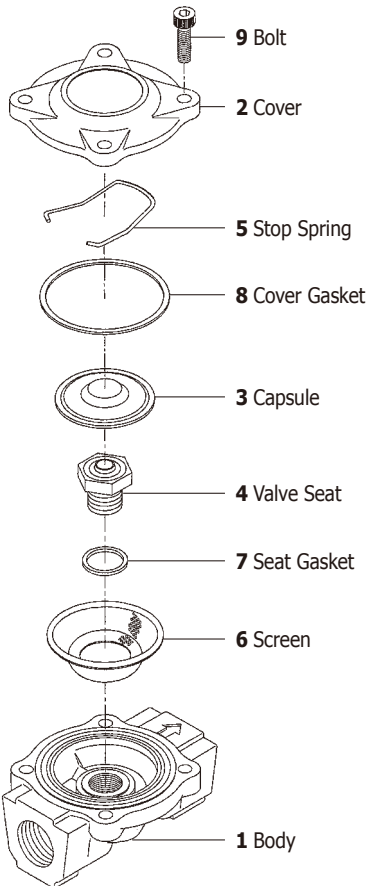

DL1

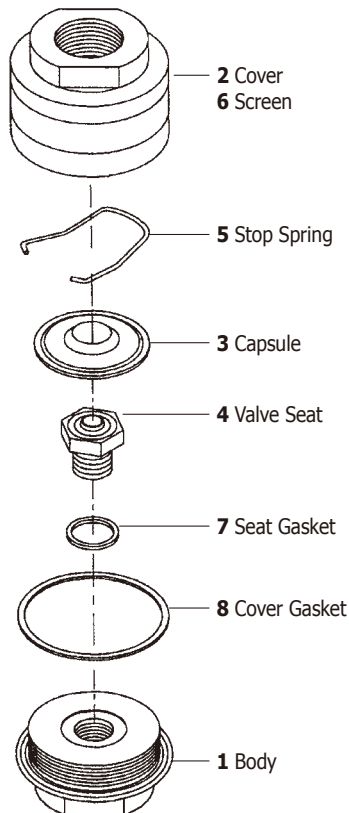

DF1

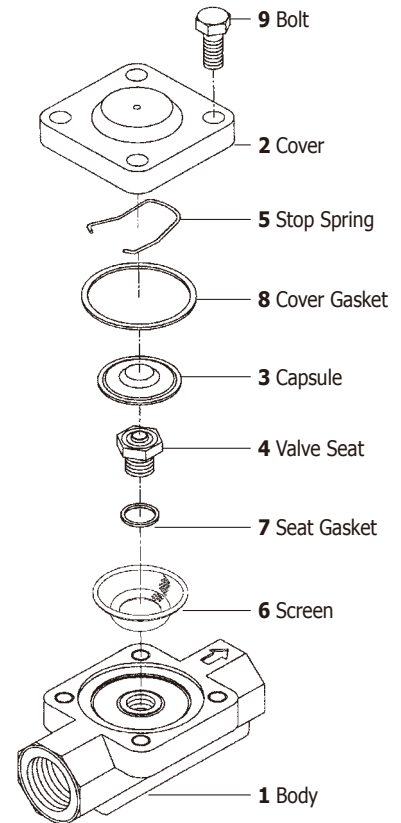

Thermodynamic Disc Traps

SERIES S

Thermodynamic steam traps operate on the basis of the Bernoulli principle, depending on the relationship between the velocity and the pressure exerted by the condensate and steam inside the steam trap.

They have only one moving part – the disc.

Due to their compact design and cost effectiveness thermodynamic steam traps are widely used in applications where the condensate must be removed immediately from steam lines and steam equipment. They discharge the condensate near the saturation temperature. The traps may operate up to a back pressure of 80% of the inlet pressure, but for smooth operation it is recommended that the back pressure does not exceed 50% of the inlet pressure. Thermodynamic steam traps discharge the condensate intermittently.

All steam traps are equipped with a hardened stainless steel disc and seat. After the lapping process all disc surfaces are controlled individually before releasing them for use in steam traps. These features and very high and severe quality standards for the whole production process give MIYAWAKI's thermodynamic steam traps a long and reliable service life.

Models S31N

Ductile Cast Iron Steam Traps with replaceable internals

SC31

Stainless steel steam traps with replaceable internals

SC, SF

Cast Iron Steam Traps for high capacity

SV

Steam Traps with inbuilt bypass

SL3

Compact, very small trap for low capacity applications

SU2N, SU2H, SD1

Stainless steel steam traps for low to high pressure applications

S55N, S55H, S61N, S62N

Forged steel steam traps for high pressure applications

Features

- Immediate discharge of condensate
- Insensitive to waterhammer, superheated steam and freezing
- Most types contain a bimetal ring which improves the ability of the trap to discharge air and cold condensate quickly at start-up and prevents air locking during times of operation
- Can be installed in vertical or horizontal position
- In case of danger of air locking special discs available
- All traps equipped with additional cover for reduced frequency of cycling and energy savings
- All traps with inbuilt strainers (except SL3)
- Easy maintenance

Suitable for

light to medium condensate loads: steam tracing, steam main drips, small heat exchangers, unit heaters, sterilizers and many other applications in the petrochemical, chemical, textile, food, pharmaceutical and further industries. Series SV Thermodynamic steam traps with inbuilt bypass are designed for special applications in the food, pharmaceutical or other industries or for laundry applications where costs and space must be saved.

Operating principle

■ cold condensate ■ hot condensate ■ steam

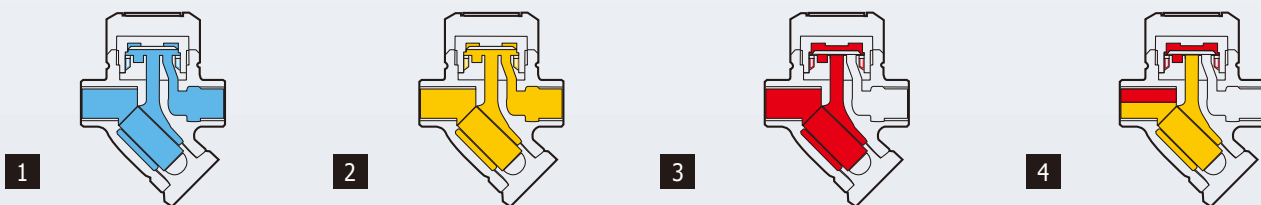

1 At the time of start-up the pressure of the incoming cold condensate and air raise the disc and water and air are discharged quickly.

2 When hot condensate flows into the trap, the trap is still open and the hot condensate can be discharged quickly.

3 After hot condensate flows into the trap, steam enters it. As the velocity of the fluid increases, the pressure under the seat exerted by the steam decreases. At the same time the pressure in the pressure chamber above the disc increases. The disc is pressed down and closes.

4 While hot condensate flows into the trap, the trap remains closed for a certain period, as far as the steam inside the pressure chamber does not condense. The more condensate flows into the trap, the more the temperature cools down. The steam inside the pressure chamber also cools down and condenses. As a result, the pressure of the incoming condensate raises the disc and condensate is discharged. Cycles 2, 3 and 4 repeat.

S31N, SC31

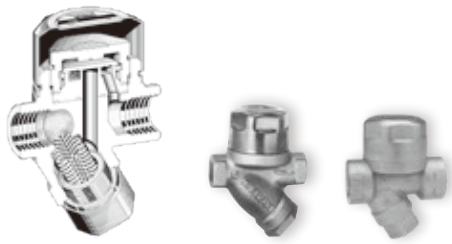

Capacity Chart

SC31 & SC31F/S31N & S31NF 1/2" – 1"

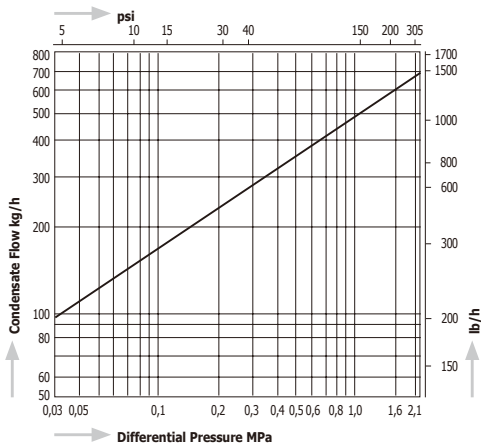

SC, SF

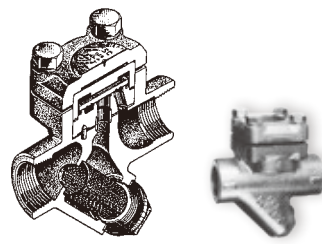

Capacity Chart

S31N & S31NF 1 1/4" – 2"; SC-310, SC-311 & SF-340, SF-341

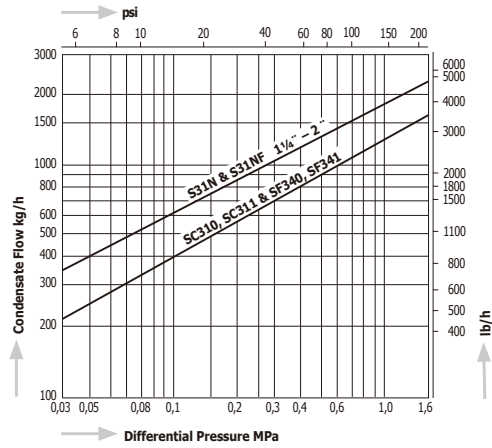

Dimensions

S31N/SC31 1/2" – 1"

S31NF 1/2" – 1"

SC31F 1/2" – 1"

S31N 1 1/4" – 2"
SC-310, SC-311

S31NF 1 1/4" – 2"
SF-340, SF-341

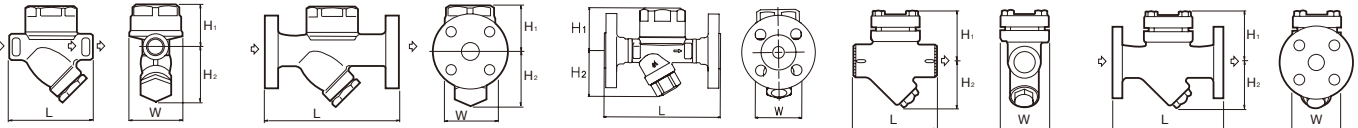

Model	Connections	Size	Max. Operating Pressure		Max. Operating Temperature		Dimensions (mm)				Dimensions (in)				Body Material	Weight														
			MPa	psig	°C	°F	L	H ₁	H ₂	W	L	H ₁	H ₂	W		kg	lb													
SC31	Screwed Rc, Rp, NPT	1/2"	2,1	305	220	428	78	55	61	61	3.1	2.2	2.4	2.3	2.4	Stainless Steel SCS14	1,0	2,2												
		90					3.5	1,3			2,9																			
		1"					3.7	1,2			2,6																			
143	5.6	2,3-2,9 *1					5.1-6.4 *1																							
155	6.1	2,9-3,9 *1					6.4-8.6 *1																							
175	6.9	3,6-4,7 *1					7.9-10.3 *1																							
SC31F	Flanged JIS, ASME	1/2"					2,1	305			220	428				185	7.3	61	61	2.4	2.3	2.4	2.4	Stainless Steel SCS14+SUSF304	4,2-5,5 *1	9.3-12.1 *1				
		1 1/4"														5,0-7,3 *1	11.0-16.0 *1													
		1 1/2"														6,1-8,2 *1	13.4-18.1 *1													
		2"														7,7	2,7								6,0					
		DN15														5,9	3,9								8,6					
		DN20														6,3	4,7								10,4					
SC31F	Flanged DIN	DN25	2,1	305	220	428	150	5.9	61	61	2.4	2.3	2.4	Stainless Steel SCS14+SUSF304	2,7	6,0														
		160					6,3	3,9							8,6															
S31N	Screwed Rc, NPT	1/2"	1,6	230	220	428	90	55	60	60	3.5	2.2	2.6	2.4	Ductile Cast Iron FCD450	1,1	2,4													
		3/4"					60	65			2.4	2,6																		
		1"					3.7	1,3			2,9																			
		1 1/4"					180	104			100	106				7.1	4.1	3.9	4.2	Cast Iron FC250	8,0	17,6								
		1 1/2"					111	4.4			9,3	20,5																		
2"	140	55					5.5	2.2			2,5	5,5																		
S31NF	Flanged JIS, ASME, DIN	1/2"					1,6	230			220	428			150	60	60	60	5.9	2.4	2.6	2.4	Ductile Cast Iron FCD450	3,0	6,6					
		3/4"													160	6.3			4,2	9,3										
		1"													240	104			100	106				9.5	4.1	3.9	4.2	Cast Iron FC250	12,0	26,4
		1 1/4"													13,5	29,8														
		1 1/2"													14,5	32,0														
2"	180	87					7.1	3.4			6,0	13,2																		
SC - 310 311	Screwed Rc, NPT	3/4"					1,6	230							220	428	240	89	96	9.5	3.5	3.2	3.8	Cast Iron FC250	10,0	22,0				
		1"									9.5	3.5								10,0	22,0									
SF - 340 341	Flanged JIS, ASME, DIN	3/4"					1,6	230			220	428			240	89	96	9.5	3.5	3.2	3.8	Cast Iron FC250	10,0	22,0						
		1"	9.5	3.5	10,0	22,0																								

*1 Depending on size and flange standard the weight of the traps differs. Please, look at our technical drawings.

SV

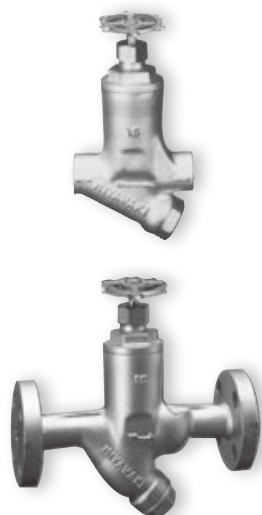
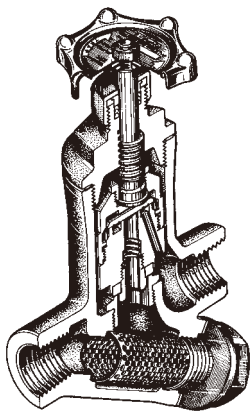

SL3

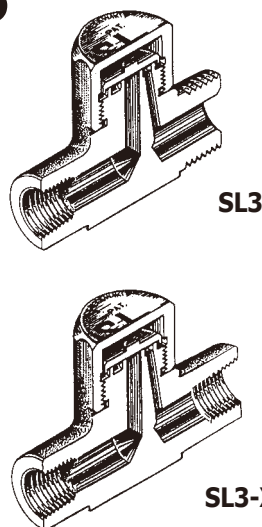

Capacity Chart SV-N

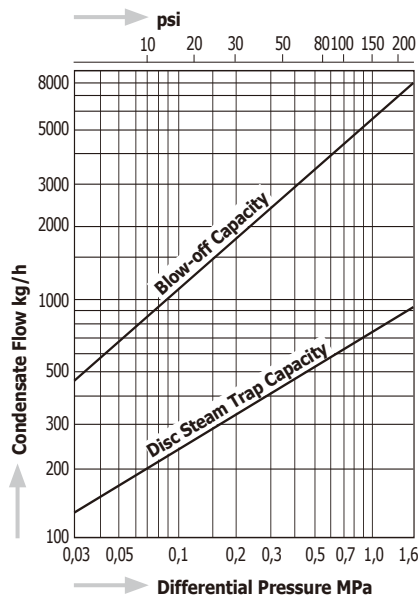

Capacity Chart SV1

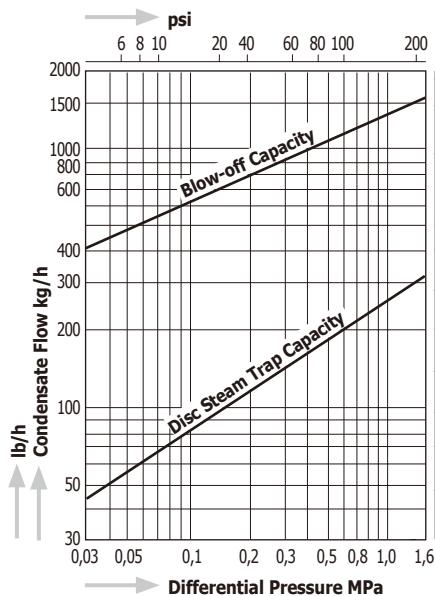

Capacity Chart SL3

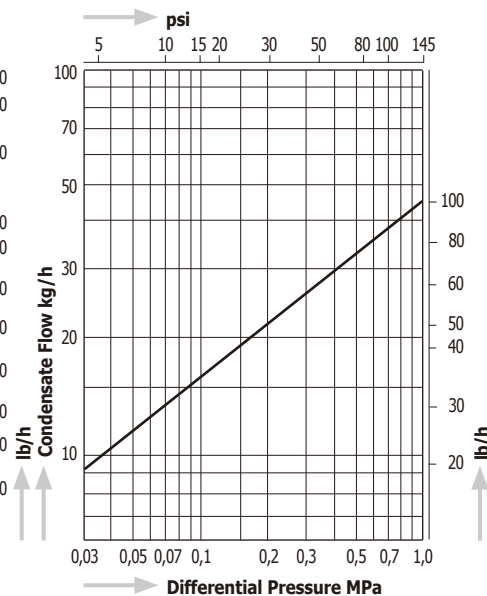

Dimensions

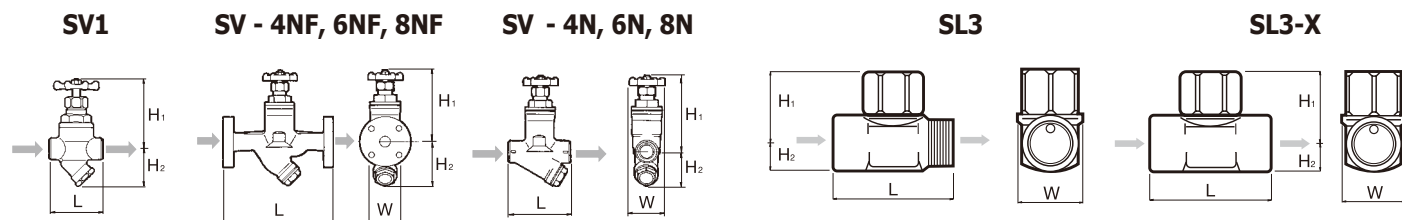

Model	Connections	Size	Max. Operating Pressure		Max. Operating Temperature		Dimensions (mm)				Dimensions (in)				Body Material	Weight					
			MPa	psig	°C	°F	L	H ₁	H ₂	W	L	H ₁	H ₂	W		kg	lb				
SV1	Screwed Rc, NPT	3/8", 1/2"	1,6	230	220	428	75	105	53	65	3.0	4.1	2.1	2.6	Cast Steel WCB	1,0	2.2				
		3/4", 1"						4.2				1,3				2.9					
SV -	Screwed Rc, NPT	1/2"	1,6	230	220	428	110	60	65	65	4.3	6.1	2.6	Cast Iron FC250	2,4	5.3					
		3/4"													2,5	5.5					
		1"													2,7	6.0					
	Flanged JIS, ASME, DIN	1/2"						220				150	90		65	8.7	5.9	3.5	2.6	4,1	9.0
		3/4"																		4,7	10.3
		1"																		6,5	14.3
SL3	Screwed Inlet : Rc, NPT Outlet: G	1/4"	1,0	145	400	752	40	22	8	19	1.6	0.9	0.3	0.7	Stainless Steel SUS416	0,06	0.13				
SL3-X	Screwed Rc, NPT	1/4"	1,0	145	400	752	40	22	8	19	1.6	0.9	0.3	0.7		0,06	0.13				

SU2N, SU2H

SD1

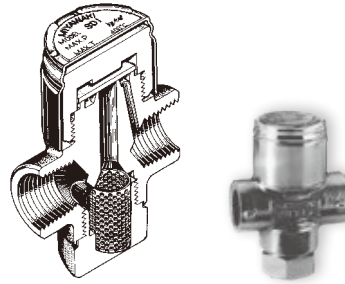
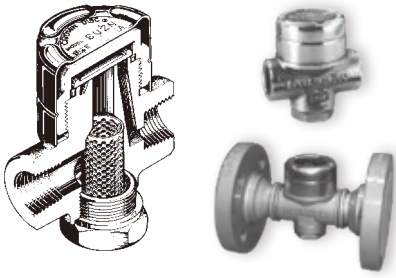

Special face-to-face dimensions available.

Capacity Chart SU2N, SU2H

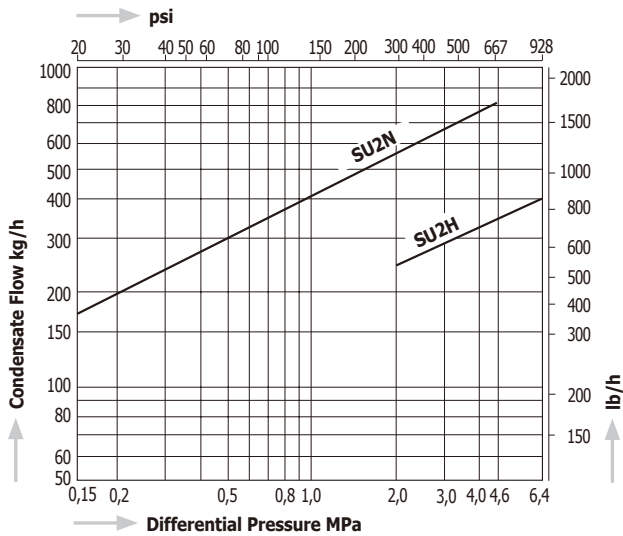

Capacity Chart SD1

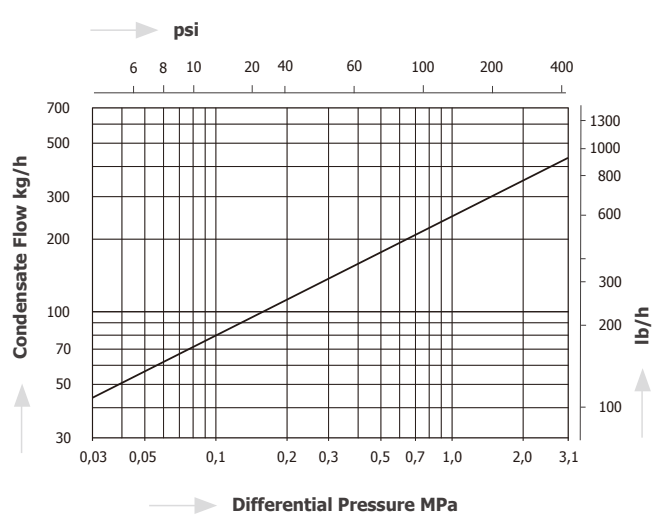
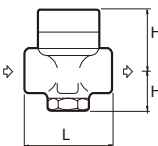

Table 1: Dimensions L and Weights

Model	Size	Dimension L		DIN PN40		DIN PN63/100	
		mm	in	kg	lb	kg	lb
SU2NF SU2HF	DN15	150	5.9	2,6	5,7	4,0	8,8
	DN20			3,6	7,9	5,8	12,8
	DN25	160	6.3	4,2	9,3	7,1	15,7

Dimensions

SU2N, SU2H



SU2NF, SU2HF

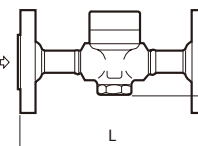

SU2NW, SU2HW

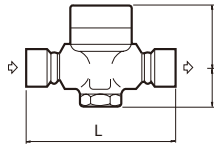

SD1

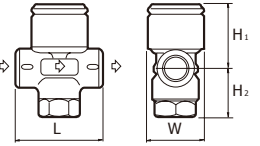

Model	Size	Dimension L		JIS 10K/16K/20K		JIS 30K		JIS 40K		JIS 63K		ASME 150lb		ASME 300lb		ASME 600lb		ASME 900lb	
		mm	in	kg	lb	kg	lb	kg	lb	kg	lb	kg	lb	kg	lb	kg	lb	kg	lb
SU2NF SU2HF	1/2"	205	8.1	2,6	5,7	3,8	8,4	4,1	9,0	4,9	10,8	2,2	4,9	2,7	6,0	3,3	7,3	5,7	12,6
	3/4"			3,0	6,6	4,1	9,0	4,4	9,7	6,2	13,7	2,6	5,7	3,7	8,2	4,6	10,1	7,1	15,7
	1"			4,4	8,8	5,0	11,0	5,4	11,9	7,0	15,4	3,0	6,6	4,3	9,5	5,4	11,9	9,6	21,2

Applicability of flange standards: JIS 10K/16K and ASME 150lb for SU2NF only
JIS 63K and ASME 900 lb for SU2HF only

Model	Connections	Size	Max. Operating Pressure		Max. Operating Temperature		Dimensions (mm)				Dimensions (in)				Body Material	Weight	
			MPa	psig	°C	°F	L	H1	H2	W	L	H1	H2	W		kg	lb
SU2N (SU2H)	Screwed Rc, NPT	1/2"	4,6 (6,4)	667 (928)	425	800	70	47	32	53	2.8	1.9	1.3	2.1	Stainless Steel SUS420J2	0,8	1,8
		3/4"					75	51			3.0	2.0				1,0	2,2
		1"															
SU2NW (SU2HW)	Socket Weld JIS, ASME, DIN	1/2"	4,6 (6,4)	667 (928)	425	800	140	47	32	53	5.5	1.9	1.3	2.1	Stainless Steel SUS420J2	1,5	3,3
		3/4"					140	47			5.5	1.9				1,4	3,1
		1"															
SU2NF (SU2HF)	Flanged JIS, ASME, DIN	1/2"	4,6 (6,4)	667 (928)	425	800	Table1	47	32	53	Table1	1.9	1.3	2.1	Stainless Steel SUS420J2	Table1	Table1
		3/4"															
		1"															
SD1	Screwed Rc, NPT	1/4"	3,1	450	400	752	52	39	25	34	2.0	1.5	1.0	1.3	Stainless Steel SUS420J2	0,3	0,7
		3/8"					60	41			2.4	1.6					
		1/2"															

S55N, S55H

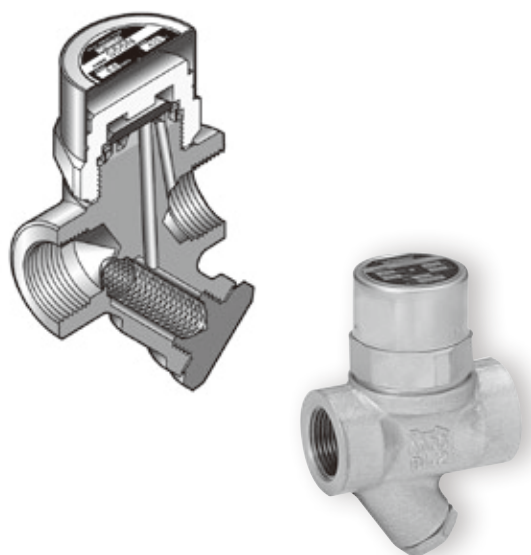

Capacity Chart S55N, S55H

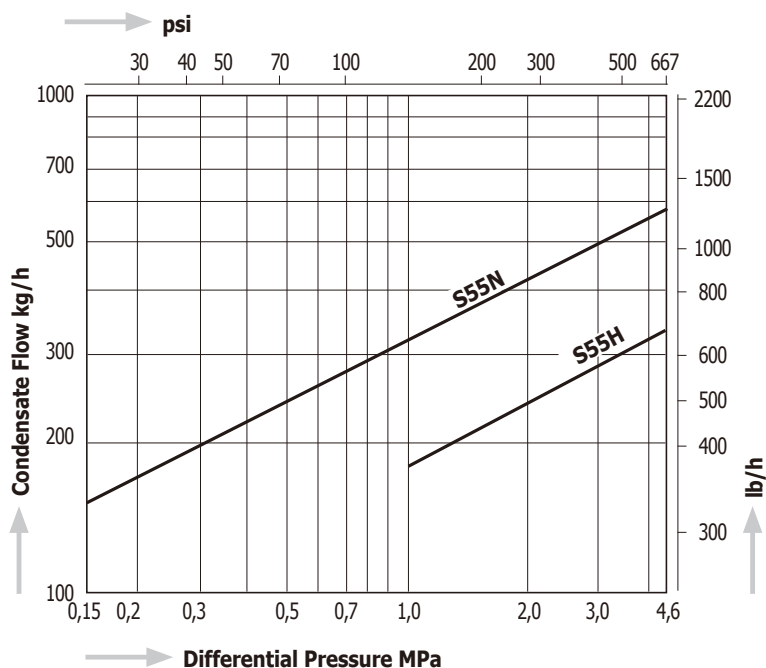

Dimensions

**S55N, S55H,
S55NW, S55HW**

S55NF, S55HF

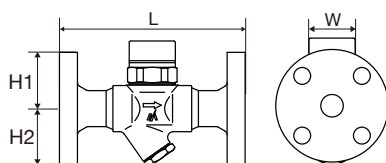
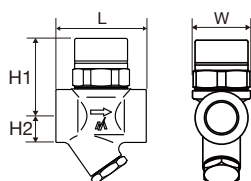
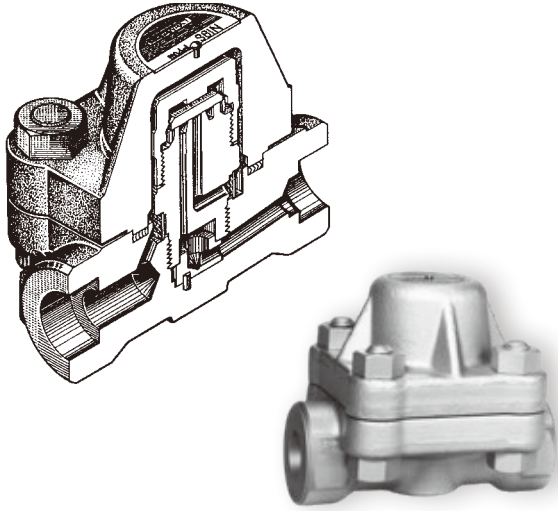

Table 1: Weights

Model	Size	JIS 10/16K		JIS 20K		JIS 30/40K		ASME 150lb		ASME 300lb		ASME 600lb		DIN PN40		DIN PN100	
		kg	lb	kg	lb	kg	lb	kg	lb	kg	lb	kg	lb	kg	lb	kg	lb
S55NF S55HF	1/2"	2,6	5,7	2,8	6,2	4,0	8,8	2,6	5,7	3,1	6,8	3,2	7,1	3,1	6,8	3,7	8,2
	3/4"	3,1	6,8	3,3	7,3	4,4	9,7	3,1	6,8	4,0	8,8	4,2	9,3	3,7	8,2	5,3	11,7
	1"	4,2	9,3	4,5	9,9	5,6	12,4	4,2	9,3	5,5	12,1	5,7	12,6	4,4	9,7	6,3	13,9

Model	Connections	Size	Max. Operating Pressure		Max. Operating Temperature		Dimensions (mm)				Dimensions (in)				Body Material	Weight	
			MPa	psig	°C	°F	L	H1	H2	W	L	H1	H2	W		kg	lb
S55N (S55H)	Screwed Rc, NPT	1/2"	4,6	667	425	800	70	60	52	45	2.8	2.4	2.0	1.8	Forged Steel A105	1,0	2,2
		3/4"					75	65	56	3.0	2.6	2.2	1,2			2,6	
		1"					140	5.5	1,2	2,6							
S55NF (S55HF)	Flanged JIS, ASME	1/2"					140	5.5	1,2	2,6							
		3/4"					165	60	52	45	6.5	2.4	2.0	1.8		Table1	Table1
		1"					175	6.9	Table1	Table1							
S55NF (S55HF)	Flanged DIN	DN15					150	60	52	45	5.9	2.4	2.0	1.8		Table1	Table1
		DN20					160	6.3	Table1	Table1							
		DN25					Table1	Table1									
S55NW (S55HW)	Socket Weld JIS, ASME, DIN	1/2"	70	60	52	45	2.8	2.4	2.0	1.8	1,0	2,2					
		3/4"	75	65	56	3.0	2.6	2.2	1,2		2,6						
		1"	Table1	Table1													

S61N, S62N



Capacity Chart S61N, S62N

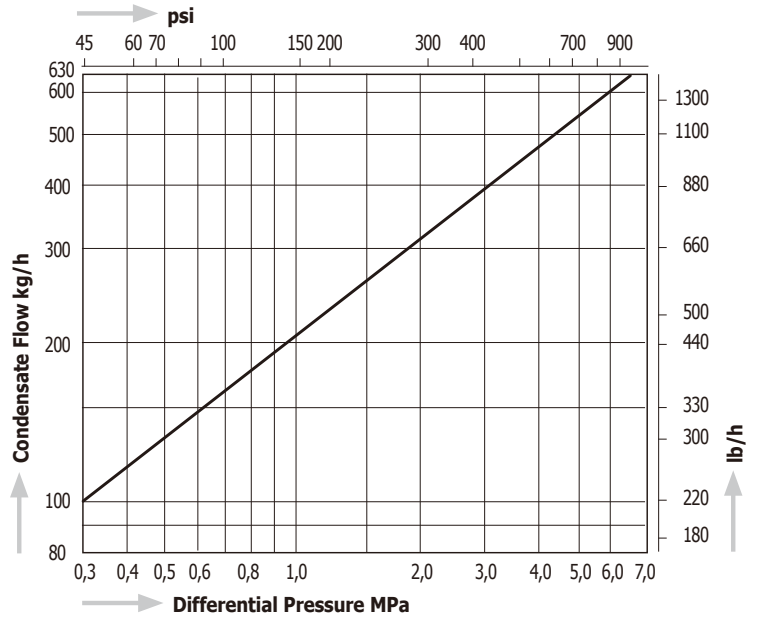

Dimensions

**S61N, S62N,
S61NW, S62NW**

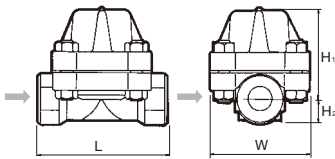

S61NF, S62NF

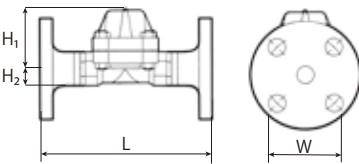

Table 1: Dimensions L and Weight

Model	Size	JIS 20K				JIS 30K				JIS 40K				JIS 63 K			
		mm	in	kg	lb	mm	in	kg	lb	mm	in	kg	lb	mm	in	kg	lb
S61NF S62NF	½"	200	7.9	7,3	16.1	200	7.9	8,4	18.5	200	7.9	8,7	19.2	220	8.7	9,6	21.2
	¾"	210	8.3	7,7	17.0	210	8.3	8,9	19.6	210	8.3	9,2	20.3	230	9.1	11,1	24.5
	1"	240	9.4	9,2	20.3	240	9.4	10,1	22.3	240	9.4	10,5	23.1	240	9.4	12,1	26.7

Model	Size	ASME Class 150				ASME Class 300				ASME Class 600				ASME Class 900			
		mm	in	kg	lb	mm	in	kg	lb	mm	in	kg	lb	mm	in	kg	lb
S61NF S62NF	½"	200	7.9	6,7	14.8	200	7.9	7,2	15.9	200	7.9	7,3	16.1	220	8.7	9,6	21.2
	¾"	210	8.3	7,7	17.1	210	8.3	8,2	18.1	210	8.3	8,5	18.7	230	9.1	10,9	24.0
	1"	240	9.4	8,3	19.1	240	9.4	9,4	20.7	240	9.4	9,6	21.2	240	9.4	13,3	29.3

Model	Size	DIN PN63				DIN PN100			
		mm	in	kg	lb	mm	in	kg	lb
S61NF S62NF	DN15	210	8.3	9,4	20.7	210	8.3	9,4	20.7
	DN20	230	9.1	11,4	25.1	230	9.1	11,4	25.1
				12,5	27.6			12,5	27.6

Model	Connections	Size	Max. Operating Pressure		Max. Operating Temperature		Dimensions (mm)				Dimensions (in)				Body Material	Weight		
			MPa	psig	°C	°F	L	H1	H2	W	L	H1	H2	W		kg	lb	
S61N (S62N)	Screwed Rc, NPT	½"	6,5	943	425 (S62N: 475)	800 (S62N: 887)	130	Table 1	90	25	100	Table 1	3.5	1.0	3.9	Forged Steel A105 (S62N: A182F22)	5,7	12.6
		¾"															Table 1	Table 1
		1"															Table 1	Table 1
S61NF (S62NF)	Flanged JIS, ASME, DIN	½"	6,5	943	425 (S62N: 475)	800 (S62N: 887)	130	Table 1	90	25	100	Table 1	3.5	1.0	3.9	Forged Steel A105 (S62N: A182F22)	5,7	12.6
		¾"															Table 1	Table 1
		1"															Table 1	Table 1
S61NW (S62NW)	Socket Weld JIS, ASME, DIN	½"	6,5	943	425 (S62N: 475)	800 (S62N: 887)	130	Table 1	90	25	100	Table 1	3.5	1.0	3.9	Forged Steel A105 (S62N: A182F22)	5,7	12.6
		¾"															Table 1	Table 1
		1"															Table 1	Table 1

SC31

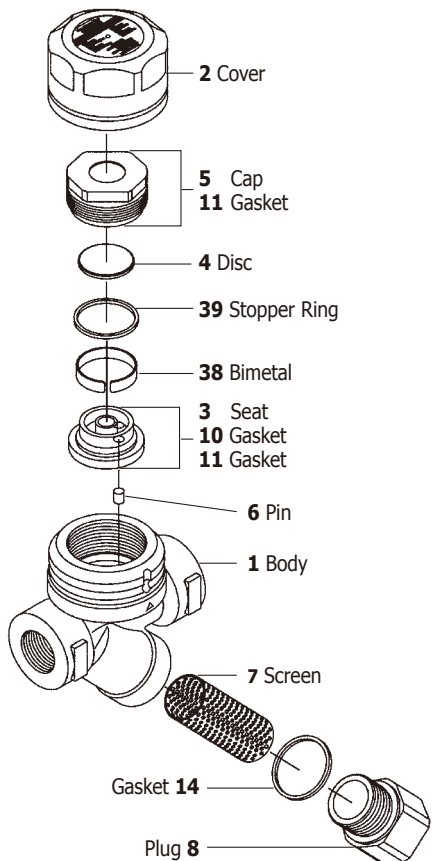

S31N (1/2"-1")

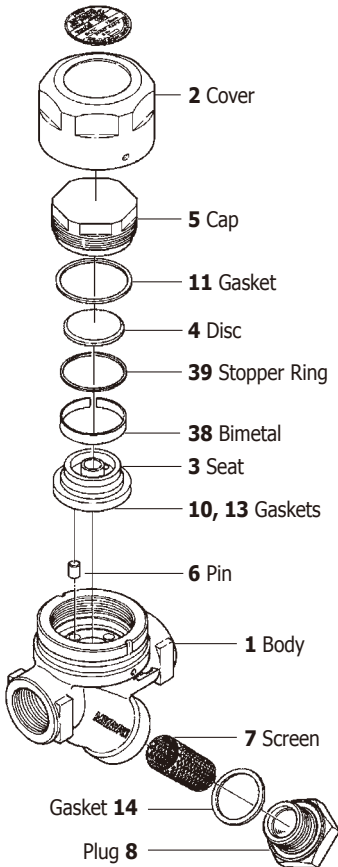

S31N (1 1/4"-2"), SC, SF (3/4"-1")

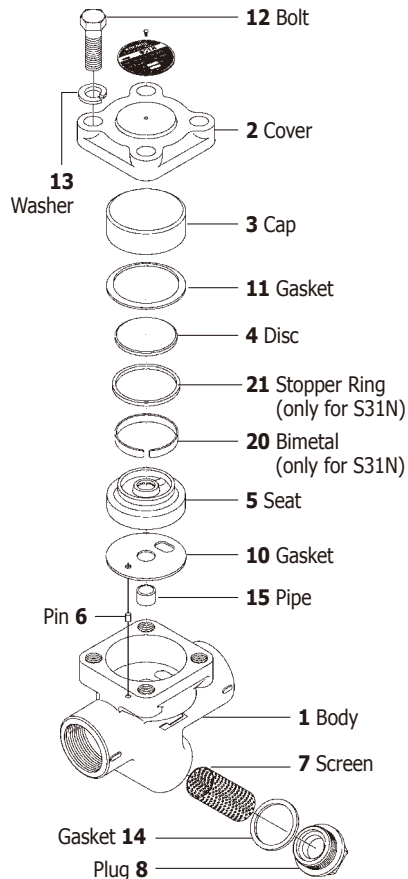

S55N/S55H

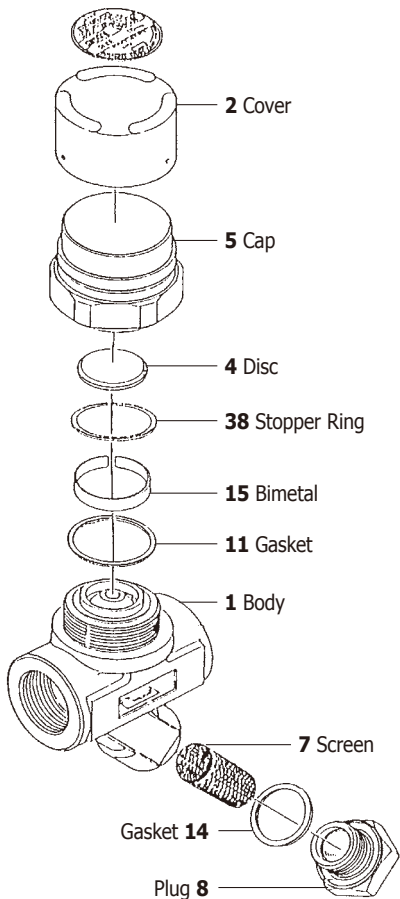

SU2N/SU2H

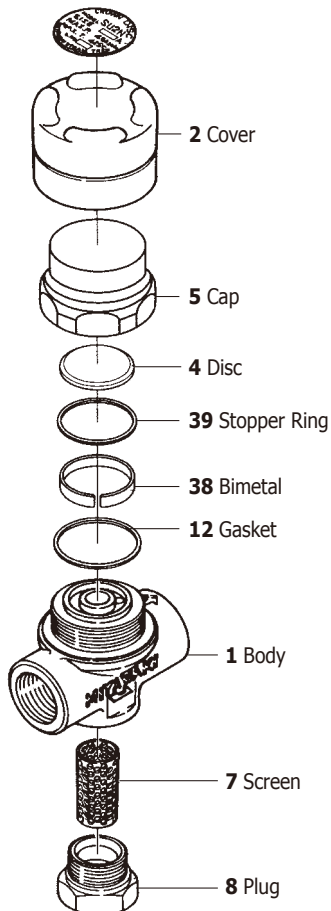

S61N/S62N

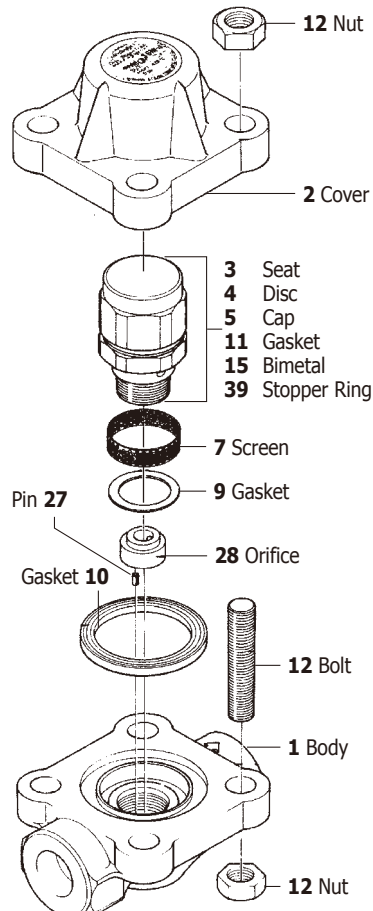

SV1

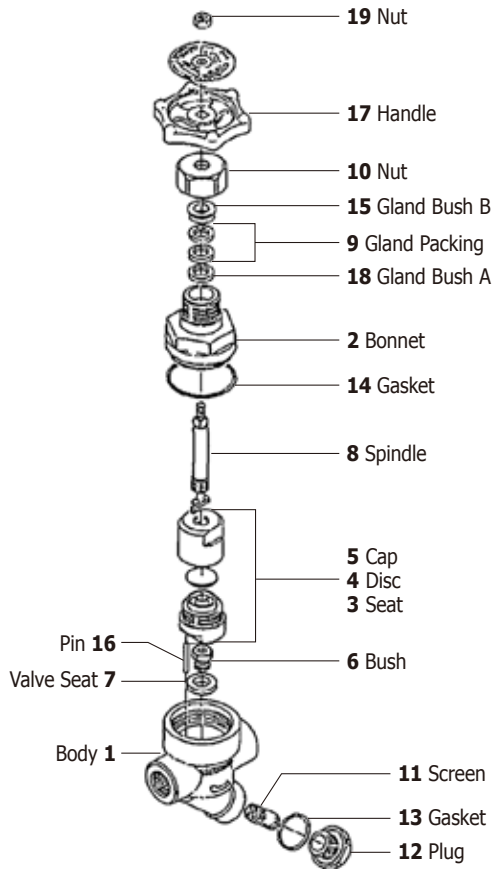

SV-N

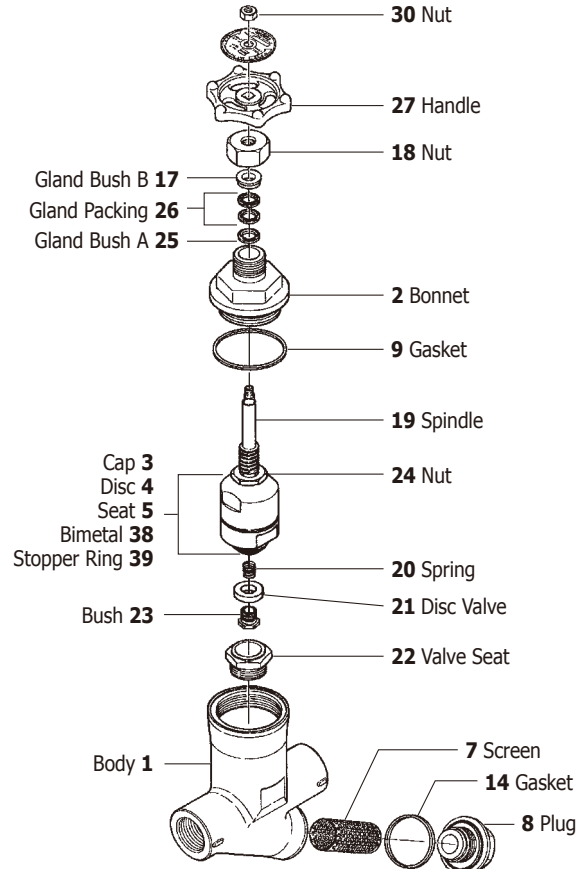

SL3

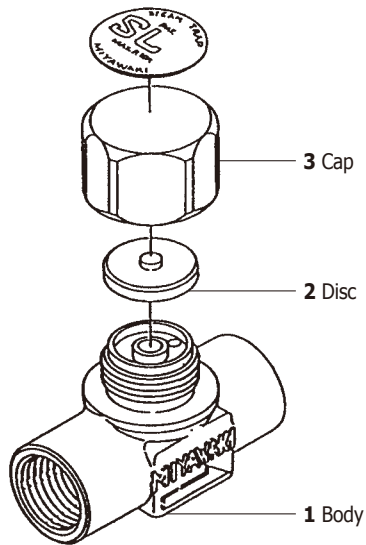

SD1

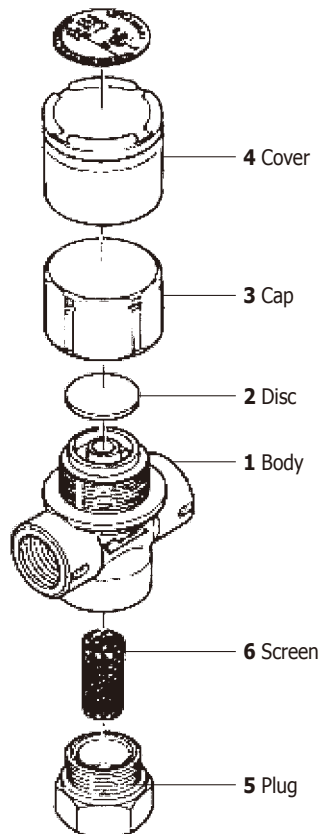

Inverted Bucket Steam Traps

SERIES E

Inverted Bucket Steam Traps belong to the family of mechanical traps. They operate on the difference in density between steam and water. MIYAWAKI offers a very wide range of inverted bucket steam traps for small up to large condensate loads. Inverted bucket steam traps discharge the condensate intermittently.

Models ER	Cast Iron Inverted Bucket Steam Traps for medium up to high condensate loads
ES	Cast Iron Inverted Bucket Steam Traps for small up to medium condensate loads
ESH, ER25	Cast Steel Inverted Bucket Steam Traps for high pressure and small up to high condensate loads
ESU	Stainless Steel Inverted Bucket Steam Traps for small up to medium condensate loads

Features

- All traps are equipped with stainless steel wear and corrosion resistant lever, valve and seat system for long and troubleless life.
- All valves and seats are lapped together.
- Traps of the series E contain the patented SCCV® (Self Closing and Centering Valve) – System, which increases the lifetime of the valve and seat substantially.
- A small hole in the top of the bucket secures continuous automatic air venting.
- All traps are designed for quick and easy inline repairability.
- Withstands high back pressure (up to 90%).

Application

Heat exchangers, dryers, unit heaters, sterilizers and other applications, where condensate must be removed immediately

Super-Discharger

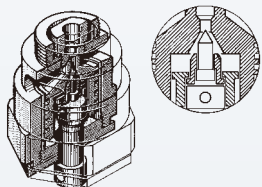

1. Incorporates the **MIYAWAKI SCCV®**-System (see pages 94 – 95)
2. Double valve system with needle pilot valve and main valve (for ER Type)
3. Operates by the pressure difference inside the valve unit
4. Makes the discharge capacity very large
5. Designed for high pressure up to 6,4 MPa (925 psig) – only for ER25

Operating principle

■ cold condensate
 ■ hot condensate
 ■ steam

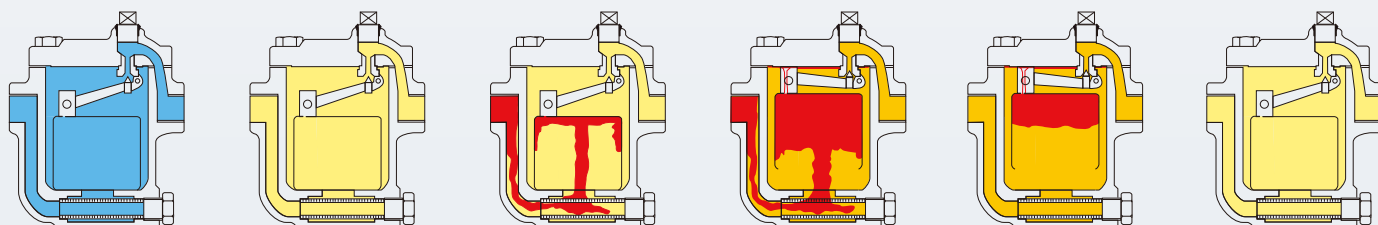

1 & 2

3 & 4

5 & 6

On start-up the bucket is down and the valve is open. Low temperature condensate and air, later high temperature condensate enter the trap. The condensate fills the bucket and the trap body completely. As the bucket is completely submerged in the water, it lies on the bottom of the trap, the valve is wide open and condensate will discharge.

Steam enters the trap under the bottom of the bucket. The more steam is entering the trap, the more it collects at the top of the bucket, causing the bucket to move upwards (buoyancy of the bucket inside the water). At the top position of the bucket the valve will close the seat.

Air and gases pass through a small hole in the top of the bucket and collect at the top of the trap. Steam is also passing through the hole and condensing. When more condensate is entering the trap, the bucket will lose its buoyancy and will move down. The valve will open and condensate will discharge.

ER

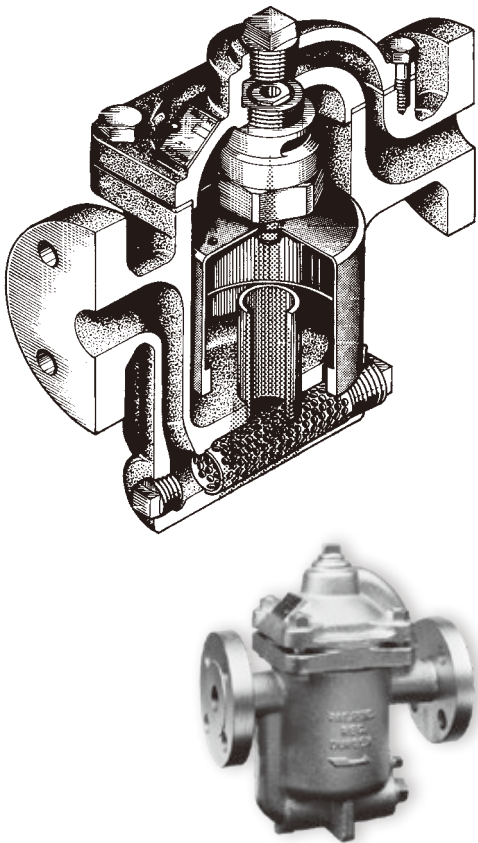

Capacity Chart ER

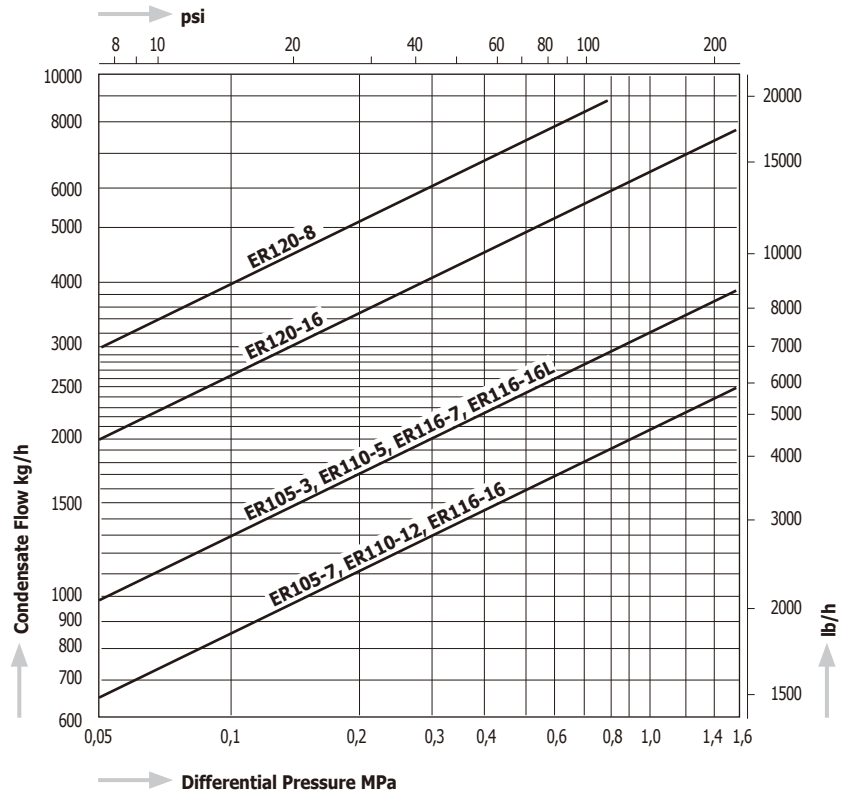

Dimensions

ER105

ER105F, ER110, ER116, ER120

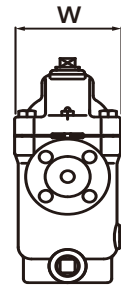
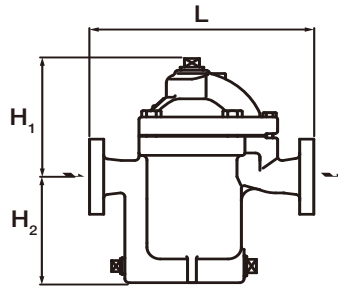
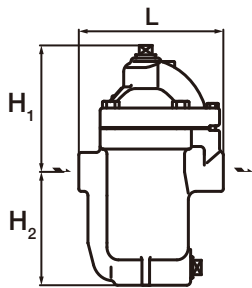

Model	Connections	Size	Max. Operating Pressure		Max. Operating Temperature		Dimensions (mm)				Dimensions (in)				Body Material	Weight														
			MPa	psig	°C	°F	L	H ₁	H ₂	w	L	H ₁	H ₂	w		kg	lb													
ER105 - 3 7	Screwed Rc, NPT	¾" - 1½"	0,3	43	220	428	190	155	134	120	7.5	6.1	5.3	4.7	Cast Iron FC250	10,2	22.5													
			0,7	100																										
ER105F - 3 7	Flanged JIS, ASME, DIN	½" - 1" 1¼" - 2"	0,3	43														254	155	134	120	10.0 10.2	6.1	5.3	4.7	13,6 15,1	29,9 33,2			
			0,7	100																										
			ER110 - 5 12	Flanged JIS, ASME, DIN			½" - 1" 1¼" - 2"	0,5	73	254	200	140	120	10.0 11.0		7.9	5.1											4.7	16,1 18,1	35,4 39,9
								1,2	174																					
ER116 - 7 16	Flanged JIS, ASME, DIN	½" - 1" 1¼" - 2"						0,7	100									300	230	132	190	11.8	9.1	5.2	7.5	19,0 23,0	41,8 50,7			
								1,6	230																					
			ER120 - 8 16	Flanged JIS, ASME, DIN			1½" - 2½"	0,8	116	400	220	217	235	15.8		8.7	8.5											9.3	46,0	101,4
								1,6	230																					

ER25

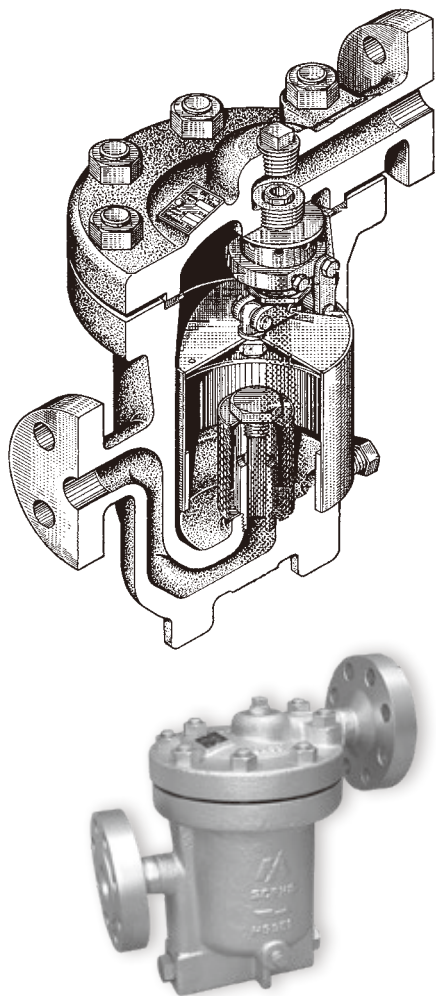

Capacity Chart ER25

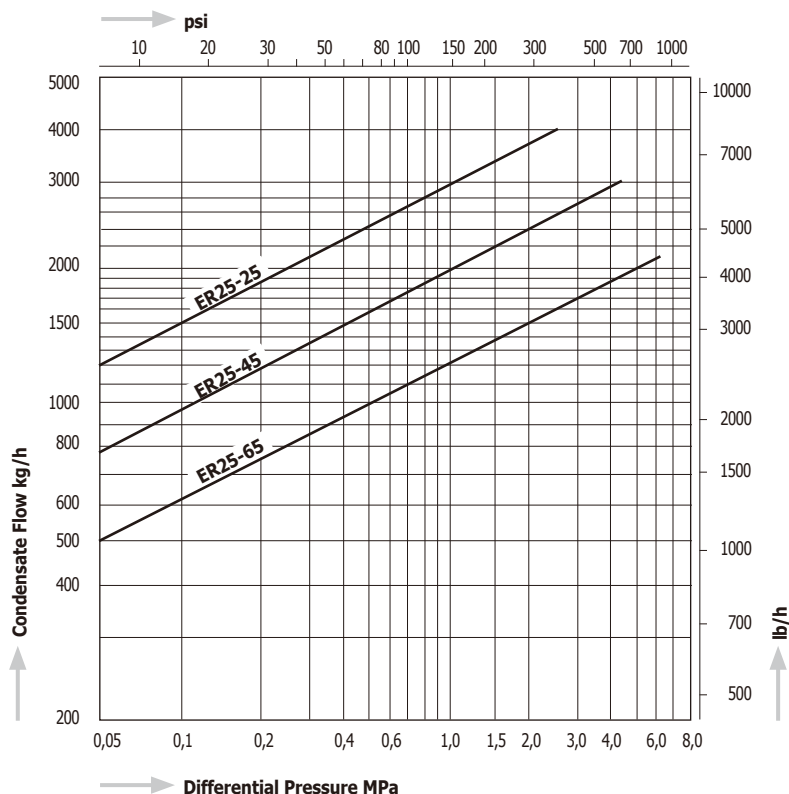

Dimensions ER25

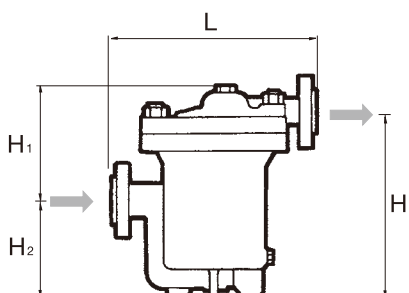

* Available options ER25

Max. operating temperature 470°C (878°F)
with body material WC6

Table 1: Dimensions

Size	Flange Standards			L (mm)	L (in)
	JIS 10 - 40 K	ASME 150 lb / 300 lb RF	DIN PN40		
½" - 1" (DN15 - 25)	JIS 10 - 40 K	ASME 150 lb / 300 lb RF	DIN PN40	340	13.4
	ASME 600 lb RF	ASME 150 - 600 lb RJ	DIN PN63 / PN100 (DN15 / DN20)	345	13.6
	JIS 63 K	ASME 900 lb RF / RJ	DIN PN63 / PN100 (DN25)	380	15.0
1¼" - 2" (DN32 - 50)	JIS 10 - 40 K	ASME 150 - 600 lb RF / RJ	-	380	15.0
	JIS 63 K	ASME 900 lb RF / RJ	DIN PN40 / PN63 / PN100	400	15.8

Model	Connections	Size	Max. Operating Pressure		Max. Operating Temperature		Dimensions (mm)				Dimensions (in)				Body Material	Weight	
			MPa	psig	°C	°F	L	H ₁	H ₂	H ₃	L	H ₁	H ₂	H ₃		kg	lb
ER25 -	Flanged JIS, ASME, DIN	½" - 2"	2,5	360	425*	800	Table 1	210	180	345	Table 1	8.3	7.1	13.6	Cast Steel SCPH2	½" - 1"	112.4
			4,4	640												1¼" - 2"	
			6,4	925												58	
ER25W -	Socket Weld JIS, ASME, DIN	½" - 2"	2,5	360	425*	800	½" - 1½" 340	210	180	345	½" - 1½" 13.4	8.3	7.1	13.6	Cast Steel SCPH2	½" - 1½"	105.6
			4,4	640												48	
			6,4	925												2"	

Stainless Steel as body material is available as special design. For more details, please contact MIYAWAKI Inc. or an authorized representative.

ES

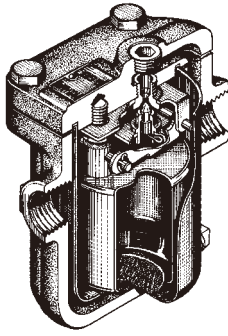

Dimensions

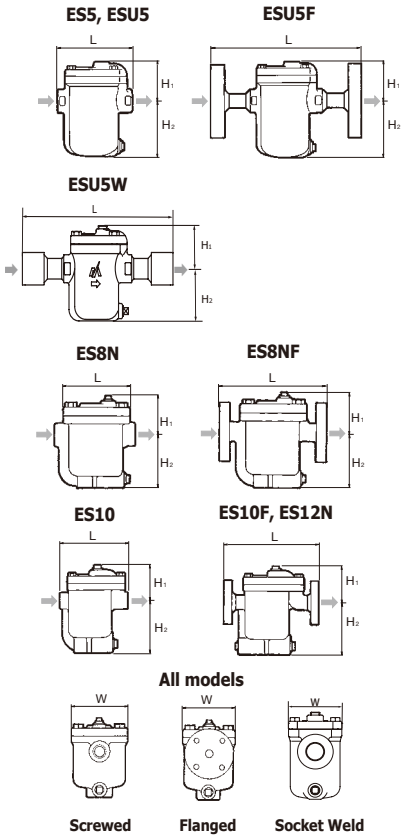

Available options

Depending on the Maximum Operating Pressure the following models are available:

Model	Max. Operating Pressure	
	MPa	psig
ES5 - 3	0,3	43
ES5 - 7	0,7	100
ES5 - 11	1,1	160
ES5 - 16	1,6	230
ESU5 - 3	0,3	43
ESU5 - 7	0,7	100
ESU5 - 11	1,1	160
ESU5 - 16	1,6	230
ESU5 - 21	2,1	305
ES8N - 5	0,5	73
ES8N - 8	0,8	116
ES8N - 16	1,6	230
ES10 - 8	0,8	116
ES10 - 12	1,2	174
ES10 - 16	1,6	230

Capacity Chart ES

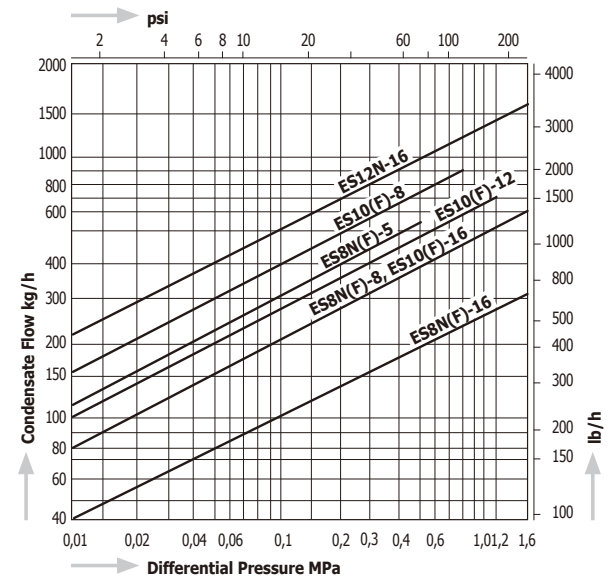
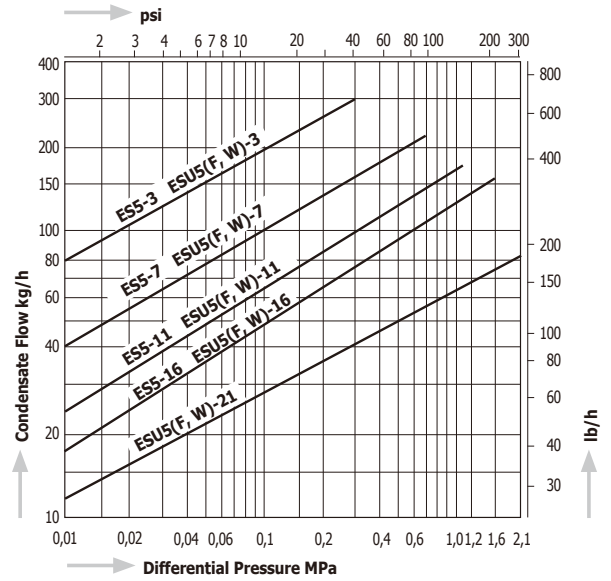

Model	Connections	Size	Max. Operating Pressure		Max. Operating Temperature		Dimensions (mm)				Dimensions (in)				Body Material	Weight	
			MPa	psig	°C	°F	L	H ₁	H ₂	W	L	H ₁	H ₂	W		kg	lb
ES5	Screwed Rc, NPT	1/2"	1,6	230	350	662	103	59	67	75	4.1	2.3	2.6	3.0	Ductile Cast Iron FCD450	1,9	4.2
		3/4"					105	57	69		4.1	2.2	2.7			1,9	4.2
		1"					109	57	69		4.3	2.2	2.7			2,1	4.6
ESU5	Screwed Rc, NPT	1/2"	2,1	305	350	662	103	57	69	75	4.1	2.2	2.7	3.0	Stainless Steel SCS13A	1,9	4.2
		3/4"					105				4.1					2,0	4.4
		1"					109				4.3					2,1	4.6
ESU5F	Flanged JIS, ASME, DIN	1/2"	2,1	305	350	662	175	57	69	75	6.9	2.2	2.7	3.0	Stainless Steel SCS13A	3,5	7.7
		3/4"					195				7.7					3,7	8.2
		1"					215				8.5					4,1	9.0
ESU5W	Socket Weld JIS, ASME, DIN	1/2"	2,1	305	350	662	203	57	69	75	8.0	2.2	2.7	3.0	Stainless Steel SCS13A	2,5	5.5
		3/4"					230				9.1					2,6	5.7
		1"					254				10.0					2,8	6.2
ES8N	Screwed Rc, NPT	1/2"	1,6	230	350	662	130	73	90	100	5.1	2.9	3.5	3.9	Ductile Cast Iron FCD450	3,7	8.2
		3/4"					135				5.3					3,9	8.6
		1"					175				6.9					5,3	11.7
ES8NF	Flanged JIS, ASME, DIN	1/2"	1,6	230	350	662	195	68	95	100	7.7	2.7	3.7	3.9	Ductile Cast Iron FCD450	5,7	12.5
		3/4"					215				8.5					6,8	15.0
		1"					215				8.5					6,8	15.0
ES10	Screwed Rc, NPT	3/4" - 1 1/2"	1,6	230	220	428	190	102	134	120	7.5	4.0	5.3	4.7	Cast Iron FC250	9,3	20.5
		1/2" - 1"					254				10.2					12,7	28.0
		1 1/4" - 2"					260				10.2					14,2	31.3
ES10F	Flanged JIS, ASME, DIN	1/2" - 1"	1,6	230	220	428	270	140	140	120	10.6	5.5	5.5	4.7	Cast Iron FC250	13,5	29.7
		1 1/4" - 2"					280				11.0					15,1	33.2
		1 1/4" - 2"					280				11.0					15,1	33.2

ESH

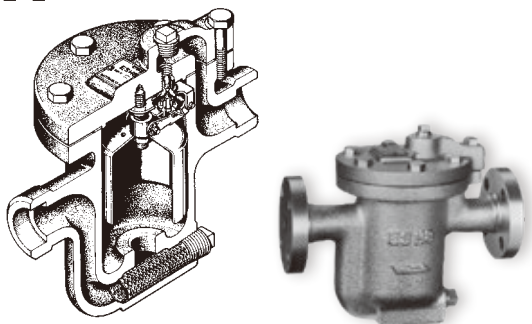

Dimensions

ESH8N, ESH8NW

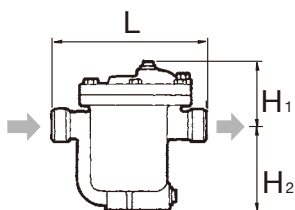

ESH8NF

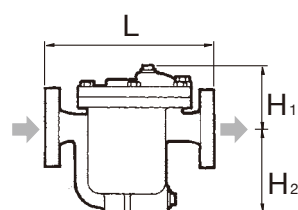

ESH21W

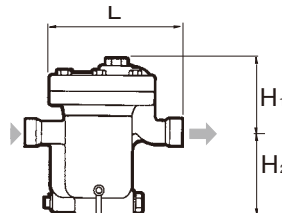

ESH21F

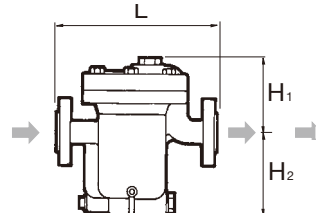

Capacity Chart ESH

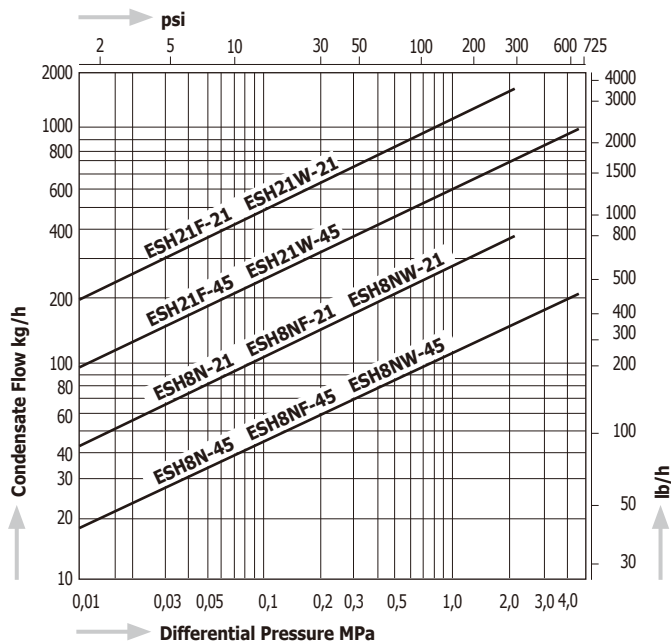

All models

Screwed, Socket Weld

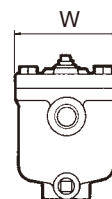

Flanged

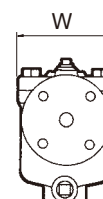

Table 1: weights

Size	Weight (kg)									Weight (lb)								
	JIS (FF, RF)		JIS (RF)		ASME/JPI (RF)			DIN		JIS (FF, RF)		JIS (RF)		ASME/JPI (RF)			DIN	
	10K, 16K	20K	30K	40K	150lb	300lb	600lb	PN40	PN100	10K, 16K	20K	30K	40K	150lb	300lb	600lb	PN40	PN100
1/2 "	11,0	11,0	12,4	12,8	11,4	12,1	12,1	11,3	12,2	24.2	24.2	27.3	28.2	25.1	26.6	26.6	24.9	26.9
3/4 "	12,4	12,4	13,7	14,0	11,8	12,8	13,2	12,9	15,0	27.3	27.3	30.2	30.8	26.0	28.2	29.1	28.4	33.0
1 "	13,2	13,6	14,6	15,0	12,4	13,6	14,0	15,0	18,3	29.1	29.9	32.1	33.0	27.3	29.9	30.8	33.0	40.3

Model	Connections	Size	Max. Operating Pressure		Max. Operating Temperature		Dimensions (mm)				Dimensions (in)				Body Material	Weight	
			MPa	psig	°C	°F	L	H ₁	H ₂	W	L	H ₁	H ₂	W		kg	lb
			ESH8N - 21 45	Screwed Rc, NPT	1/2" - 1"	2,1	305	400	752	1/2" - 3/4" = 220 1" = 224	114	111	146	1/2" - 3/4" = 8.7 1" = 8.8		4.5	4.4
ESH8NF - 21 45	Flanged JIS, ASME, DIN	2,1	305			250	114								111		
ESH8NW - 21 45		Socket Weld JIS, ASME, DIN	2,1	305	220	114	111			146	8.7	4.5	4.4	5.7	11,0	24.2	
ESH21F - 21 45	Flanged JIS, ASME, DIN		2,1	305	350	145	160			205	13.8	5.7	6.3	8.1	31,0	68.3	
ESH21W - 21 45		Socket Weld JIS, ASME, DIN	2,1	305	300	145	160			205	11.8	5.7	6.3	8.1	28,0	61.7	

Stainless Steel as body material is available as special design. For more details, please contact MIYAWAKI Inc. or an authorized representative.

ES5/ESU5

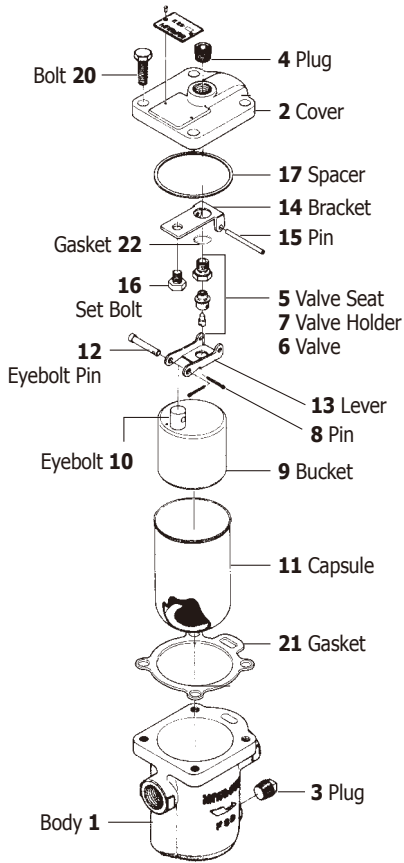

ES8N

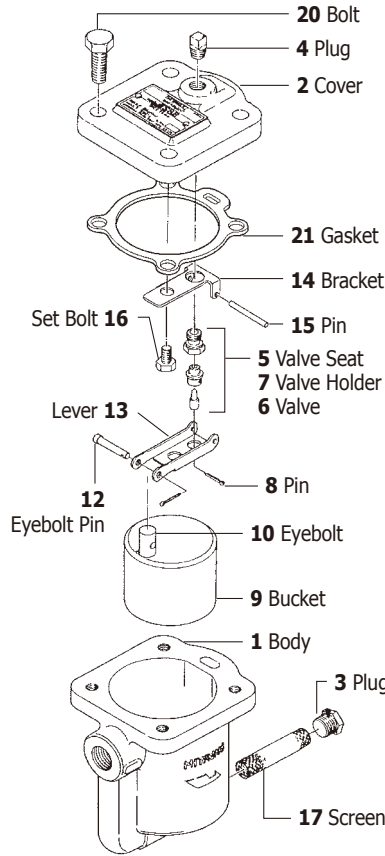

ES10

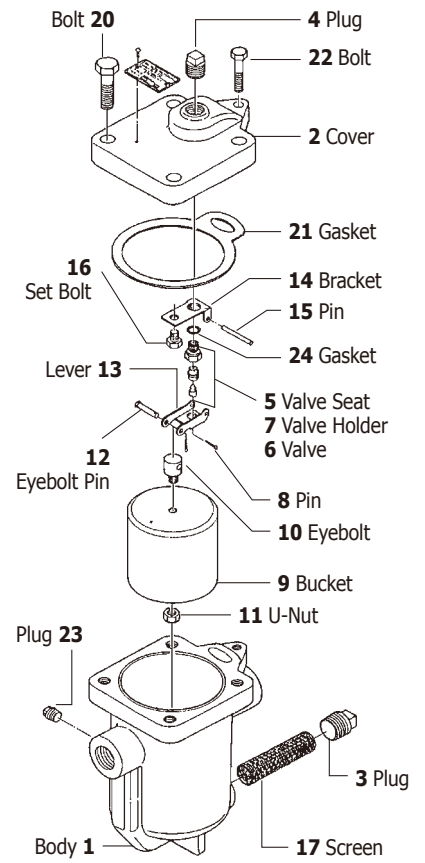

ES12N

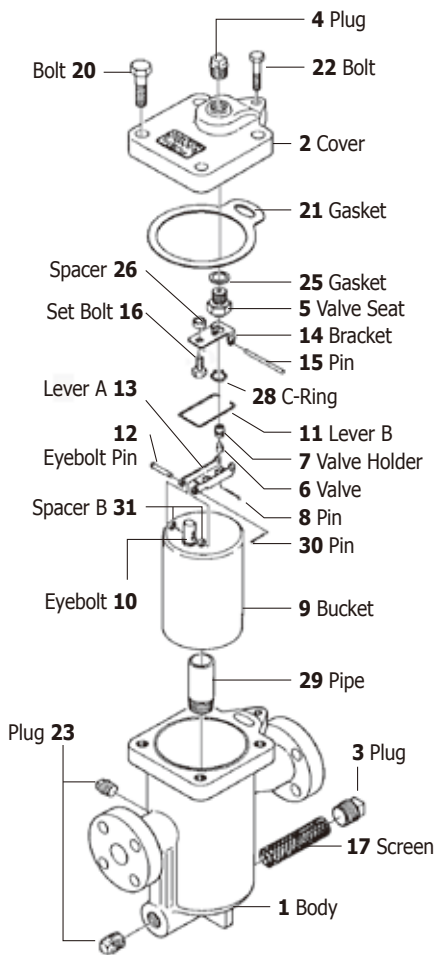

ER105/110/116

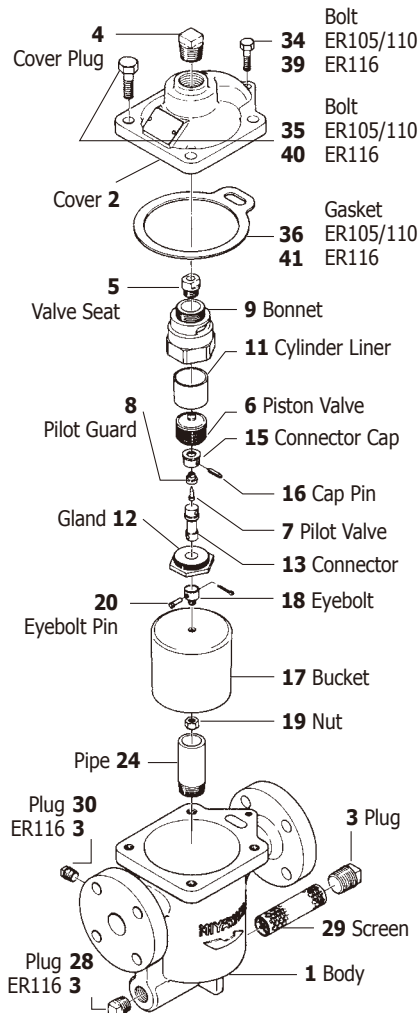

ER120

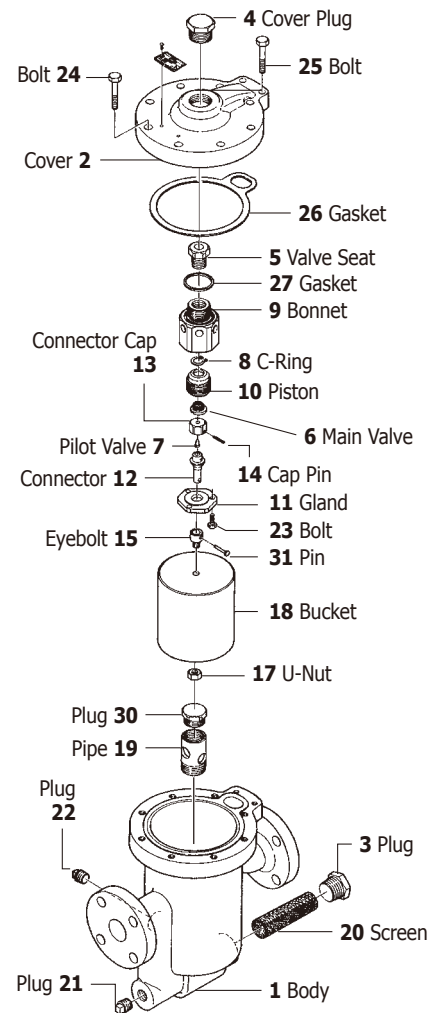

ESH8N

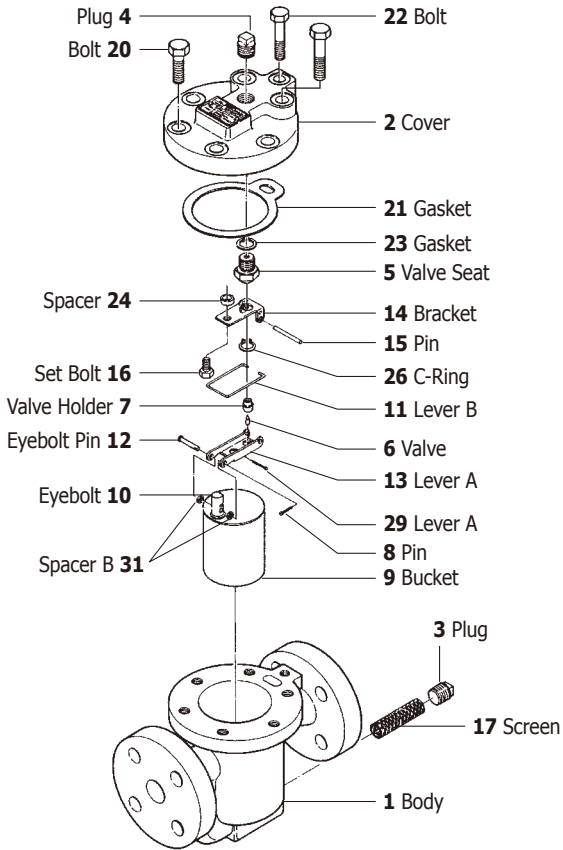

ESH21

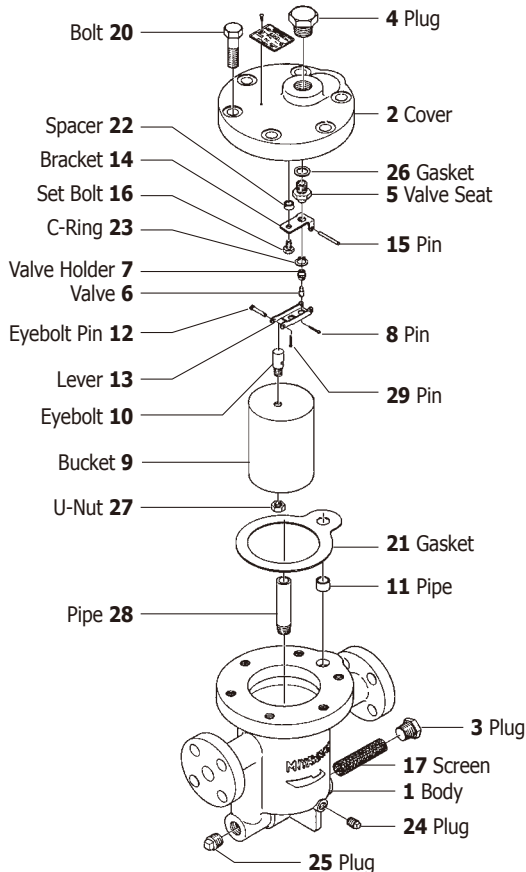

ER25

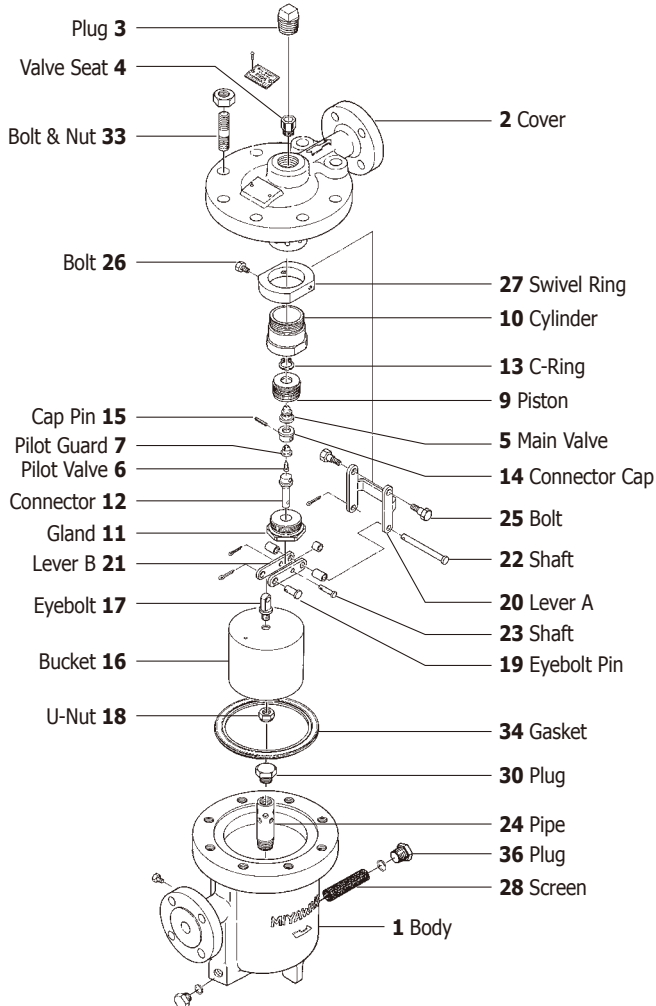

Ball Float Steam Traps

SERIES G

Ball Float Steam Traps belong to the family of mechanical traps. They operate on the difference in density between steam and water. A ball float is connected with a lever to the valve and seat or it is floating freely inside the valve body. Condensate will be discharged once it reaches a certain level inside the trap. Condensate is discharged continuously.

Models	G11N, G12N	Cast Iron Steam Traps for small and medium condensate loads
	G15N	Cast Iron Steam Trap for low pressure and large condensate loads
	G3N, G5	Ductile Cast Iron Steam Traps for large condensate loads
	G2-G8	Cast Iron Steam Traps for large condensate loads
	G20N, G30	Ductile Cast Iron Steam Trap for medium condensate loads
	GH3N, GH5, GH2-GH8, GH50, GH60, GH70	Cast Steel Steam Traps for large condensate loads
	GH40, GTH12, GTH10	Cast Steel Steam Traps for medium condensate loads
	GC1, GC1V	Stainless Steel Steam Traps for small condensate loads
	GC20	Stainless Steel Steam Trap for medium condensate loads

- Features**
- All traps are equipped with stainless steel wear and corrosion resistant float, lever, valve and seat systems for a long and problem free operation.
 - Each ball float steam trap is equipped with an air vent for venting air and gases at the time of start-up and during operation.
 - The large capacity steam traps like G2-G8, GH2-GH8 use a double ported balance valve system, which is small in its physical size compared with the very high capacity of the traps.
 - All traps are designed for quick and easy maintenance.

Application

Ball Float Steam Traps can be used in all process applications, like all kind of heat exchangers, tank and unit heaters and others, where condensate must be removed immediately after it forms.

The type GC1 is especially designed for applications in the food, pharmaceutical and other industries with small condensate loads and the need for stainless steel bodies. It can be also installed for drainage of steam main lines.

Operating principle

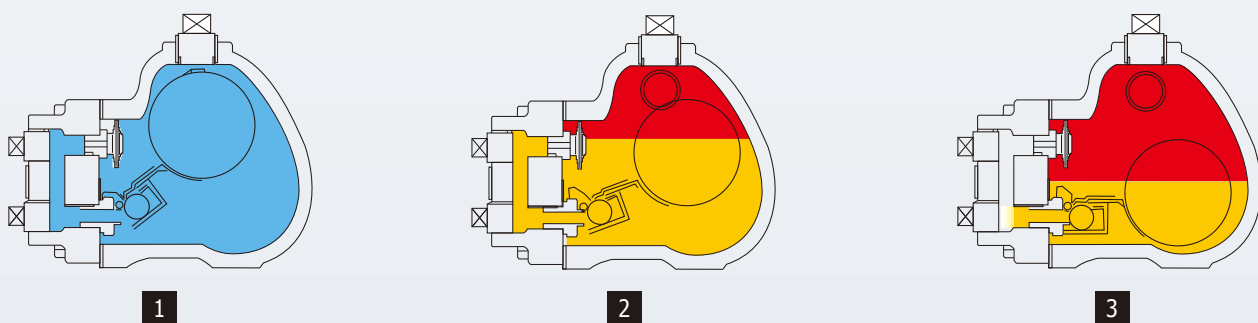

On start-up air is quickly discharged through the thermostatic air vent (membrane or bimetal type). Cold condensate fills the steam trap body. As soon as a certain water level is reached, the float rises and opens the valve. The cold condensate is discharged through the open valve and the open air vent.

When the condensate reaches saturation temperature, the air vent closes and condensate is discharged only through the main valve orifice. The condensate forms a water seal inside the trap body, which prevents live steam loss at all times.

The opening degree of the valve is regulated by the water level inside the trap body. Condensate is discharged continuously. As long as air enters the trap and accumulates at the top of the trap body, the temperature cools down a little bit and the air vent, which opens slightly below saturation temperature, begins to discharge the air from the trap.

G11N, G12N

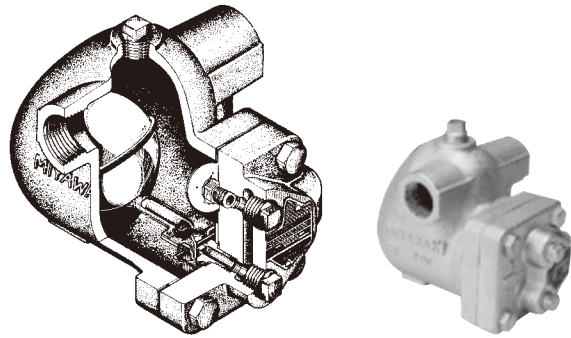

G15N

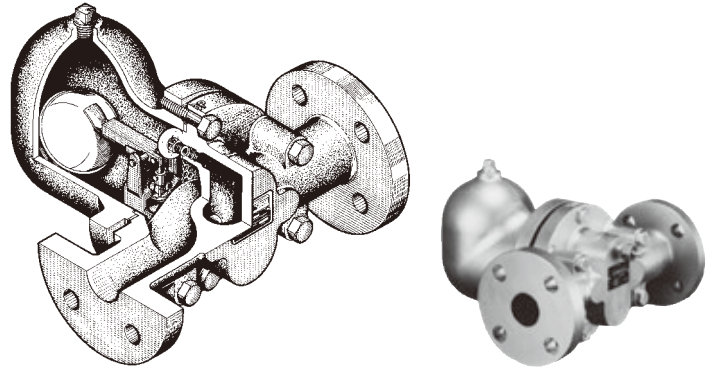

Capacity Chart G11N, G12N

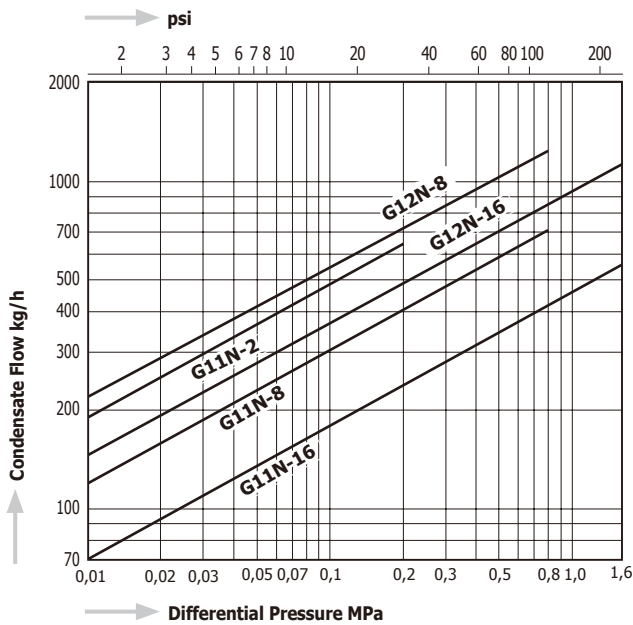

Capacity Chart G15N

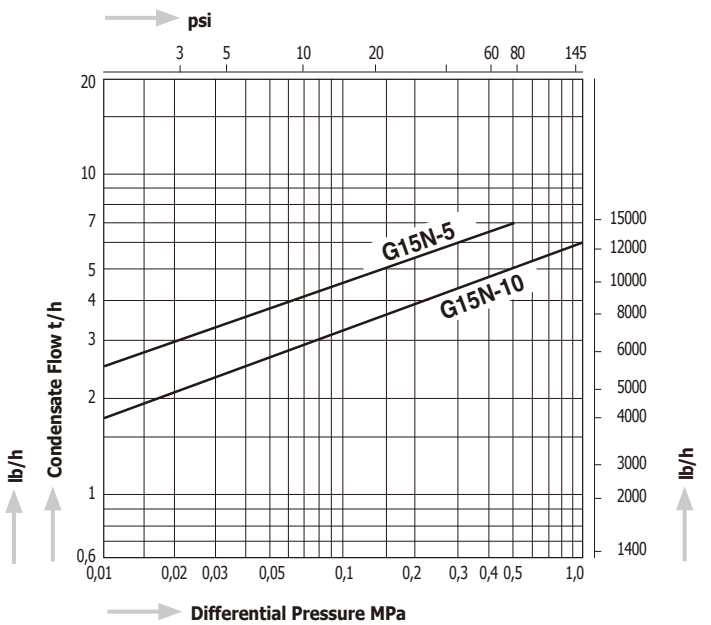

Dimensions G11N, G12N

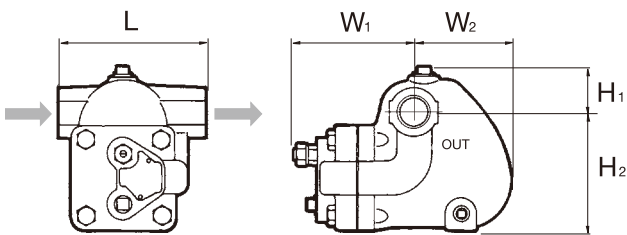

Dimensions G15N

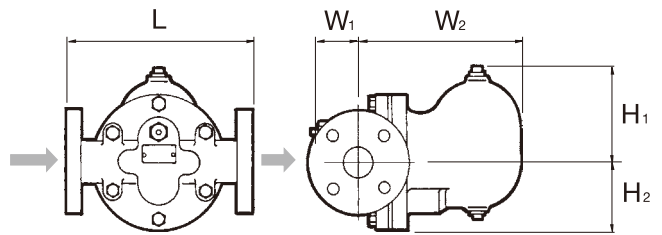

Model	Connections	Size	Max. Operating Pressure		Max. Operating Temperature		Dimensions (mm)					Dimensions (in)					Body Material	Weight			
			MPa	psig	°C	°F	L	H ₁	H ₂	W ₁	W ₂	L	H ₁	H ₂	W ₁	W ₂		kg	lb		
G11N - 2 8 16	Screwed Rc, NPT	½", ¾"	0,2	29	220	428	120	37	92	97	60	4.7	1.5	3.6	3.8	2.4	Cast Iron FC250	3,9	8.6		
			0,8	116																	
			1,6	230																	
G12N - 8 16	Screwed Rc, NPT	¾", 1"	0,8	116	220	428	140	47	113	102	92	5.5	1.9	4.4	4.0	3.6				6,0	13.2
			1,6	230																	
G15N - 5 10	Flanged JIS, ASME, DIN	1¼" - 2"	0,5	73	220	428	300	130	90	30	230	11.8	5.1	3.5	1.2	9.1				20,0	44.0
			1,0	145																	

For G11N and G12N, flanged connection is available as special design. Please contact MIYAWAKI Inc. or an authorized representative.

G20N

GC20

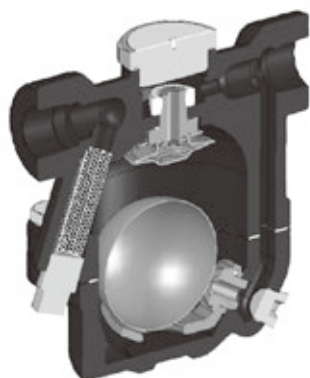

Screwed



Flanged Connection

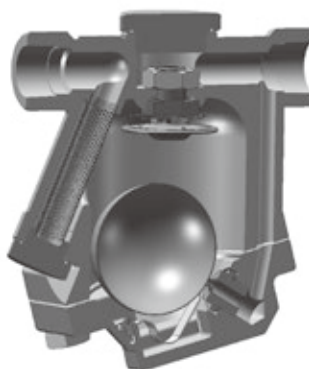

Screwed



Flanged Connection

Capacity Chart G20N / GC20

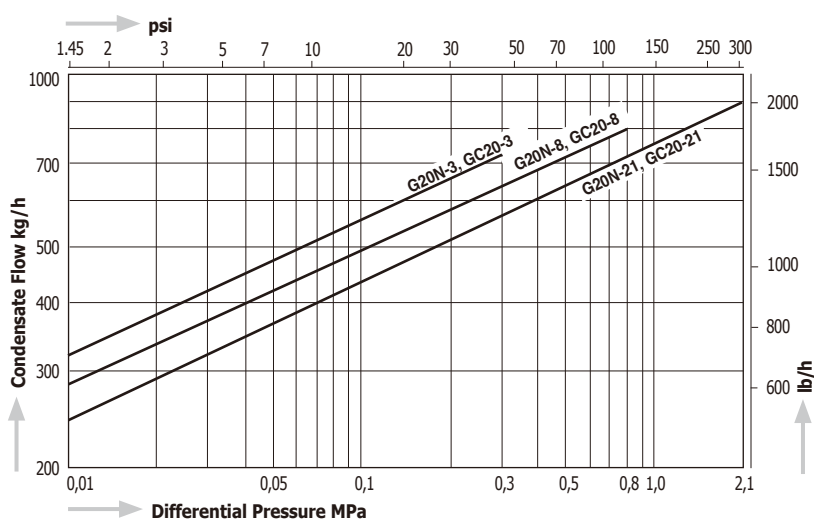

Dimensions G20N

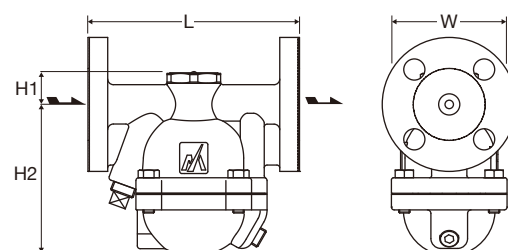

Dimensions GC20

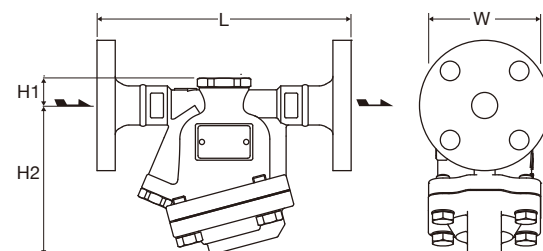

Available versions G20N / GC20

Max. Operating Pressure:

- G20N (GC20)- 3 0,3 MPa (43 psig)
- G20N (GC20)- 8 0,8 MPa (116 psig)
- G20N (GC20)- 21 2,1 MPa (305 psig)

Model	Connections	Size	Max. Operating Pressure, PMO		Max. Operating Temperature, TMO		Dimensions (mm)				Dimensions (in)				Body Material	Weight											
			MPa	psig	°C	°F	L	H ₁	H ₂	W	L	H ₁	H ₂	W		kg	lb										
G20N	Screwed Rc, NPT	1/2"	2,1	305	220	428	120	24	105	82	4.7	1.0	4.1	3.2	Ductile Cast Iron FCD450	2,5	5.5										
		3/4"							107				4.2			2,6	5.7										
		1"																									
G20NF	Flanged JIS, ASME	1/2"					2,1	305	220	428	150*	24	105	82		5.9	1.0	4.1	3.2	Ductile Cast Iron FCD450	3,8*	8.4*					
		3/4"									105		4.1					4,2*			9.2*						
		1"																									
	Flanged DIN	DN15									150	24	105	82		5.9	1.0	4.1	3.2		3,7	8.1					
		DN20									160*		6.3			4,2		9.2									
		DN25																									
GC20	Screwed Rc, NPT	1/2"					2,1	305	220	428	120	21	113	86		4.7	0.8	4.4	3.4	Stainless Steel SCS13A	2,4	5.3					
		3/4"																									
		1"																									
GC20F	Flanged JIS, ASME	1/2"	2,1	305	220	428					175	21	113	86	6.9	0.8	4.4	3.4	Stainless Steel SCS13A		3,9*	8.6*					
		3/4"									195		7.7		5,0*		11.0*										
		1"									215		8.5		5,8*		12.8*										
	Flanged DIN	DN15									150	21	113	86	5.9	0.8	4.4	3.4			3,4	7.5					
		DN20									160		6.3		3,9		8.6										
		DN25																									

*Depending on the flange rating, the weight and length may differ.

G30



Capacity Chart

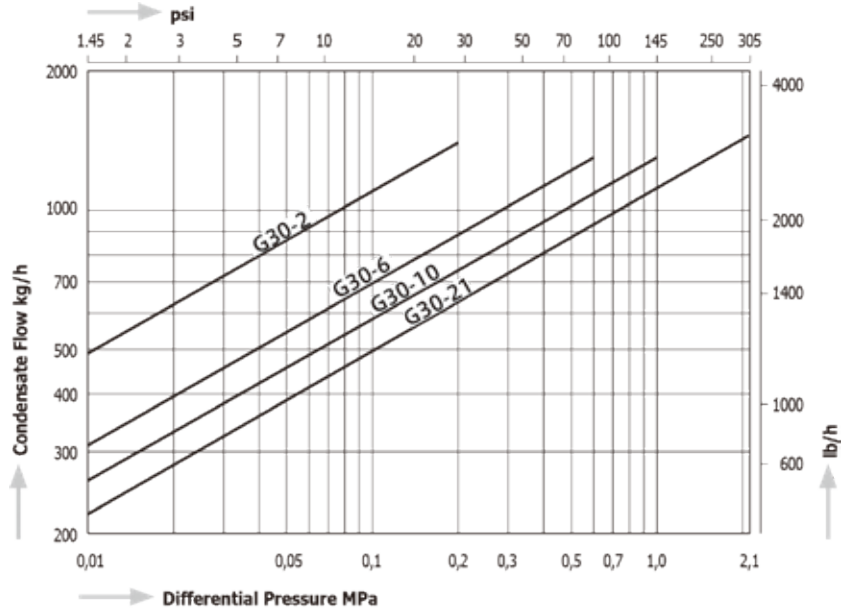

Dimensions

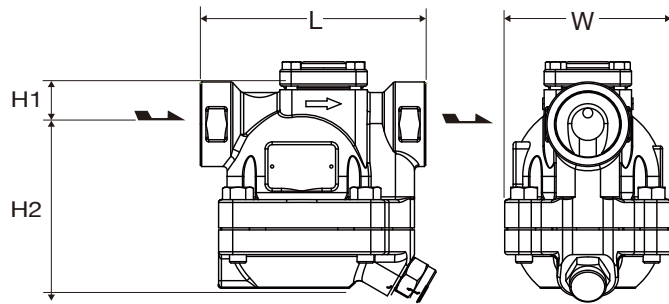

Connections	Size	Dimensions (mm)				Dimensions (in)				Weight	
		L	H1	H2	W	L	H1	H2	W	kg	lb
Rc	1"	155	44	125	118	6.1	1.7	4.9	4.6	6.5	14.3
	1-1/4"	160				6.3				6.5	14.3
	1-1/2"	160				6.3				6.3	13.9
NPT	1"	160	44	125	118	6.3	1.7	4.9	4.6	6.6	14.5
	1-1/4"	165				6.5				6.5	14.3
	1-1/2"	165				6.3				6.3	13.9

Model	Max. Allowable Pressure (PMA)		Max. Allowable Temperature (TMA)		Max. Operating Pressure (PMO)		Max. Operating Temperature (TMO)		Body Material
	MPa	psig	°C	°F	MPa	psig	°C	°F	
G30-2	2.1	305	250	482	0.2	29	235	455	Ductile Cast Iron FCD450
G30-6					0.6	87			
G30-10					1	145			
G30-21					2.1	305			

G2, G4, G6, G8 GH2, GH4, GH6, GH8

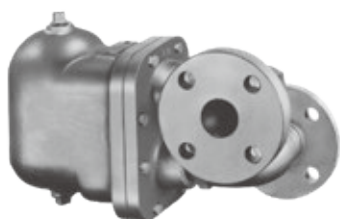
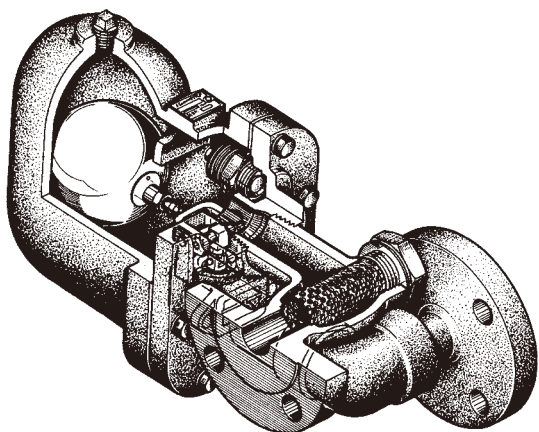

Capacity Chart

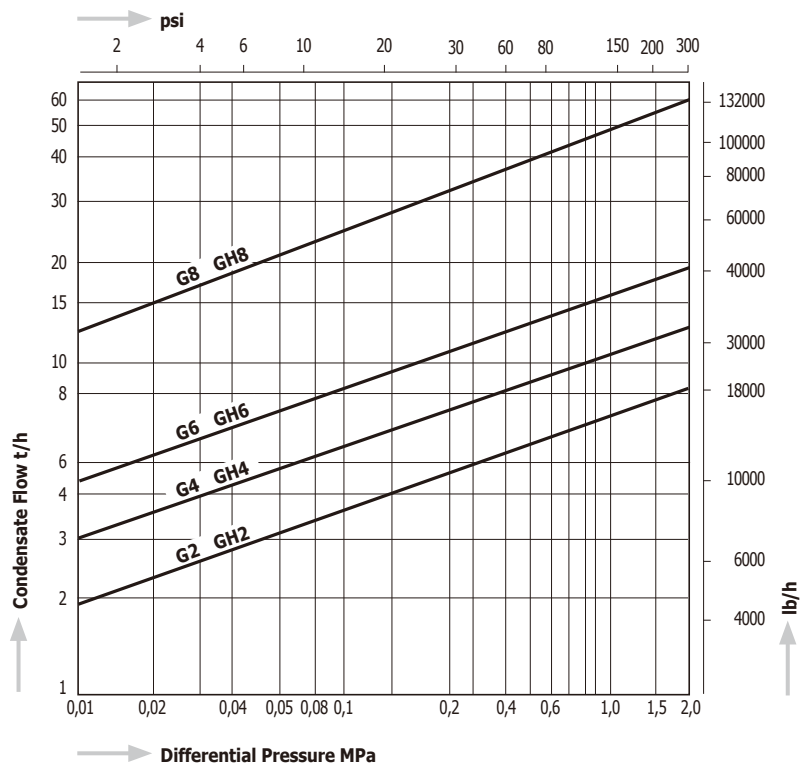

Dimensions

G2 / GH2

G4, G6, G8 / GH4, GH6, GH8

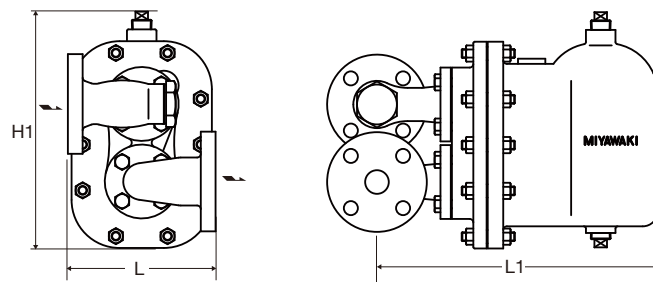
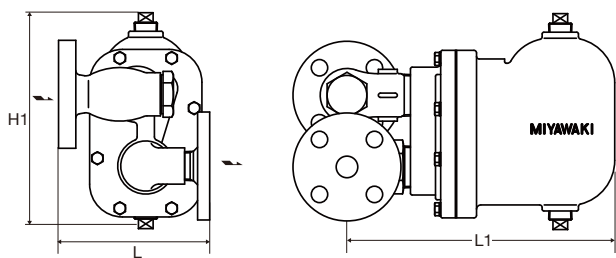

Model	Connections	Size	Max. Operating Pressure		Max. Operating Temperature		Dimensions (mm)			Dimensions (in)			Body Material	Weight						
			MPa	psig	°C	°F	L	L ₁	H	L	L ₁	H		kg	lb					
G2	Flanged JIS, ASME, DIN	1"	1,6	230	220	428	175	310	250	6.9	12.2	9.8	Cast Iron FC250	21	46.2					
		1 1/4"					7.1													
		1 1/2", 2"					7.5													
		1 3/4" - 2"					7.9													
G4		1 1/2" - 3"	10.6	16.1	13.8	62	136.4													
G6		3", 4"	13.8	22.4	19.9			147	323.4											
GH2		1" - 1 1/2"	2,0	290	400					752	200	310		235	7.9	12.2	9.1	Cast Steel SCPH2	24	52.8
		2"									8.3									
GH4	1 1/4" - 2"	7.9	14.9	12.6	43	94.6														
GH6	1 1/2" - 3"	10.6	16.3	13.6			68	149.6												
GH8	3", 4"	13.8	23.2	18.5	162	356.4														

G3N, G5 GH3N, GH5

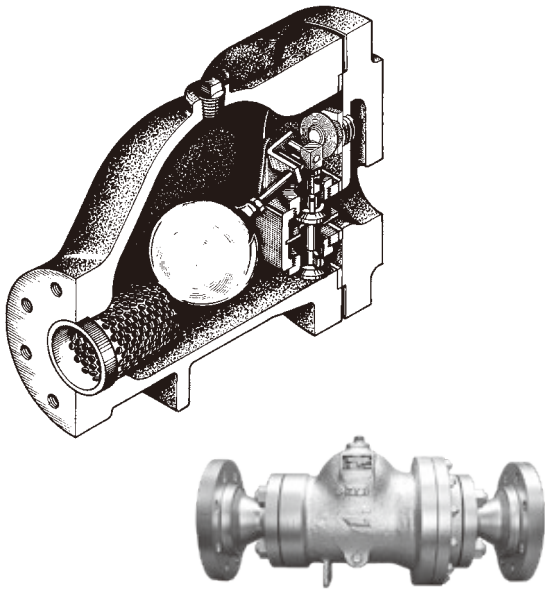

Dimensions G3N-R, G5-R, GH3N-R, GH5-R

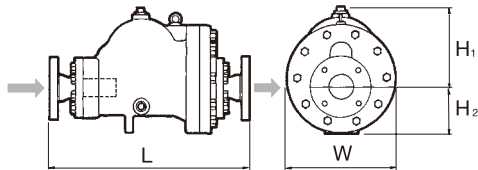

Capacity Chart

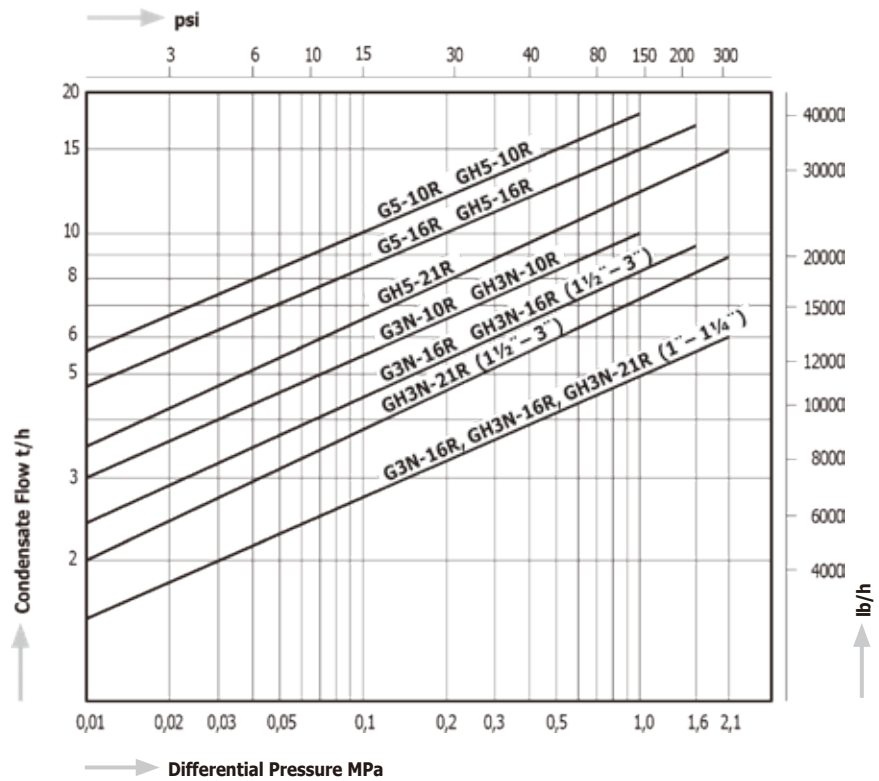

Table 1: Dimensions (ASME and DIN)

Model	Flange Standards		Size	L (mm)	L (in)	
G3N-R	DIN PN16	ASME 150 lb / 300 lb RF	DN25 - DN40	1" - 1½"	437	17.2
			DN50	2"	467	18.4
			DN60, DN80	2½", 3"	497	19.6
GH3N-R	DIN PN40	ASME 150 lb / 300 lb RF	DN25, DN32	1", 1¼"	457	18.0
			DN40	1½"	477	18.8
			DN50	2"	487	19.2
			DN65, DN80	2½", 3"	517	20.4

Model	Flange Standards		Size	L (mm)	L (in)	
G5-R	DIN PN16	ASME 150 lb / 300 lb RF	DN50	2"	540	21.3
			DN65, DN80	2½", 3"	570	22.4
			DN100	4"	600	23.6
GH5-R	DIN PN40	ASME 150 lb / 300 lb RF	DN50	2"	550	21.7
			DN65, DN80	2½", 3"	580	22.8
			DN100	4"	620	24.4

Model	Connections	Size	Max. Operating Pressure		Max. Operating Temperature		Dimensions (mm)				Dimensions (in)			Body Material	Weight												
			MPa	psig	°C	°F	L	H1	H2	W	H1	H2	W		kg	lb											
G3N - 10R	Flanged JIS, ASME, DIN	1½" - 3"	1,0	145	235	455	Table 1 (*1)	140	95	198	5.5	3.7	7.8	Ductile Cast Iron FCD 450	28 - 31 (*2)	62 - 68 (*2)											
		G3N - 16R	1" - 3"	1,6													230										
G5 - 10R		2" - 4"	1,0	145																							
		G5 - 16R	2" - 4"	1,6													230										
GH3N - 10R		1½" - 3"	1,0	145													400	752	139	106	212	5.5	4.2	8.3	Cast Steel SCPH2	38 - 50 (*2)	84 - 110 (*2)
		GH3N - 16R	1" - 3"	1,6																							
		GH3N - 21R	1" - 3"	2,1	305																						
GH5 - 10R		2" - 4"	1,0	145																							
		GH5 - 16R	2" - 4"	1,6	230																						
GH5 - 21R			2" - 4"	2,1	305																						

(*1) Please look at our technical drawings for JIS dimensions.

(*2) Depending on size and flange standard the weight of the traps differs. Please, look at our technical drawings.

Stainless Steel as body material for GH3N and GH5 is available as special design. For more details, please contact MIYAWAKI Inc. or an authorized representative.

GC1

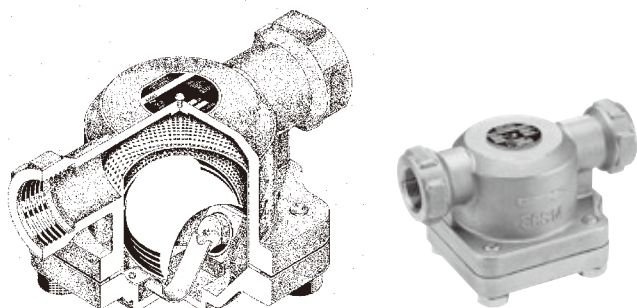

Horizontal installation

GC1V

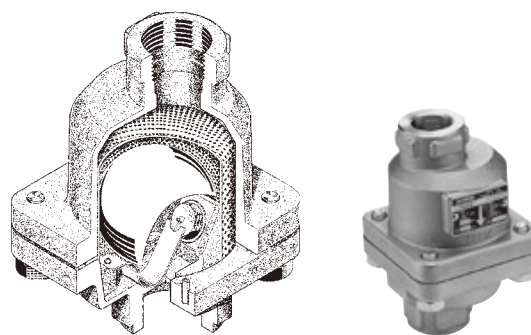

Vertical installation

Dimensions

Screwed, Socket Weld

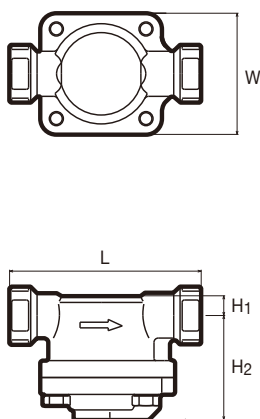

GC1

Flanged

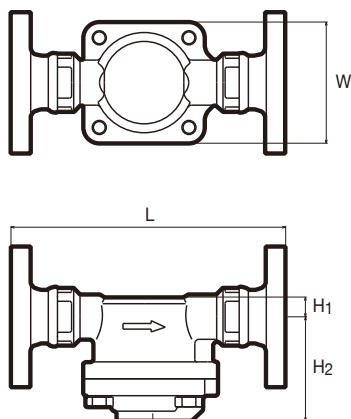

GC1V

Screwed, Socket Weld

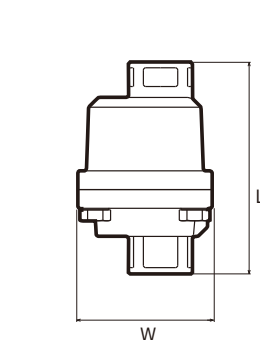

Flanged

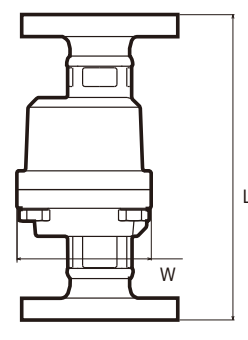

Capacity Chart GC1 / GC1V

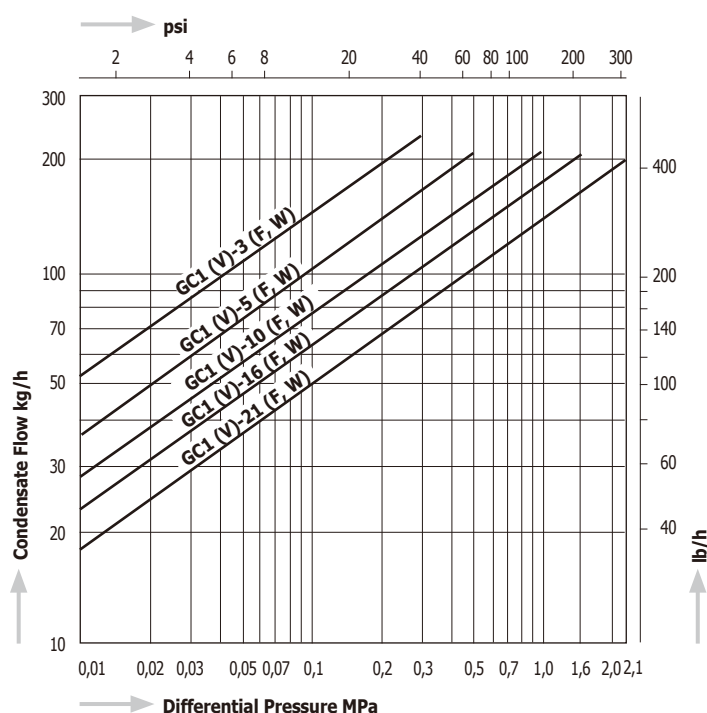

Available pressure ranges GC1/GC1V

Model	Max. Operating Pressure	
	MPa	psig
GC1 / GC1V - 21	2,1	305
GC1 / GC1V - 16	1,6	230
GC1 / GC1V - 10	1,0	145
GC1 / GC1V - 5	0,5	72.5
GC1 / GC1V - 3	0,3	43.5

Model	Connections	Size	Max. Operating Pressure		Max. Operating Temperature		Dimensions (mm)				Dimensions (in)				Body Material	Weight	
			MPa	psig	°C	°F	L	H1	H2	W	L	H1	H2	W		kg	lb
GC1 (GC1V)	Screwed Rc, NPT	1/2"	2,1	305	350	662	127	15	75	86	5.0	0.6	3.0	3.4	Stainless Steel SCS13A	1,8	4.0
		3/4"					136				5.4					1,9	4.2
		1"					140				5.5					2,0	4.4
GC1-W (GC1V-W)	Socket Weld JIS, ASME, DIN	1/2"	2,1	305	350	662	127	15	75	86	5.0	0.6	3.0	3.4	Stainless Steel SCS13A	1,8	4.0
		3/4"					136				5.4					1,9	4.2
		1"					140				5.5					2,0	4.4
GC1-F (GC1V-F)	Flanged JIS, ASME, DIN	1/2"	2,1	305	350	662	175	15	75	86	6.9	0.6	3.0	3.4	Stainless Steel SCS13A	3,3	7.3
		3/4"					195				7.7					4,5	9.9
		1"					215				8.5					5,3	11.7

GH40

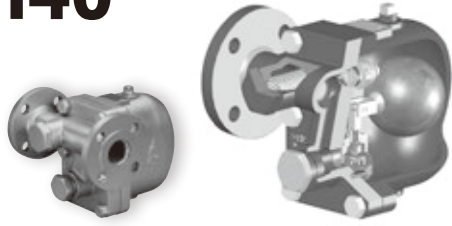

GH50

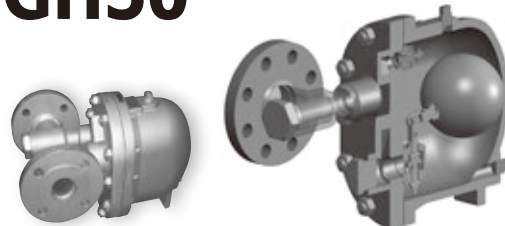

Capacity Chart GH40

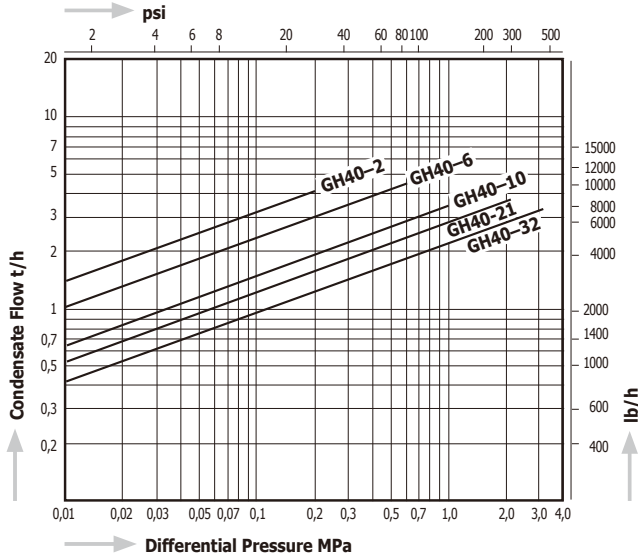

Capacity Chart GH50

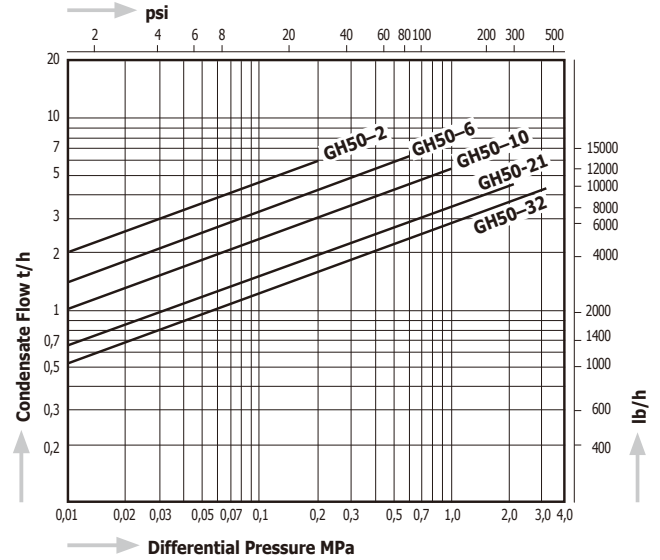

Dimensions

GH40-F

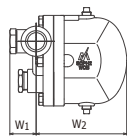
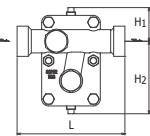

GH40-W

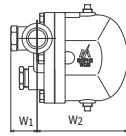
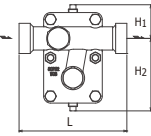

GH50-F

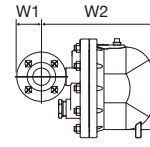
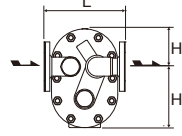

GH50-W

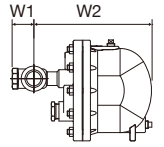
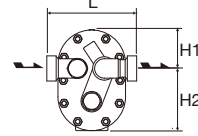

Table 1: Dimensions L and Weight

Model	Size	JIS 10K, 16K, 20K				JIS 30K				JIS 40K				ASME 150lb, 300lb				ASME 600lb				DIN PN40			
		mm	in	kg	lb	mm	in	kg	lb	mm	in	kg	lb	mm	in	kg	lb	mm	in	kg	lb	mm	in	kg	lb
GH40 - F	1½"	230	9.1	24	53	230	9.1	27	60	240	9.5	27	60	230	9.1	24	53	240	9.5	27	60	230	9.1	24	53
	2"									240	9.5							270	10.6						
GH50 - F	1½"	230	9.1	37	82	250	9.8	40	88.2	260	10.2	40	88.2	230	9.1	37	82	270	10.6	40	88.2	230	9.1	37	82
	2"									260	10.2							290	11.4						

Model	Connections	Size	Max. Operating Pressure, PMO		Max. Operating Temperature, TMO		Dimensions (mm)					Dimensions (in)					Body Material	Weight	
			MPa	psig	°C	°F	L	H1	H2	W1	W2	L	H1	H2	W1	W2		kg	lb
GH40 - F	Flanged JIS, ASME, DIN	1½", 2"	3,2	464	400	752	Table 1	80	170	60	210	Table 1	3.2	6.7	2.4	8.3	Cast Steel SCPH2	Table 1	Table 1
GH40 - W	Socket Weld JIS, ASME, DIN	1½"					250	80	170	60	210	9.8	3.2	6.7	2.4	8.3		19	41.9
		2"					260	10.2	10.2	10.2	10.2	10.2	10.2	10.2	10.2	10.2		10.2	10.2
GH50 - F	Flanged JIS, ASME, DIN	1½", 2"					Table 1	107	173	60	330	Table 1	4.2	6.8	2.4	13.0		Table 1	Table 1
GH50 - W	Socket Weld JIS, ASME, DIN	1½"	250	107	173	60	330	9.8	4.2	6.8	2.4	13.0	32	70.6					
		2"	260	10.2	10.2	10.2	10.2	10.2	10.2	10.2	10.2	10.2	10.2	10.2					

Available pressure ranges	Max. Operating Pressure (PMO)											
	MPa		psig		MPa		psig		MPa		psig	
	0,2	29	0,6	87	1,0	145	2,1	305	3,2	464		
Models	GH40-2F, GH40-2W GH50-2F, GH50-2W		GH40-6F, GH40-6W GH50-6F, GH50-6W		GH40-10F, GH40-10W GH50-10F, GH50-10W		GH40-21F, GH40-21W GH50-21F, GH50-21W		GH40-32F, GH40-32W GH50-32F, GH50-32W			

Depending on the flange standard the dimensions and the weight may differ.

Stainless Steel as body material is available as special design. For more details, please contact MIYAWAKI Inc. or an authorized representative.

GH60



GH70

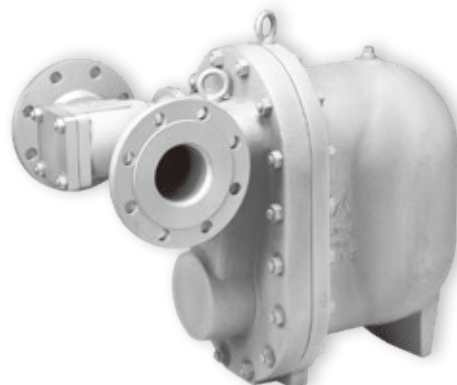

Capacity Chart GH60

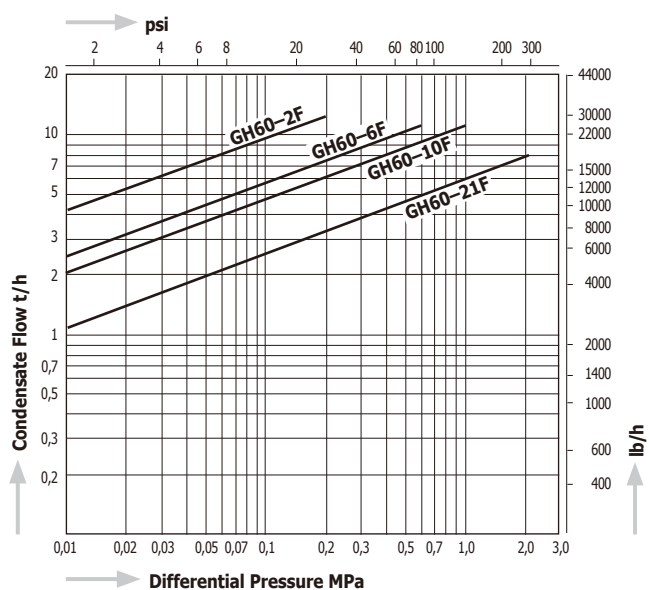

Capacity Chart GH70

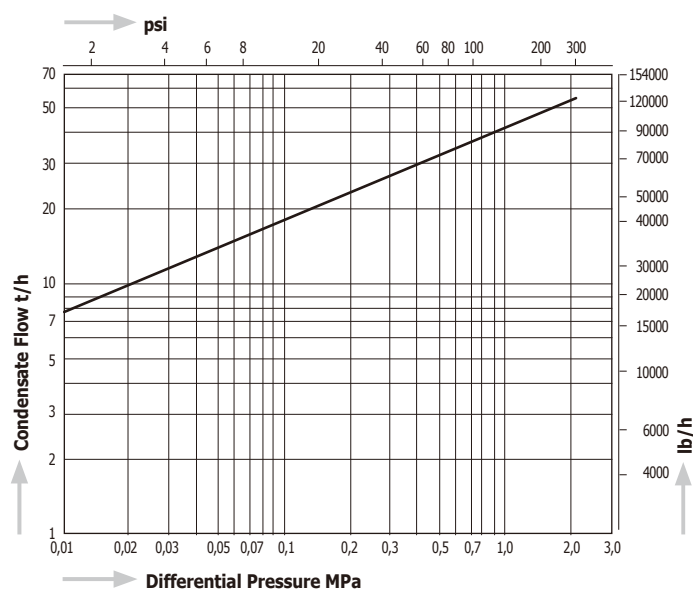

Dimensions GH60

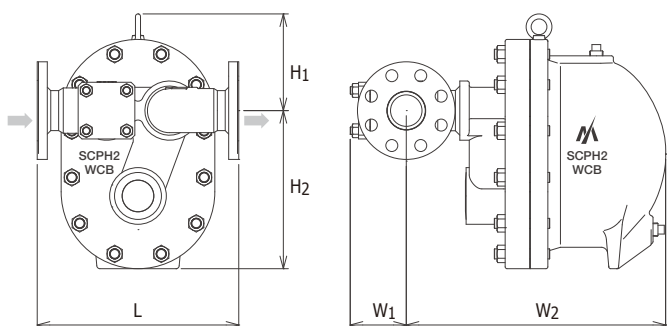

Dimensions GH70

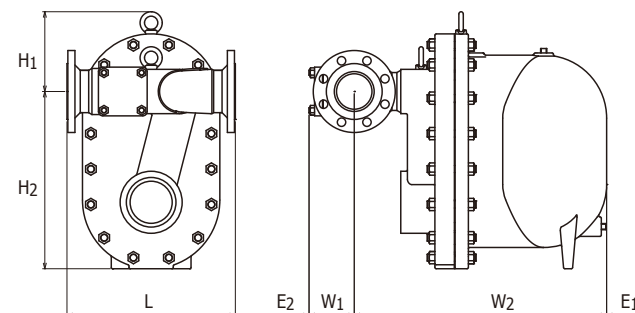

Model	Connect.	Size	Max. Operating Pressure		Max. Differential Pressure, PMX		Max. Operating Temperature, TMO		Dimensions (mm)								Dimensions (in)						Body Material	Weight	
			MPa	psig	MPa	psig	°C	°F	L	H1	H2	W1	W2	E1	E2	L	H1	H2	W1	W2	E1	E2		kg	lb
GH60 -2F	Flanged JIS, ASME, DIN	2" - 2½"	0,2	29	0,2	29	400	752	320	155	250	90	410	-	-	12.6	6.1	9.8	3.5	16.1	-	-	Cast Steel SCPH2	75	165.4
GH60 -6F			0,6	87	0,6	87																			
GH60 -10F			1,0	145	1,0	145																			
GH60 -21F			2,1	305	2,1	305																			
GH70 -21F	Flanged JIS, ASME, DIN	3"	2,1	305	2,1	305	400	752	380	180	400	105	570	330	120	15.0	7.1	15.8	4.1	22.4	13.0	4.7	Cast Steel SCPH2	172	379.3
		4"																							

Stainless Steel as body material is available as special design. For more details, please contact MIYAWAKI Inc. or an authorized representative.

GTH12

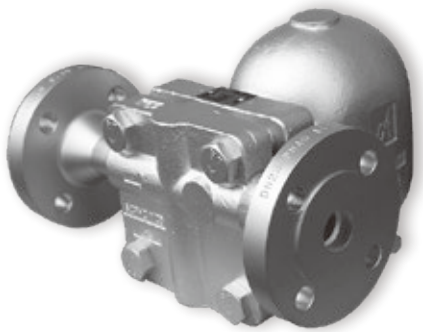

Capacity Chart GTH12

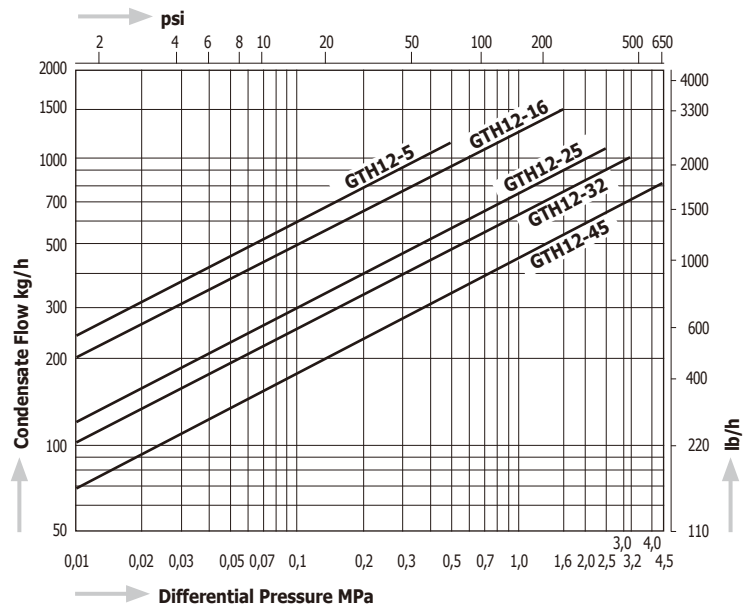

Dimensions

GTH12-F Flanged

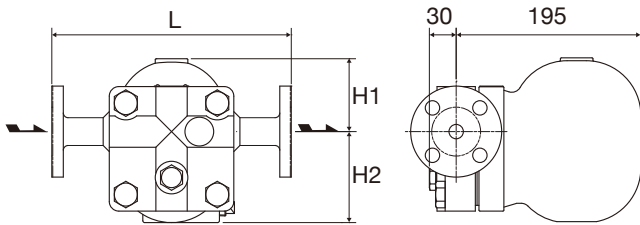

GTH12 Screwed
GTH12-W Socket Weld

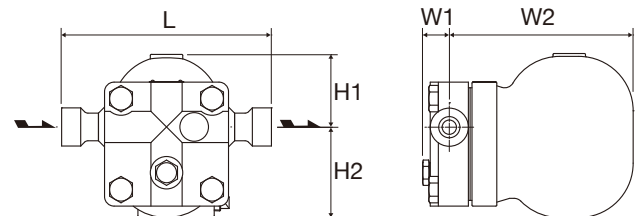

Model	Connections	Size	Max. Operating Pressure		Max. Differential Pressure, PMX		Max. Operating Temperature, TMO		Dimensions (mm)			Dimensions (in)			Body Material	Weight	
			MPa	psig	MPa	psig	°C	°F	L	H1	H2	L	H1	H2		kg	lb
GTH12- 5	Screwed Rc, NPT	½" – 1"	3,2 *	464 *	0,5	73	400 *	752 *	220	75	95	8.7	3.0	3.7	Cast Steel SCPH2	~11,7	~25.8
GTH12- 16					1,6	230											
GTH12- 25					2,5	363											
GTH12- 32					3,2	464											
GTH12- 45			5,0	725	4,5	652	425	800									
GTH12- 5F	Flanged JIS, ASME, DIN	½" – 1"	3,2 *	464 *	0,5	73	400 *	752 *	250	75	95	9.8	3.0	3.7		~15,2	~33.5
GTH12- 16F					1,6	230											
GTH12- 25F					2,5	360											
GTH12- 32F					3,2	464											
GTH12- 45F			5,0	725	4,5	652	425	800									
GTH12- 5W	Socket Weld JIS, ASME, DIN	½" – 1"	3,2 *	464 *	0,5	73	400 *	752 *	220	75	95	8.7	3.0	3.7	~11,7	~25.8	
GTH12- 16W					1,6	230											
GTH12- 25W					2,5	360											
GTH12- 32W					3,2	464											
GTH12- 45W			5,0	725	4,5	652	425	800									

*PMO 5,0 MPa and TMO 425 °C is available as special design.

A vertical version and Stainless Steel as body material are available as special design.

For more details, please contact MIYAWAKI Inc. or an authorized representative.

GTH10

Capacity Chart GTH10

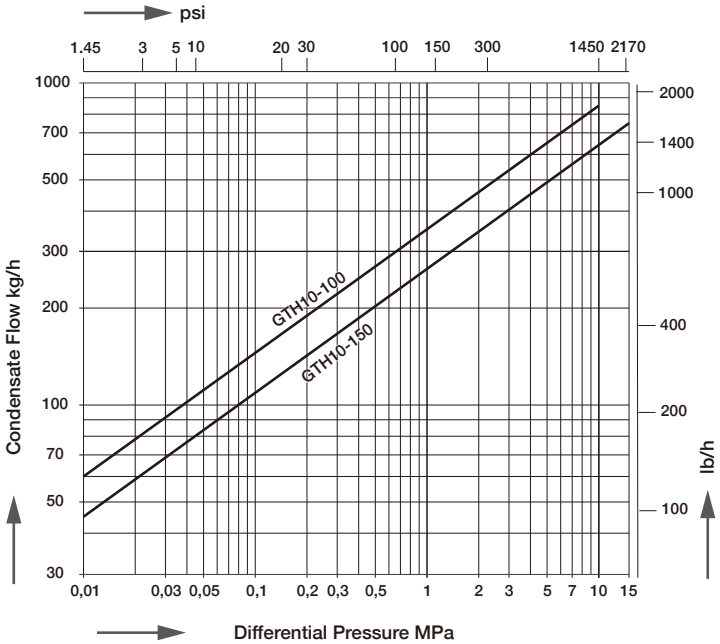

Dimensions

GTH10-W Socket Weld

GTH10-BW Butt Weld

GTH10-F Flanged

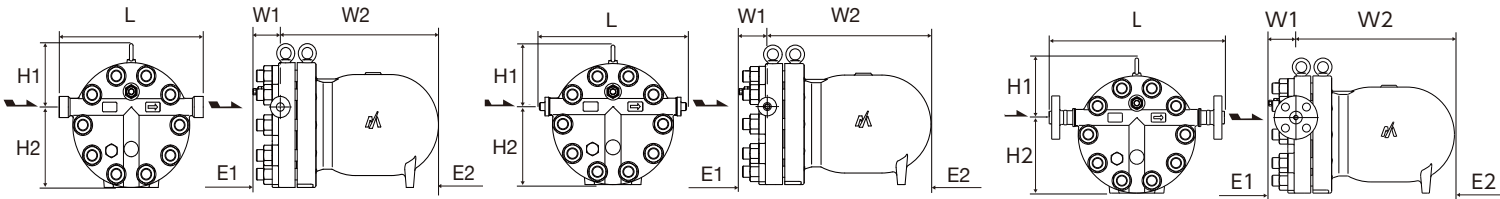

Model	Connections	Size	Max. Operating Pressure		Max. Differential Pressure, PMX		Max. Operating Temperature, TMO		Dimensions (mm)					Dimensions (in)					Body Material	Weight																																														
			MPa	psig	MPa	psig	°C	°F	L	H1	H2	W1	W2	L	H1	H2	W1	W2		kg	lb																																													
GTH10- 100W	Socket Weld JIS, ASME, DIN	1/2" - 1"	10,0 at 500 °C	1450 at 932 °F	10,0	1450	550 at 5,18 MPa	1022 at 751 psi	400	165	210	80	440	6.5	8.3	3.1	17.3	A217 WC9	111	244																																														
GTH10- 150W			15,0 at 379 °C	2175 at 714 °F	15,0	2175															15.7																																													
GTH10- 100BW	Butt Weld JIS, ASME	1/2" - 1"	10,0 at 500 °C	1450 at 932 °F	10,0	1450			550 at 5,18 MPa												1022 at 751 psi	395	165	210	80	440	6.5	8.3	3.1	17.3	A217 WC9	111	244																																	
GTH10- 150BW			15,0 at 379 °C	2175 at 714 °F	15,0	2175																												15.5																																
GTH10- 100F	Flanged ASME/JPI	1/2"	10,0 at 500 °C	1450 at 932 °F	10,0	1450																550 at 5,18 MPa												1022 at 751 psi	485	165	210	80	440	6.5	8.3	3.1	17.3	A217 WC9	115	254																				
		3/4"																																													495	19.5																		
		1"																																													505	19.8																		
GTH10- 150F		Flanged ASME/JPI																																	1/2"												15,0 at 379 °C	2175 at 714 °F	15,0	2175	550 at 5,18 MPa	1022 at 751 psi	485	165	210	80	440	6.5	8.3	3.1	17.3	A217 WC9	115	254		
																																			3/4"																														495	19.5
																																			1"																														505	19.8
GTH10- 100F	Flanged PN160		DN15	10,0 at 500 °C	1450 at 932 °F	10,0	1450	550 at 5,18 MPa		1022 at 751 psi	475	165	210	80	440	6.5	8.3	3.1	17.3	A217 WC9															113																		249													
			DN25																																																														495	19.5
GTH10- 150F			Flanged PN160						DN15		15,0 at 379 °C										2175 at 714 °F		15,0	2175	550 at 5,18 MPa	1022 at 751 psi	475	165	210	80	440	6.5	8.3																																3.1	17.3
		DN25							495																																						19.5																			

G11N/G12N

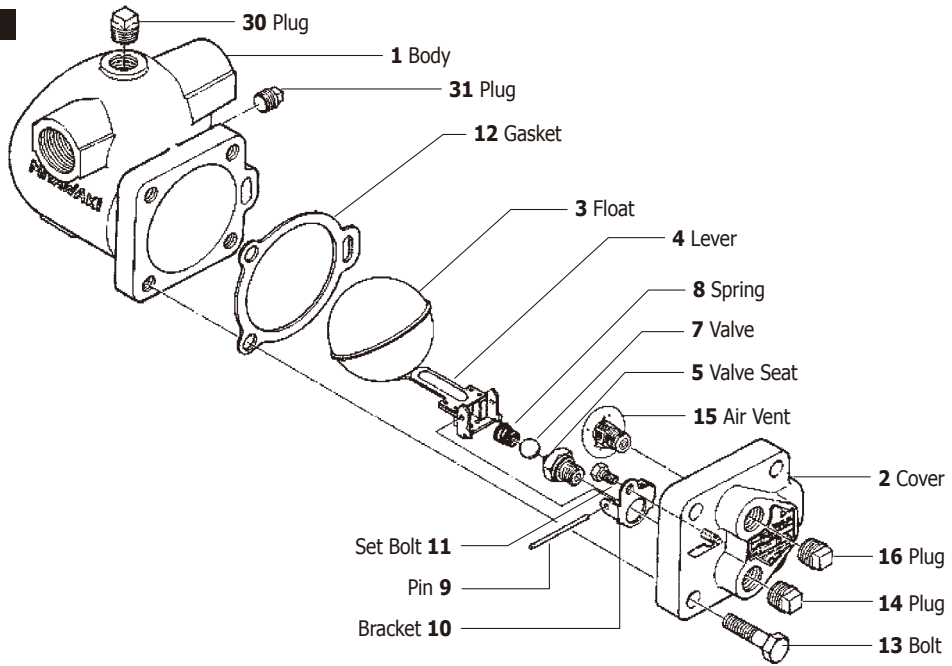

G15N

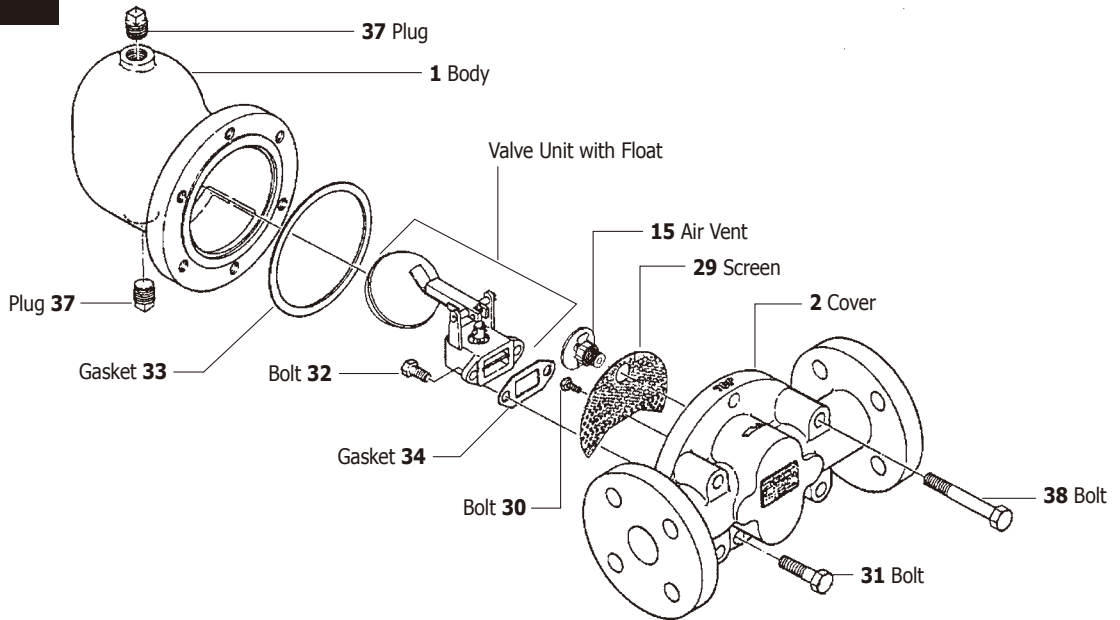

G3N, GH3N, G5, GH5

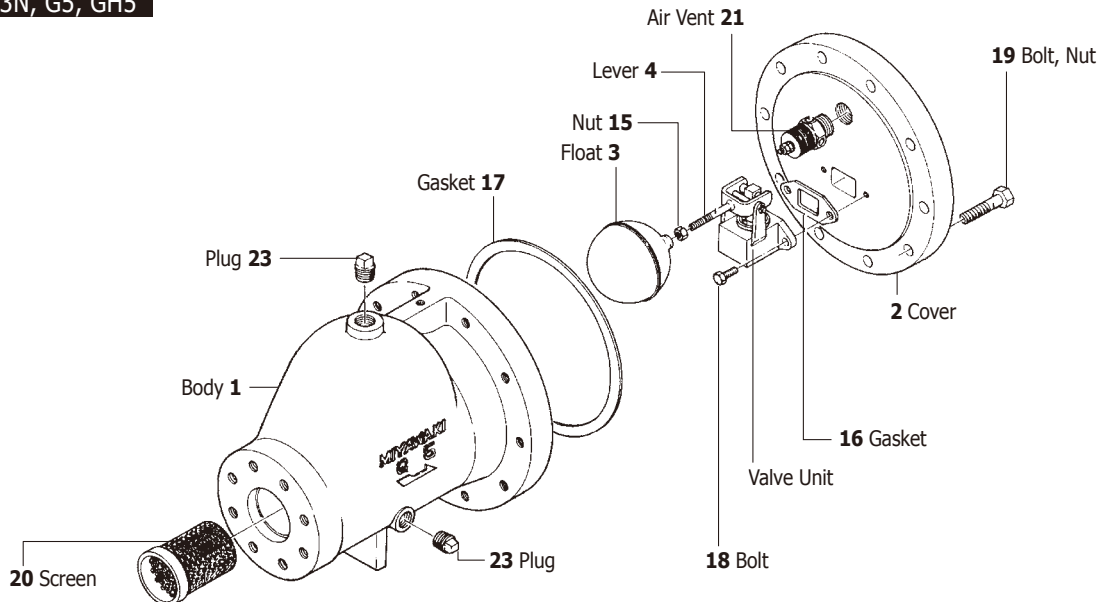

GC1

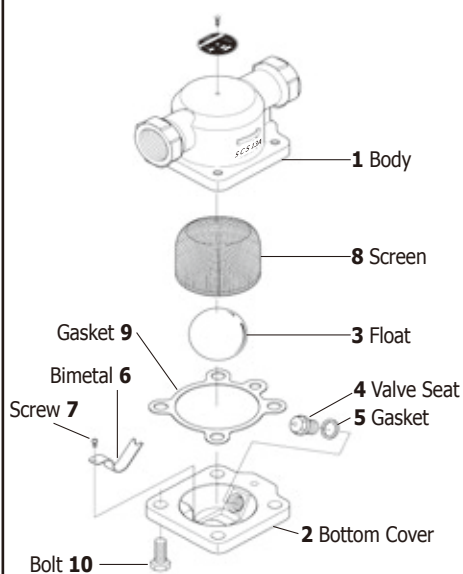

GC1V

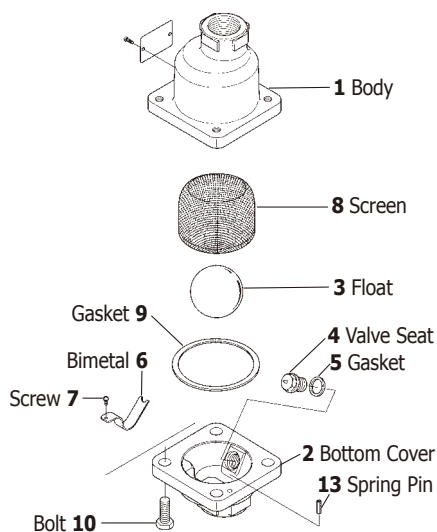

G20N

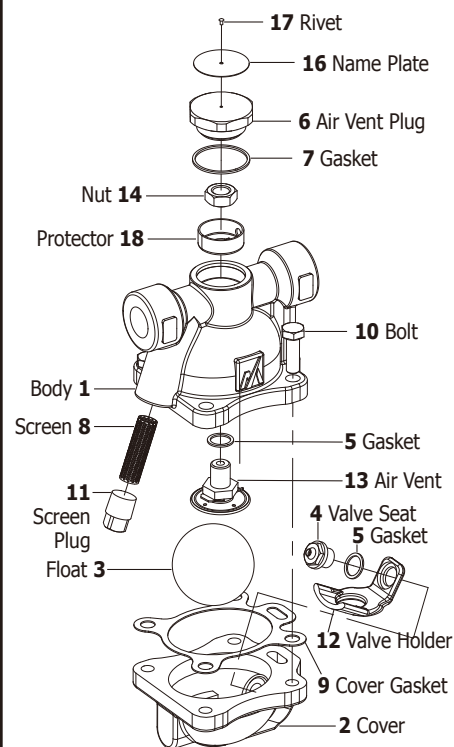

GC20

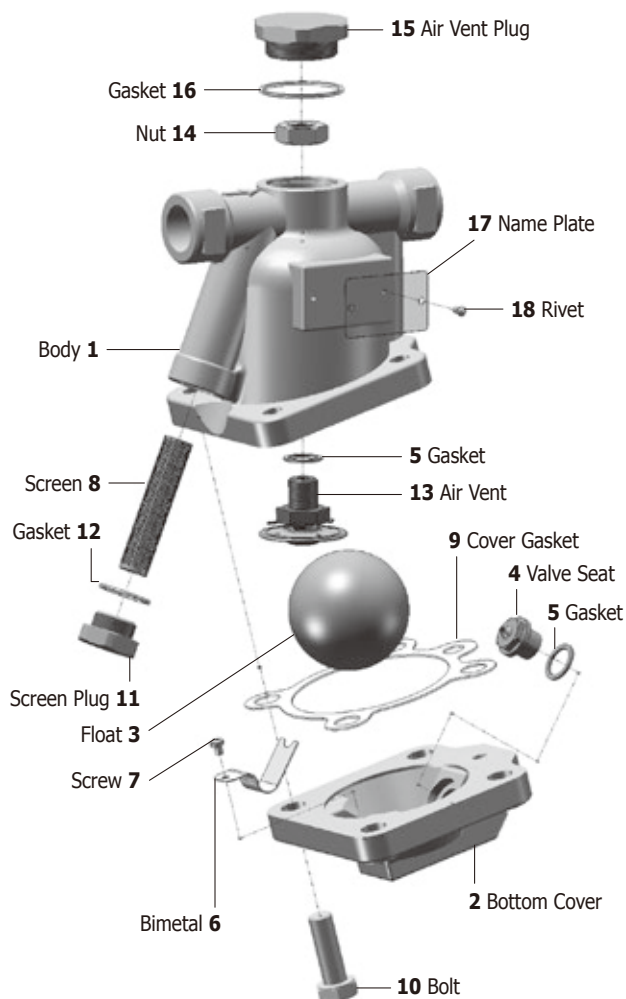

G30

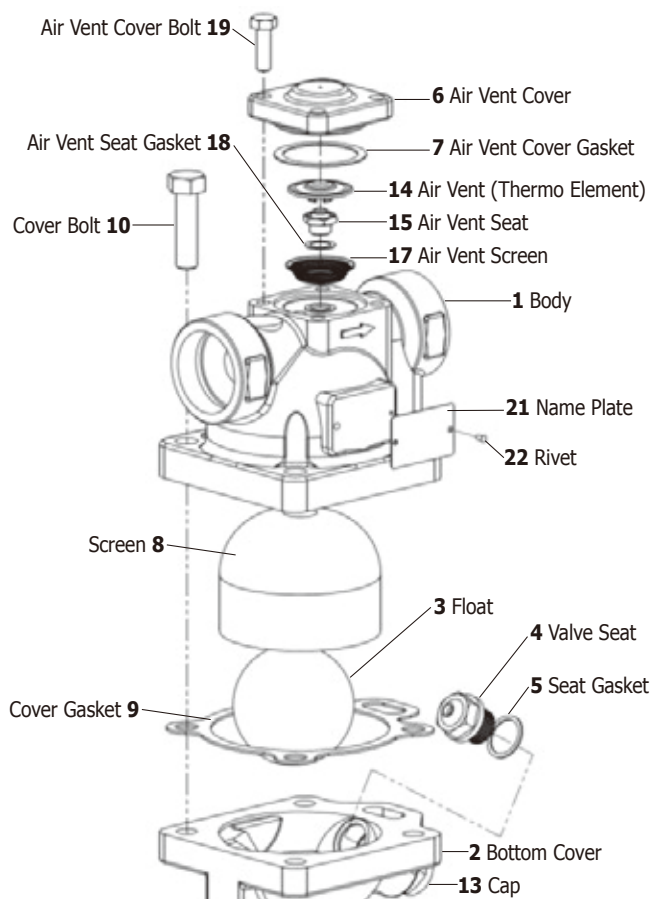

GH2

Valve Unit

- 5 Valve Seat
- 6 Valve
- 7 Holder
- 8 Lever Nut
- 9 Nut
- 10 Connector
- 11 Nut
- 12 Guide Wing
- 13 Pin
- 32 Baffle Plate
- 39 Pin
- 43 Shaft
- 44 Collar
- 45 Split Pin
- 47 Spring Pin

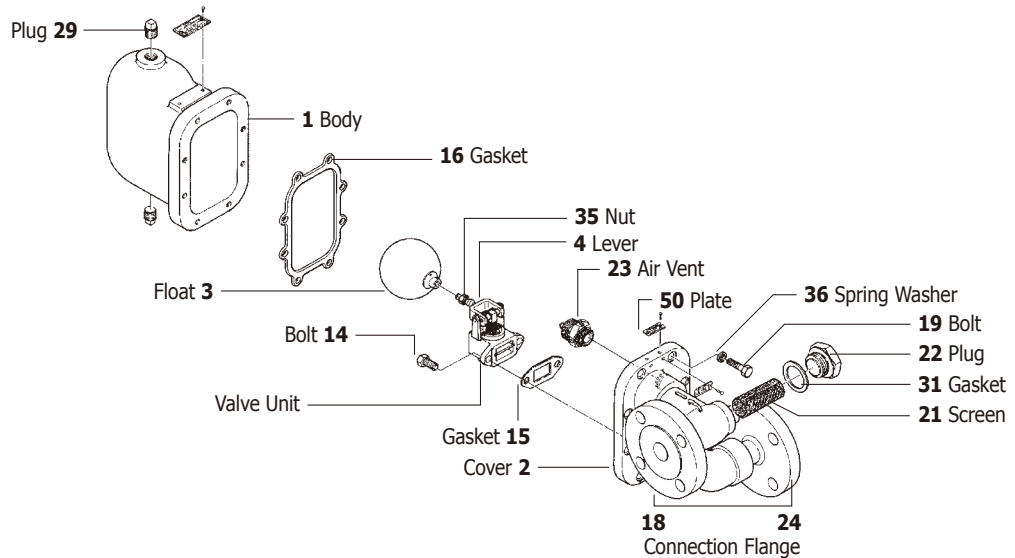

GH4, GH6, GH8

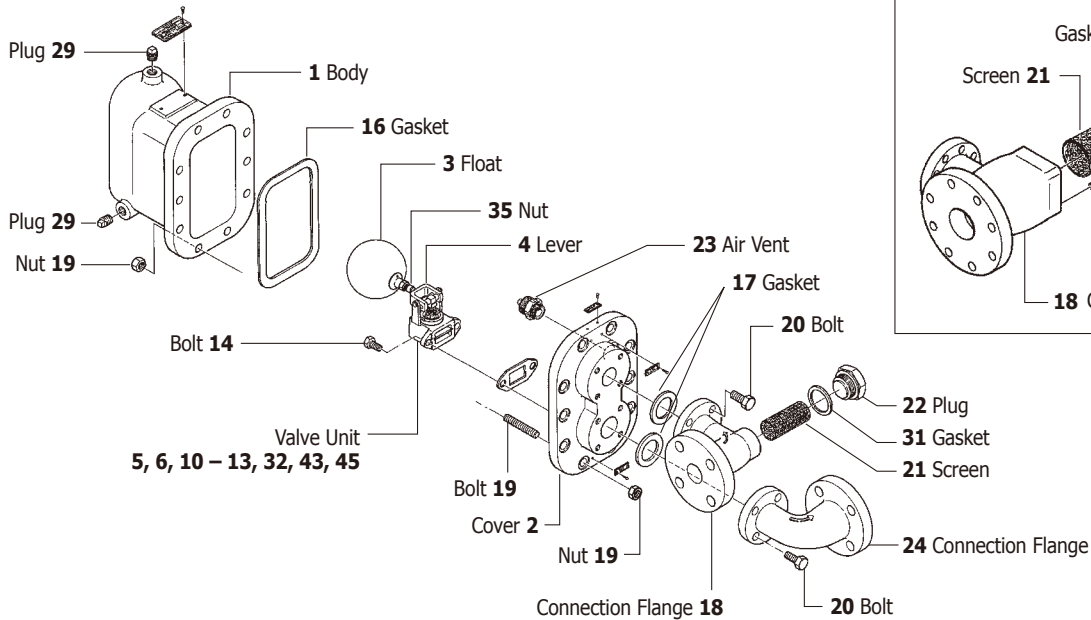

GH8 only

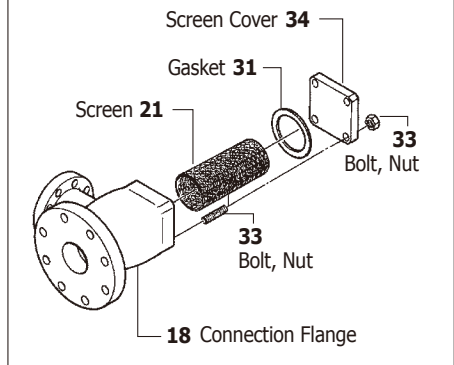

GH40

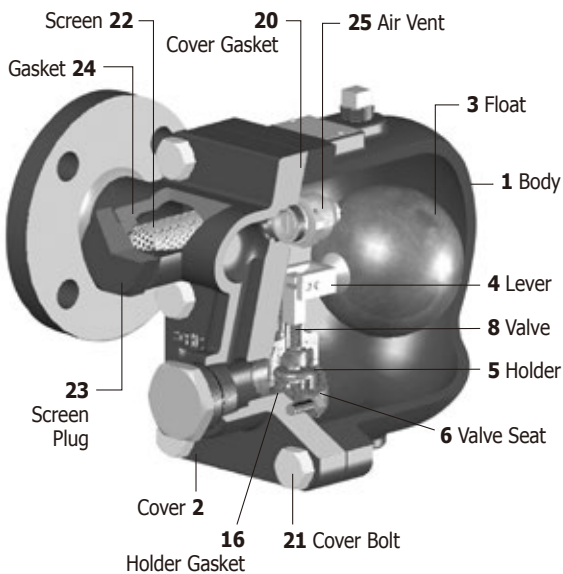

GTH12

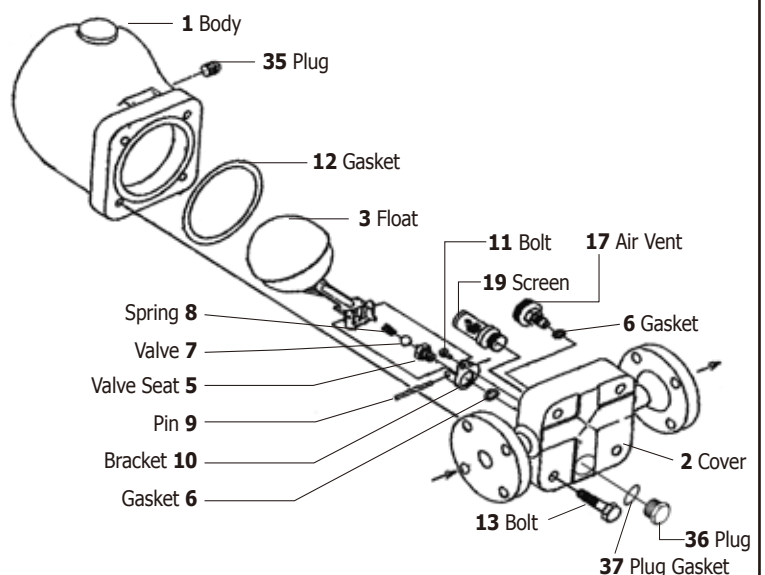

GH50

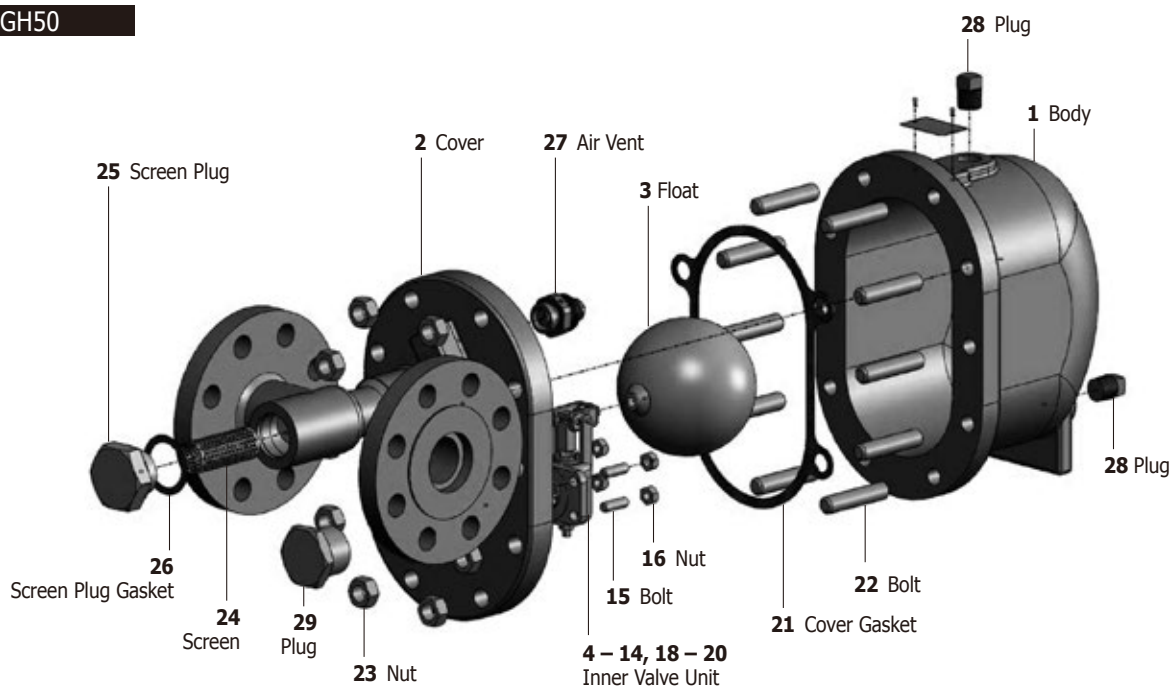

GH60

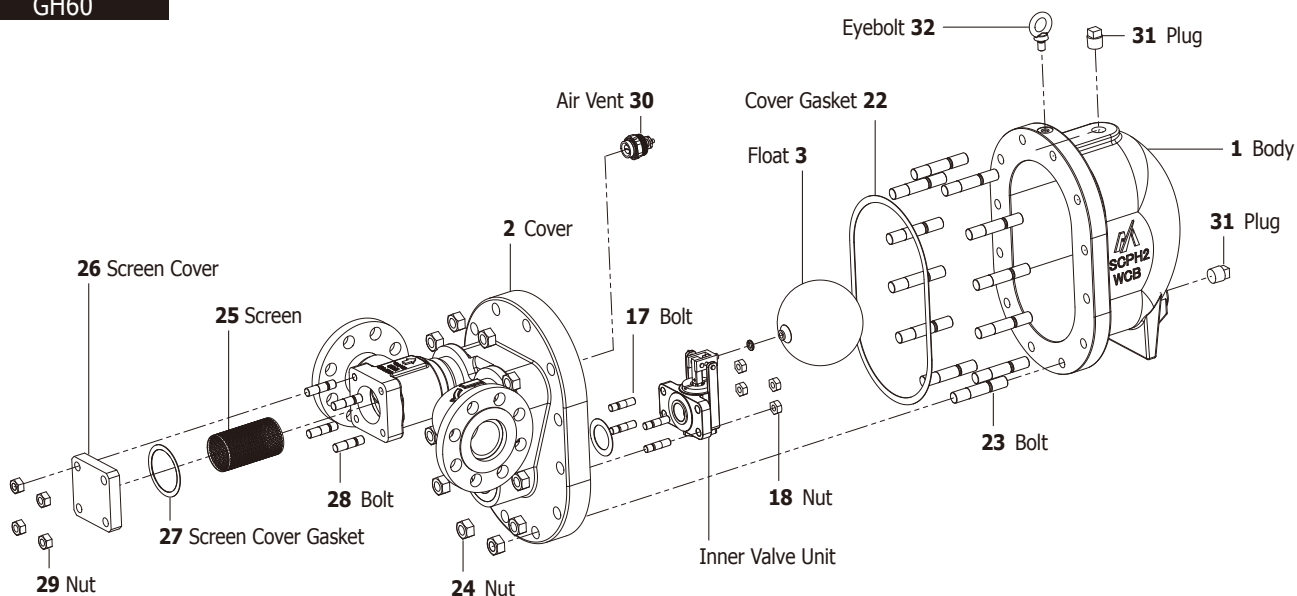

GH70

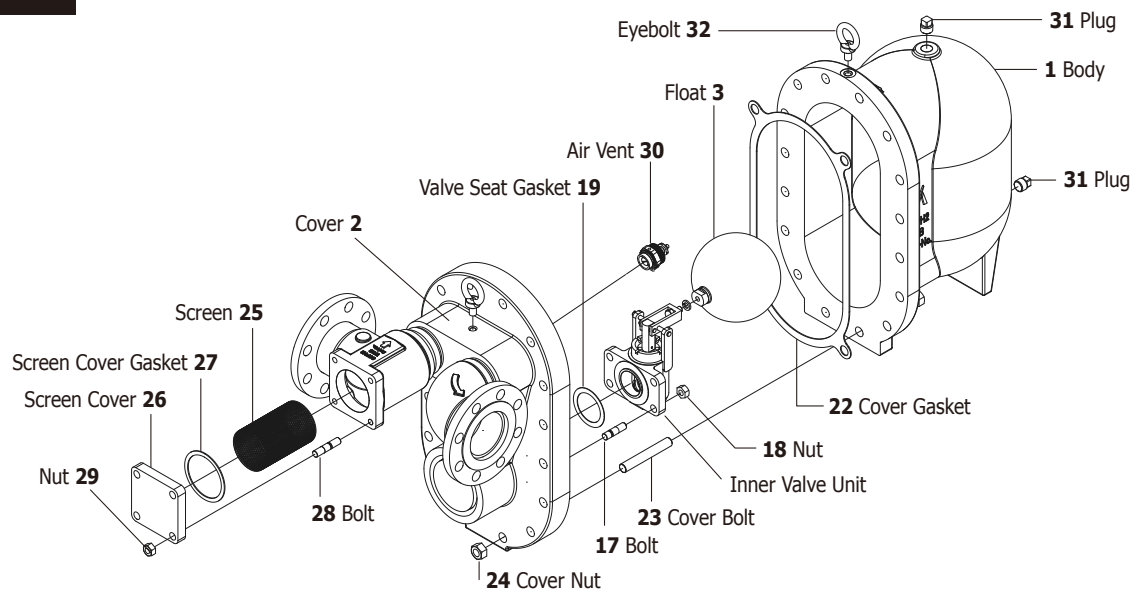

GTH10

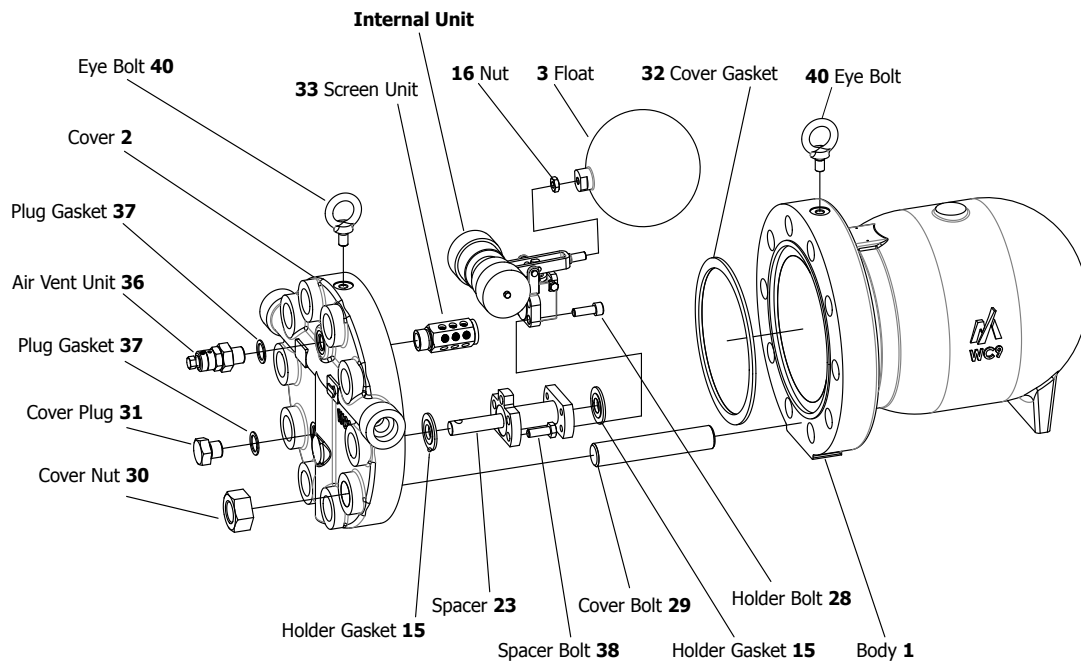

Steam Traps with Two-bolt Connection

SERIES UNC, DC1, SU2

Steam Traps with Two-bolt Connection are intended to make steam trap replacement as easy and quick as possible. It should be mostly unnecessary to remove the body from the pipeline. Steam trap maintenance and replacement are executed by unscrewing the two bolts and removing the steam trap part from the body.

Models

Body

UNC

Connector Body for steam traps with Two-bolt Connection, with an internal strainer (Y-type)

Steam Traps

DC1-21U

Balanced Pressure Thermostatic Steam Trap

SU2-32U

Thermodynamic Steam Trap

Features

- Made from stainless steel
- At time of non-operation self-draining
- Can be installed both horizontally and vertically
- Easy in-line inspection and maintenance
- Lightweight, compact design

Suitable for

light to medium condensate loads: steam tracing, steam main drips, small heat exchangers, unit heaters, steam heating coils, sterilizers and many other applications in the petrochemical, chemical, textile, food, pharmaceutical, and other industries.

Installation Example

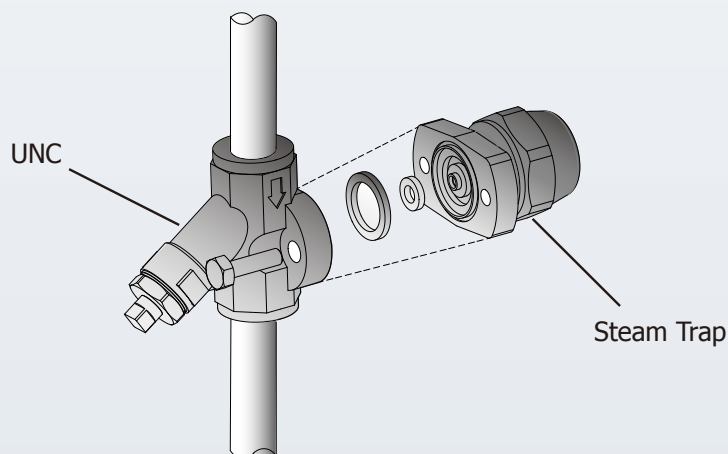

Steam Traps with Two-bolt Connection

DC1-21U

Balanced Pressure
Thermostatic Type



SU2-32U

Thermodynamic Type



All models:

With stainless steel body and stainless steel internals. For horizontal and vertical installation. Two-bolt connection for simplified replacement of the steam trap.

Capacity Chart DC1-21U

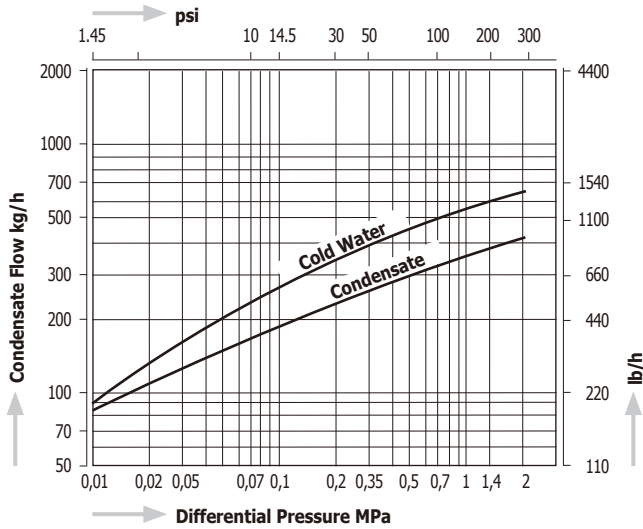

Capacity Chart SU2-32U

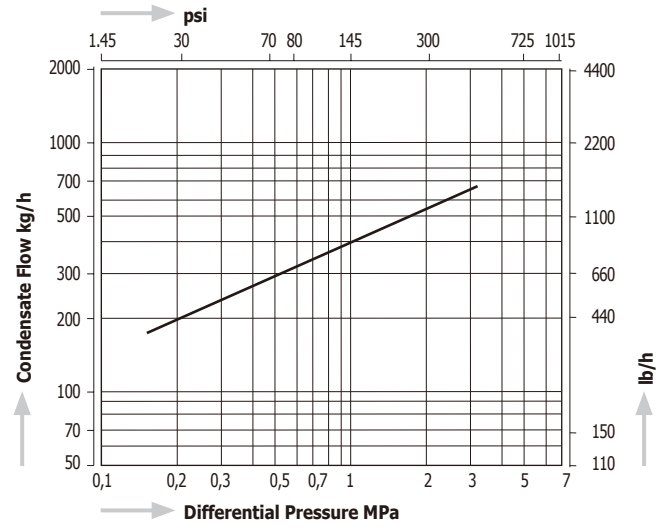

Dimensions

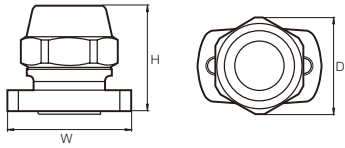

Dimensions

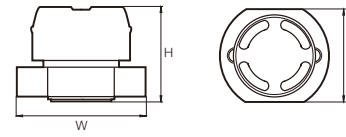

Model	Connection	Max. Operating Pressure		Max. Operating Temperature		Dimensions (mm)			Dimensions (in)			Body Material	Weight	
		MPa	psig	°C	°F	D	H	W	D	H	W		kg	lb
DC1-21U	Universal Two-bolt Connection	2,1	305	235	455	55	62	70	2.2	2.4	2.8	Stainless Steel CF8M	0,8	1.8
SU2-32U		3,2	464	350	662	60	55	70	2.4	2.2	2.8			

UNC

Connector Body for Models:
DC1-21U & SU2-32U

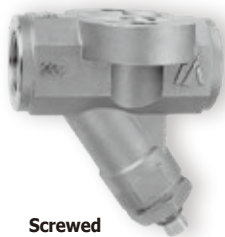

Dimensions

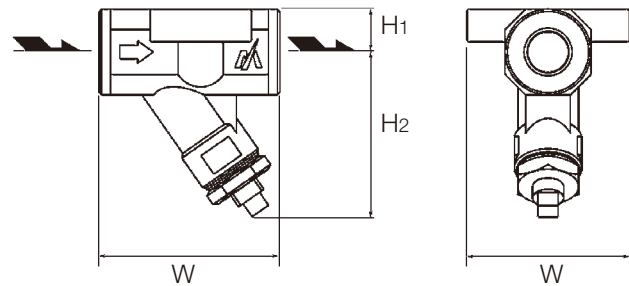

Model	Connection	Size	Max. Operating Pressure		Max. Operating Temperature		Dimensions (mm)				Dimensions (in)				Body Material	Weight	
			MPa	psig	°C	°F	L	H ₁	H ₂	W	L	H ₁	H ₂	W		kg	lb
UNC	Screwed Rc, NPT	1/2" 3/4"	3,2	464	400	752	80	19	73	72	3.2	0.8	2.9	2.8	Stainless Steel A351CF8M	1,0	2.2
UNC-W	Socket Weld																

Pumping Traps

SERIES GL

Pumping Traps transport low pressure condensate into a higher location / pressure line. They are used to drain condensate from process application where the pressure is not sufficient to push the condensate to the condensate return lines or to the condensate vessel. Pumping traps are utilizing steam, air or gases for operation and have no electric components which may fail.

Models	GL11	Small compact Ductile Cast Iron pumping trap for condensate recovery
	GL81	Ductile Cast Iron pumping trap for the recovery of large condensate amounts
	GLP81	Carbon steel pumping trap for the recovery of large condensate amounts

- Features**
- Can be used in hazardous areas as there is no electricity needed.
 - Work with a low filling head
 - Air/N₂ or saturated steam can be used as motive medium
 - The internal parts are manufactured of high-quality stainless steel

Applications

Condensate return from low pressure installations, condensate return to places located higher than the condensate vessel, condensate return from vacuum systems

Operating principle

condensate steam

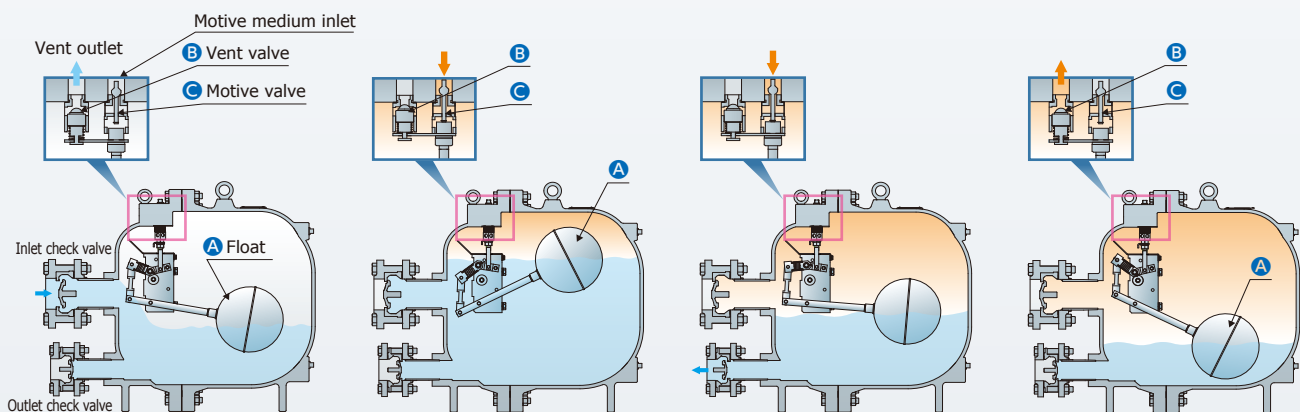

1

On startup, **A** is at the low position, and **B** is opened and **C** is closed.

As condensate flows into the pumping trap through the inlet check valve, **A** rises.

2

When **A** rises to its high position, **B** is closed and **C** is opened.

Then, motive medium flows into the pumping trap and the pressure in the pumping trap rises.

3

When the pressure in the pumping trap becomes higher than the outlet pressure, the outlet check valve opens and the condensate is discharged from the outlet.

4

As the condensate level in the pumping trap falls, **C** is closed and **B** is opened.

The increased pressure in the pumping trap is released through **B**.

When the pressure in the pumping trap falls and is equal to the inlet pressure, condensate flows into the pumping trap again and the operating cycle **1** to **4** is repeated.

GL11

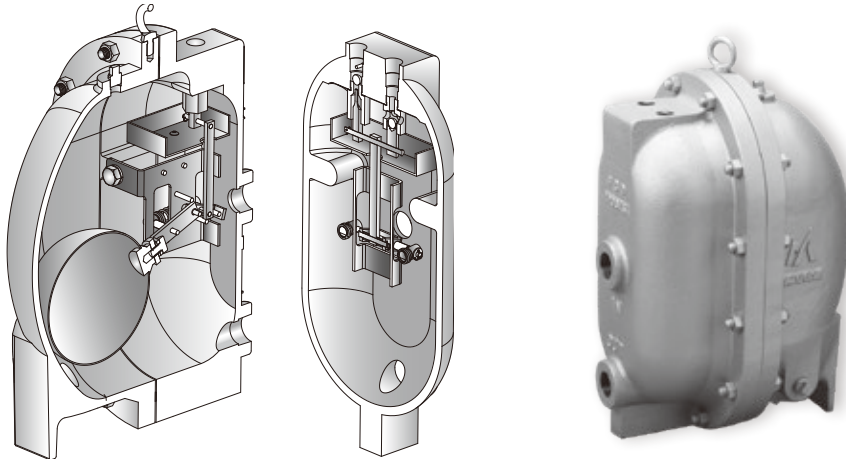

Flow Capacity Charts

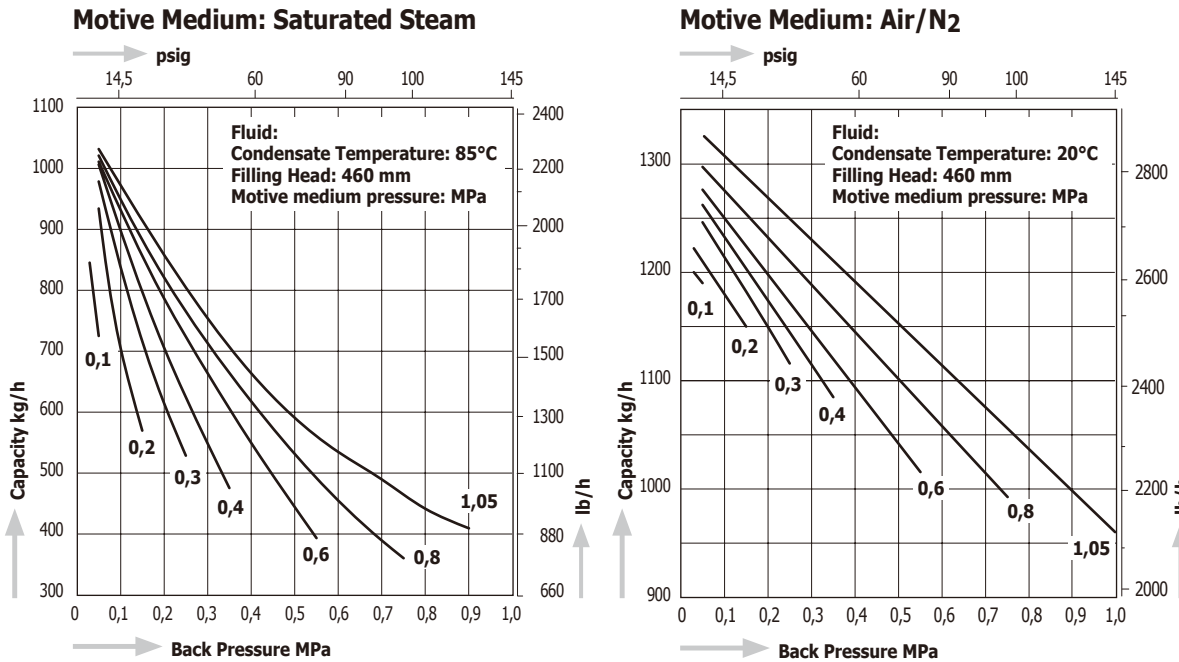

Capacity for other filling heads:

To get the capacity for other filling heads multiply the capacity of this chart by the "FH-factors".

Filling Head		FH-factors
mm	in	
120	4.7	0,79
300	11.8	0,92
460	18.1	1,00
700	27.6	1,06
1000	39.4	1,11
1100	43.3	1,12

Dimensions

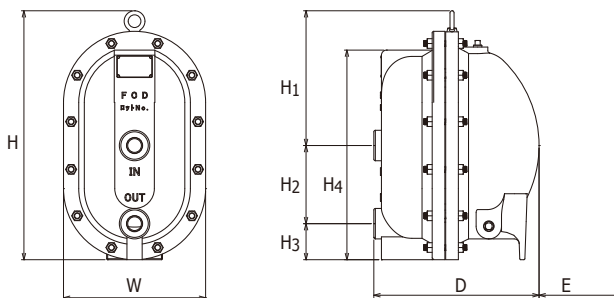

Recommended standard receiver tank dimensions:

Diameter: 8" / DN200
 Length: 580 mm / 22.8 in
 If a receiver tank is not available, a standard pipe (size 3" / DN80) can be used as condensate reservoir.
 Use the following pipe length:

Connection				Max. Allowable Pressure PMA		Max. Allowable Temperature TMA		Max. Operating Pressure PMO		Max. Operating Temperature TMO	
Inlet Condensate	Outlet Condensate	Inlet Motive Medium	Venting Outlet	MPa	psig	°C	°F	MPa	psig	°C	°F
1" Rc	1" Rc	½" Rc	½" Rc	1,6	232	220	428	1,05	152	185	365

Condensate amount	Length			
	kg/h	lb	mm	in
100	220	290	11.4	
200	440	580	22.8	
400	880	1150	45.3	
600	1.320	1730	68.1	
800	1.760	2300	90.6	
1000	2.220	2870	113.0	
1200	2.640	3450	135.8	
1300	2.860	3730	146.9	

Dimensions										Body Material		Weight						
H	H1	H2	H3	H4	D	W	E*											
mm	in	mm	in	mm	in	mm	in	mm	in	mm	in	kg	lb					
495	19.5	270	10.6	154	6.1	70	2.8	413	16.3	325	12.8	280	11.0	>165	>6.5	Ductile Cast Iron FCD450 comparable with EN-GJS-450-10 (EN-JS1040)	50	110

*Maintenance space

GL81

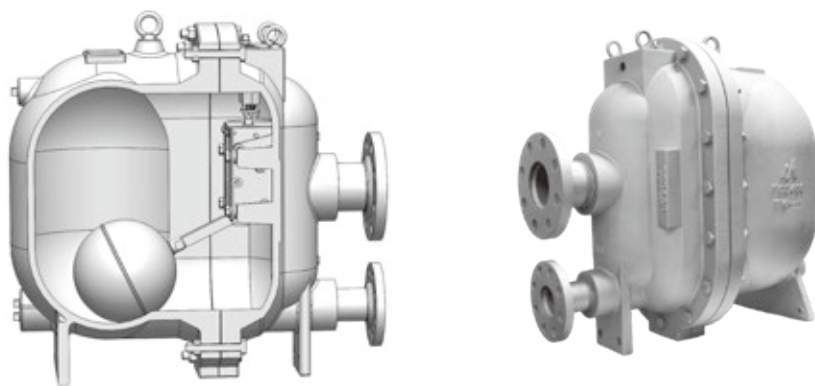

Model: GL81

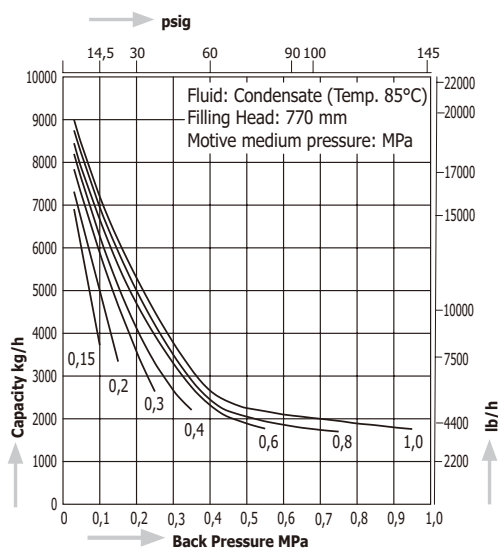

Model: GL81E

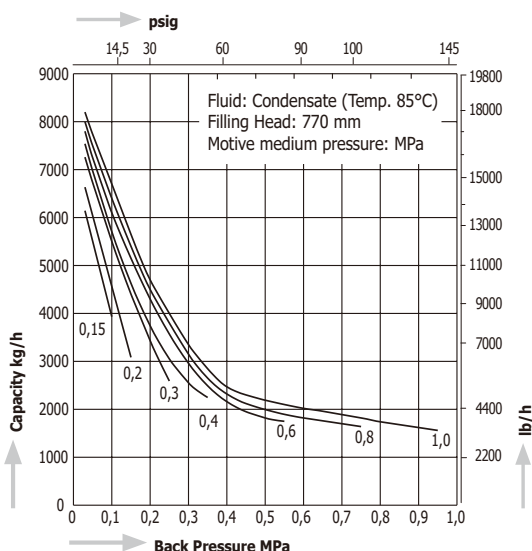

Capacity for other filling heads:

To get the capacity for other filling heads multiply the capacity of this chart by the "FH-factors".

Filling Head		FH-factors
mm	in	
150	5.9	0,66
270	10.6	0,75
370	14.5	0,82
570	22.4	0,92
770	30.3	1,00
970	38.2	1,01
1270	50.0	1,03

Model GL81 and GL81E: To get the capacity for air/N₂ as motive medium, please ask MIYAWAKI Inc. or an authorized representative.

Model	Connection				Max. Allowable Pressure PMA		Max. Allowable Temperature TMA		Max. Operating Pressure PMO		Max. Operating Temperature TMO	
	Inlet Condensate	Outlet Condensate	Inlet Motive Medium	Venting Outlet	MPa	psig	°C	°F	MPa	psig	°C	°F
GL81E	Flanged PN16, ASME 150lb		Screwed Rc		1,6	232	220	428	1,05	152	185	365
	DN80 (3")	DN50 (2")	1/2"	1"								
GL81	Flanged JIS16KFF, ASME 150lb		Screwed Rc		1,6	232	220	428	1,05	152	185	365
	DN80 (3")	DN50 (2")	1/2"	1"								

Model	Dimensions											Body Material		Weight							
	H		H1		H2		H3		D		D1			W		E*		kg	lb		
	mm	in	mm	in	mm	in	mm	in	mm	in	mm	in	mm	in	mm	in					
GL81E	670	26.4	220	8.7	123	4.8	579	22.8	680	26.8	240	9.4	368	14.5	50	2.0	> 380	> 15.0	Ductile Cast Iron FCD450 comparable with EN-GJS-450-10 (EN-JS1040)	160	353
GL81																					

*Maintenance space

Dimensions

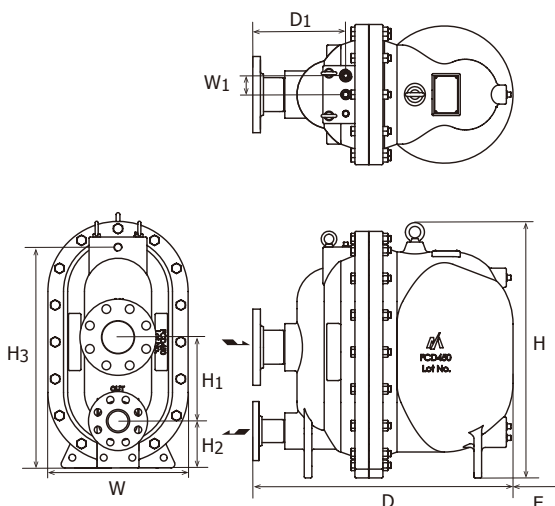

Steam and Air/N₂ consumption chart for GL81 (E)

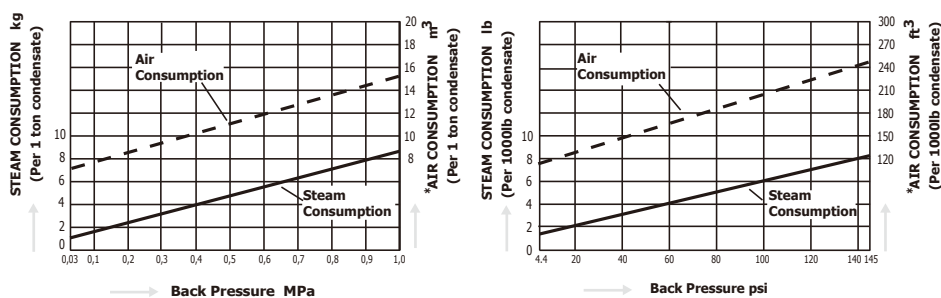

Equivalent consumption of air at 20°C (68°F) under atmospheric pressure.

GLP81

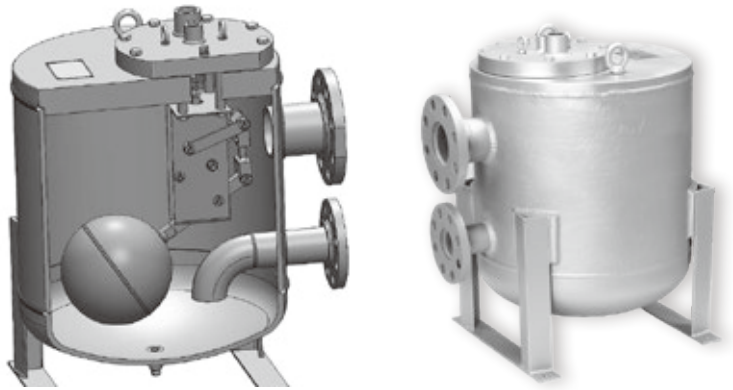

Flow Capacity Charts

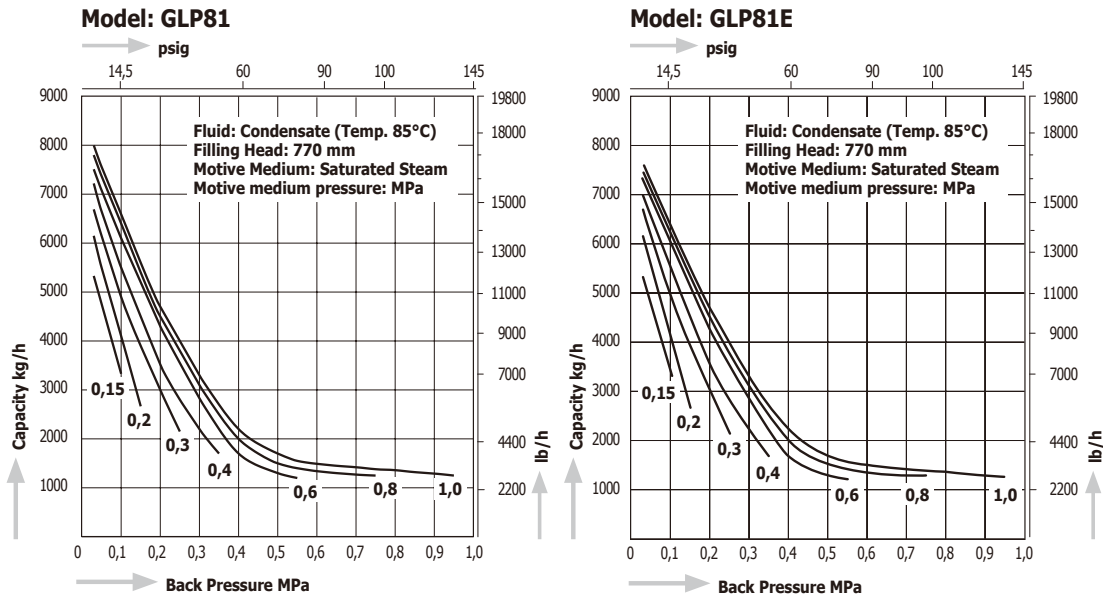

Capacity for other filling heads:

To get the capacity for other filling heads multiply the capacity of this chart by the "FH-factors".

Filling Head		FH-factors
mm	in	
150	5.9	0,66
270	10.6	0,75
370	14.5	0,82
570	22.4	0,92
770	30.3	1,00
970	38.2	1,01
1270	50.0	1,03

Model GLP81 and GPL81E: To get the capacity for air/N₂ as motive medium, please, see our Technical Bulletin No. 017-002.

Model	Connection				Max. Allowable Pressure PMA		Max. Allowable Temperature TMA		Max. Operating Pressure PMO		Max. Operating Temperature TMO	
	Inlet Condensate	Outlet Condensate	Inlet Motive Medium	Venting Outlet	MPa	psig	°C	°F	MPa	psig	°C	°F
GLP81E	Flanged PN16, ASME 150lb	DN50 (2")	Screwed Rc		1,6	232	220	428	1,05	152	185	365
	DN80 (3")		1"									
GLP81	Flanged JIS16KFF, ASME 150lb	DN50 (2")	Screwed Rc		1,6	232	250	482	1,05	152	185	365
	DN80 (3")		1"									

Model	Dimensions														Body Material	Weight			
	H		H1		H2		D		D1		D2		W			E*	kg	lb	
	mm	in	mm	in	mm	in	mm	in	mm	in	mm	in	mm	in					
GLP81E	670	26.4	210	8.3	250	9.8	550	21.7	380	15.0	400	15.7	457	18.0	> 550	> 21.7	Carbon steel (Details see Technical drawing)	112	246
GLP81	660	26.0			230	9.1	550	21.7			380	15.0						150	330

*Maintenance space

Stainless Steel as body material for GLP81 is available as special design. For more details, please contact MIYAWAKI Inc. or an authorized representative.

Dimensions

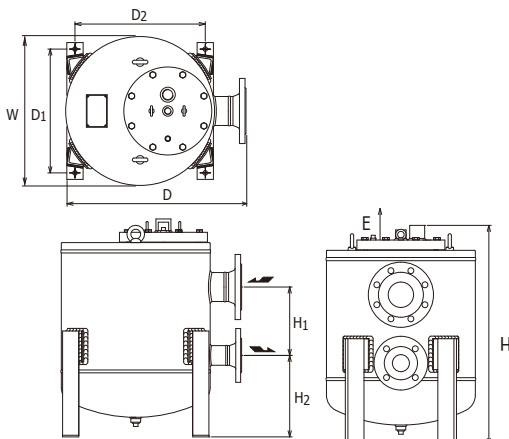

Steam and Air/N₂ consumption chart for GLP81 (E)

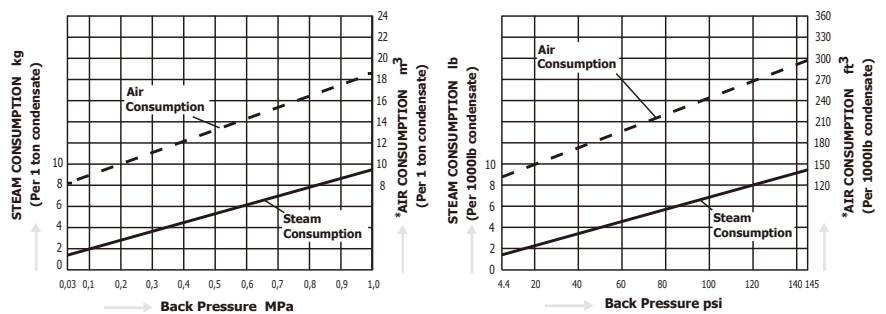

Equivalent consumption of air at 20°C (68°F) under atmospheric pressure

Installation line examples

Open system

● GL81(E)

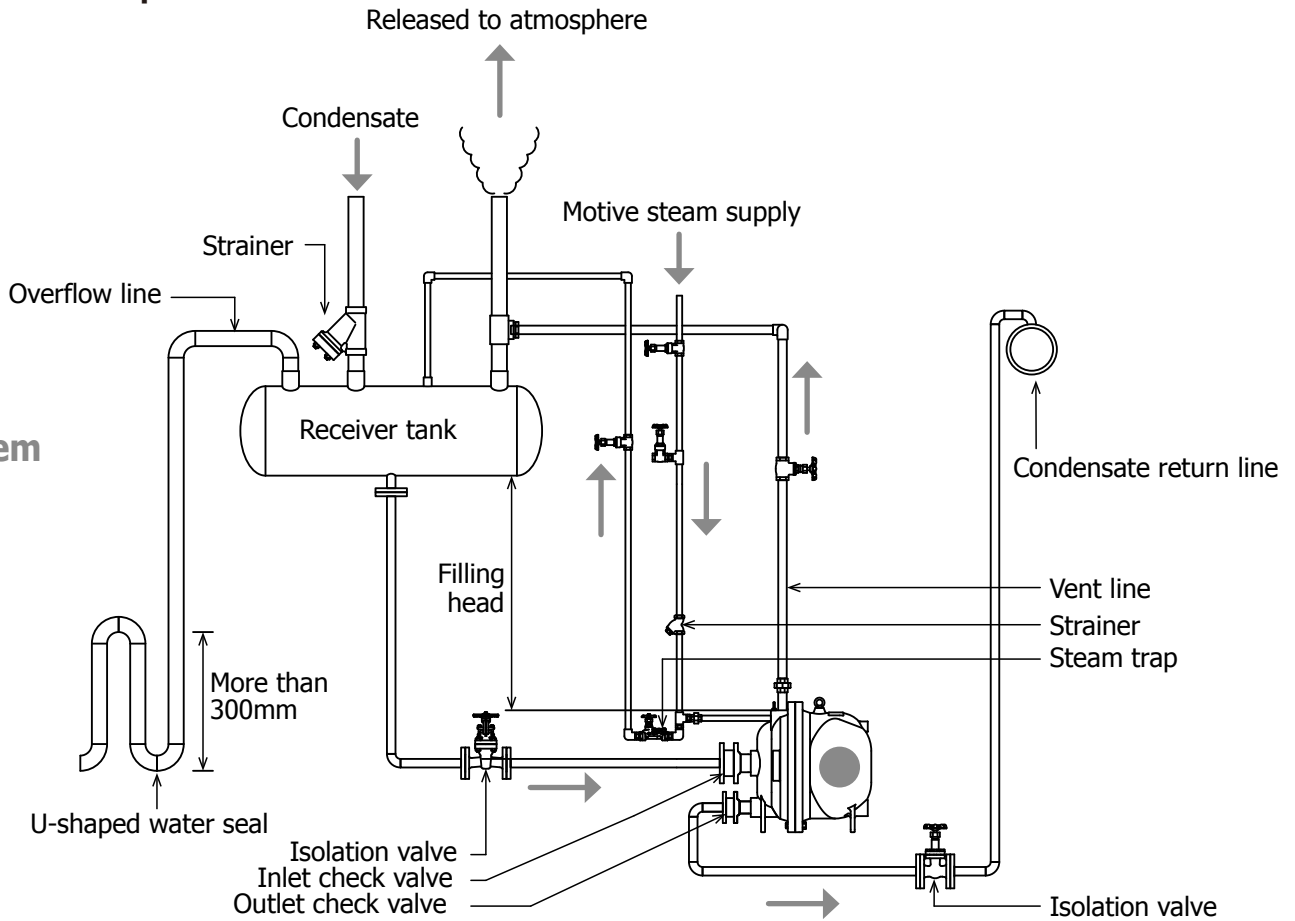

Closed system

● GL81(E)

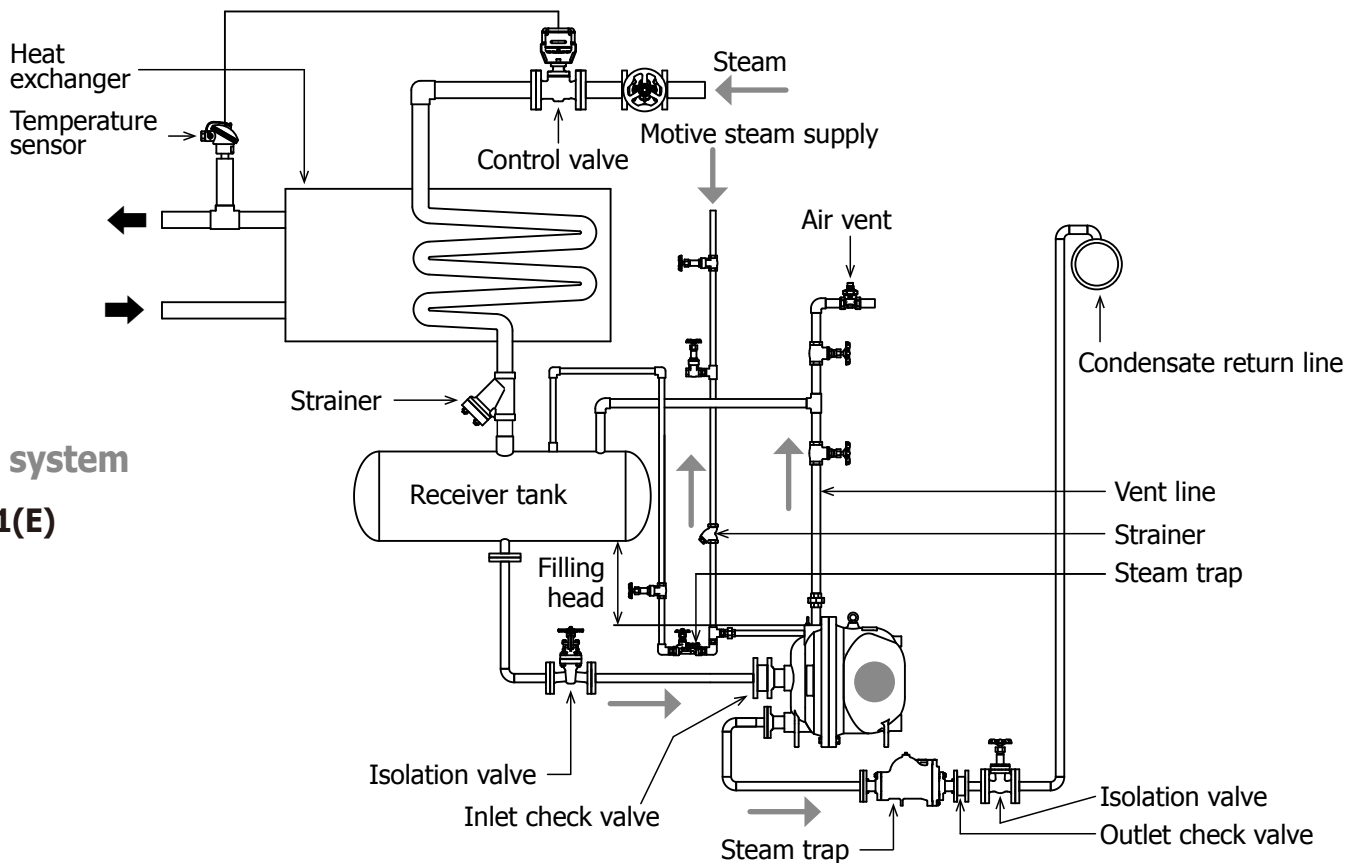

SERIES GL Spare Parts

GL11

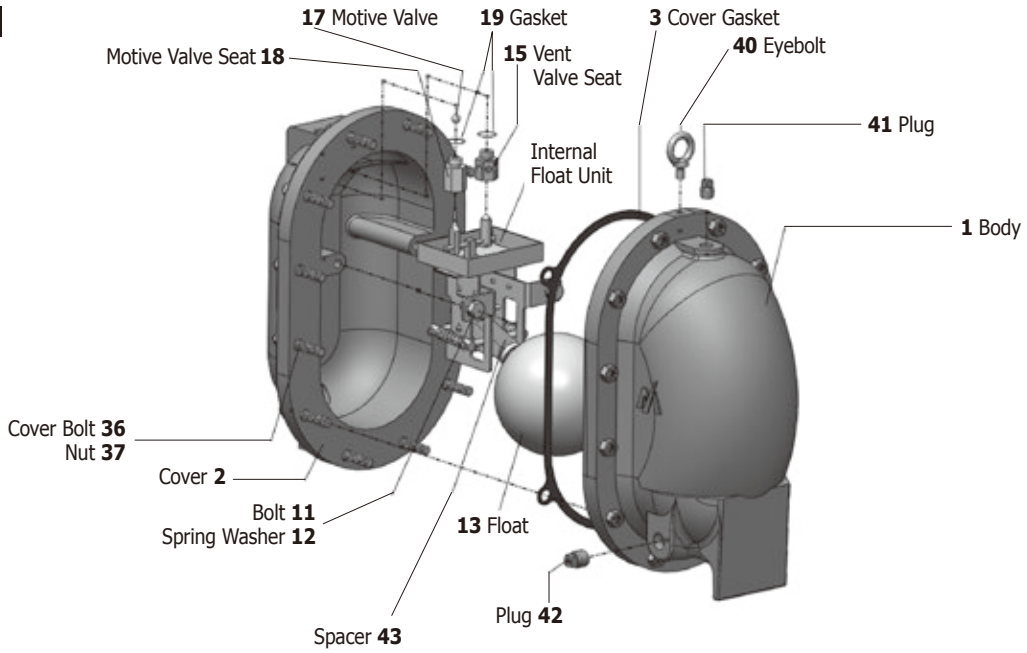

GLP81

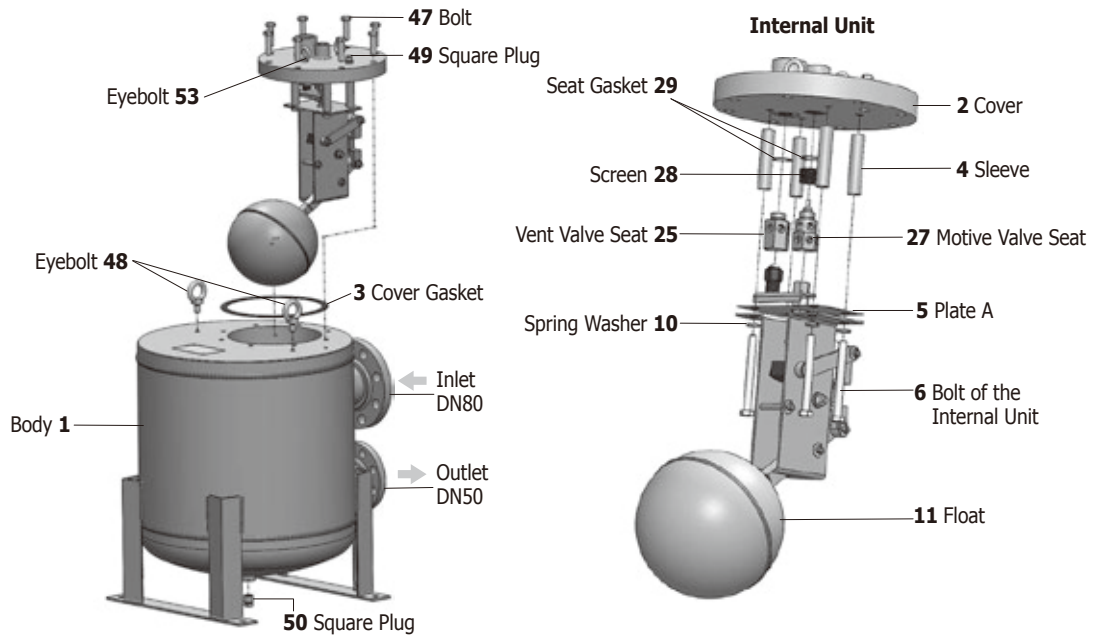

GL81

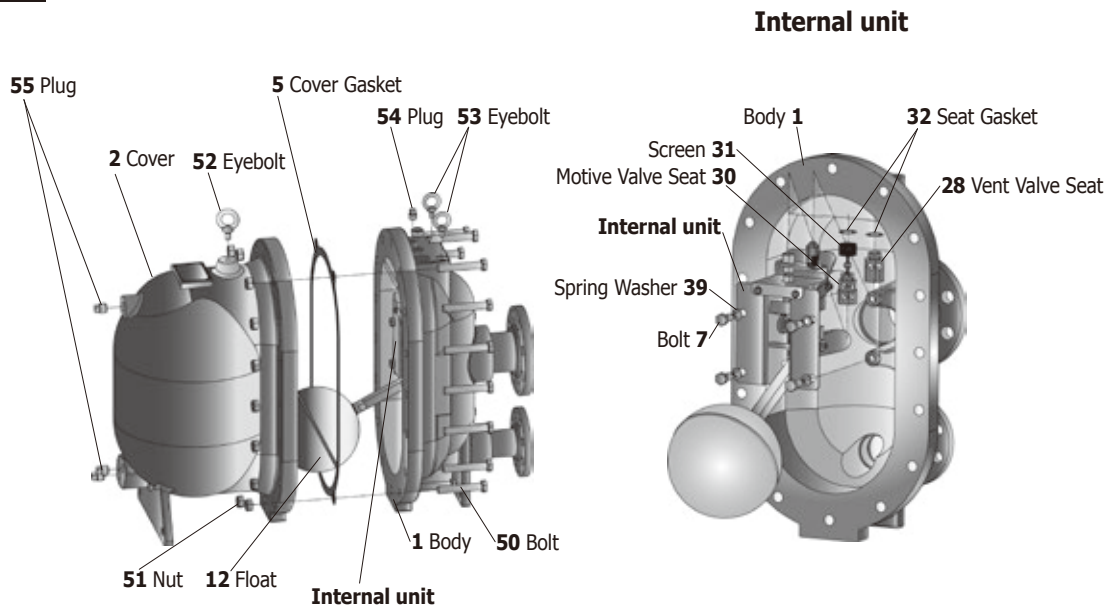

Air Traps

SERIES A

MIYAWAKI **Air Traps** are designed for discharge of condensate from air piping, receiver tanks, gas and compressed air systems.

Depending on the operating conditions and applications a wide range of various types of air traps is available. Most of the traps can be fitted with a pressure – balancing line to ensure air can escape from the trap body to prevent air locking. Pressure-balancing lines are usually not necessary, if the air trap is installed directly below the equipment to be drained or if the trap is installed vertically.

MIYAWAKI offers different seat materials and various body materials (including stainless steel) for draining special gas applications.

Models

AG11, AG12	Cast iron ball float air traps for medium condensate amounts
AGC1V	Stainless steel ball float air trap for small condensate loads (vertical installation)
AG29	Ductile cast iron ball float air and gas trap
AGH29	Cast steel ball float air and gas trap
AGU29	Stainless steel ball float air and gas trap
AGH12, AGH50	Cast Steel ball float air and gas trap
AE8	Ductile cast iron inverted bucket air trap
AV	Cast iron thermodynamic air trap with incorporated bypass

Installation Example

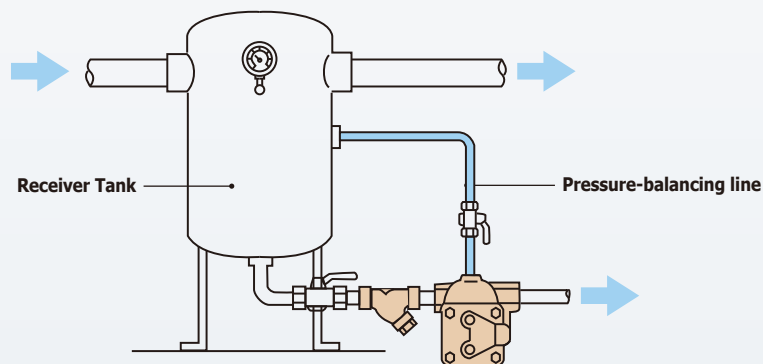

Operating principle

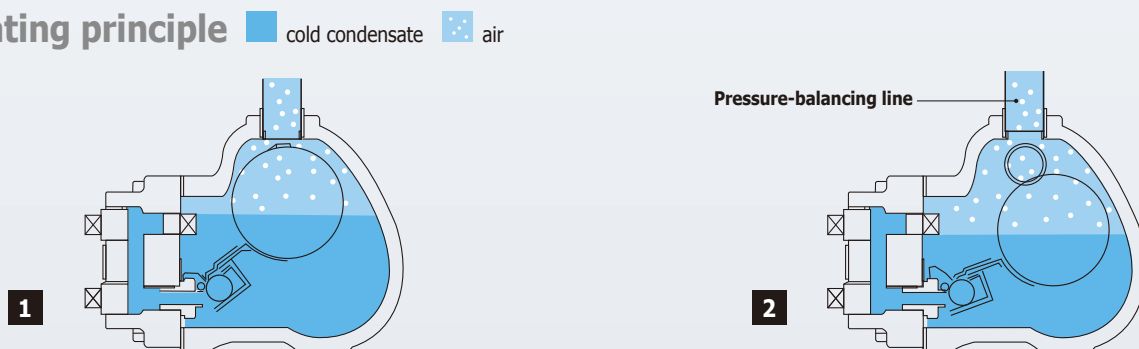

AG11, AG12

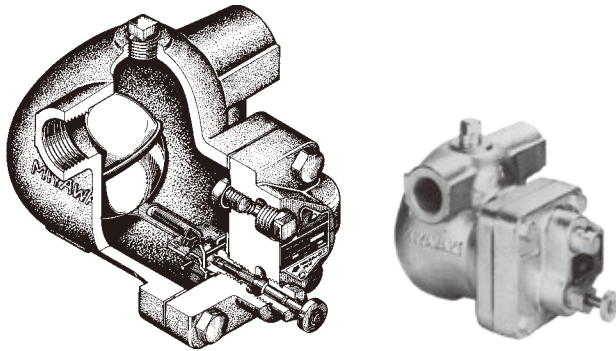

Capacity Chart AG11, AG12

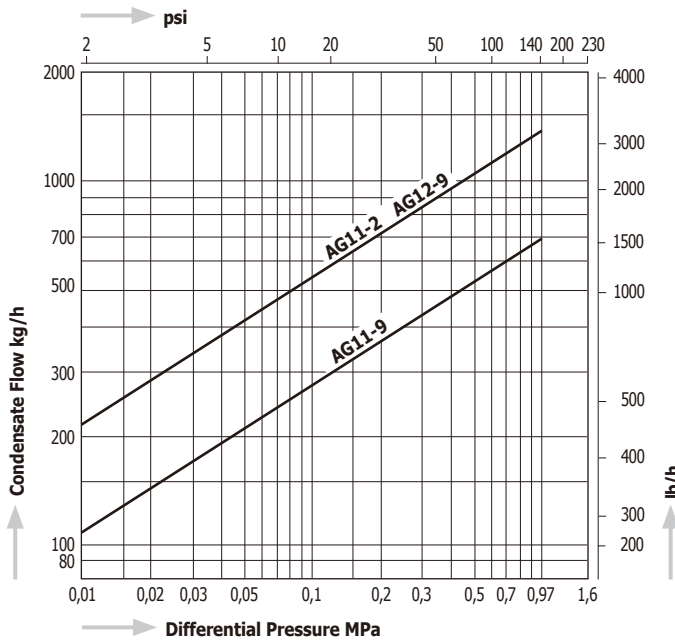

AGC1V

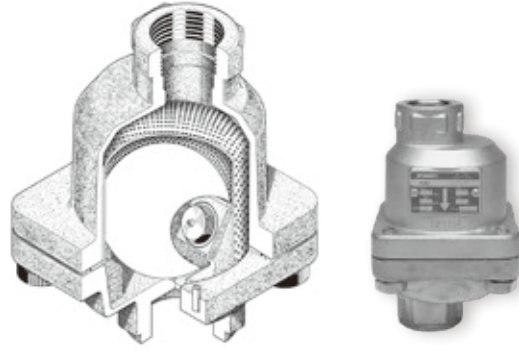

Capacity Chart AGC1V

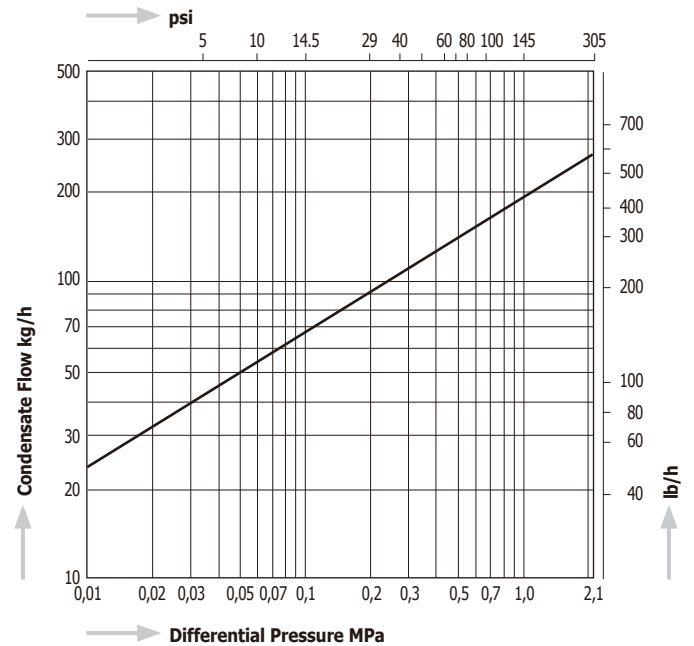

Dimensions AG11, AG12

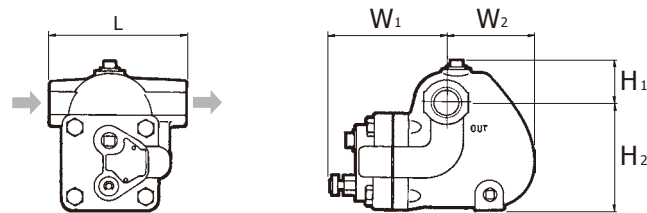

Dimensions

AGC1V, AGC1V-W

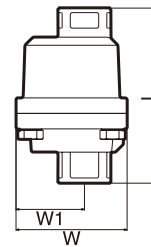

AGC1V-F

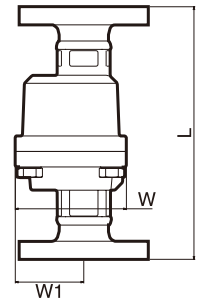

Model	Connections	Size	Max. Operating Pressure		Max. Operating Temperature		Dimensions (mm)						Dimensions (in)						Body Material	Weight	
			MPa	psig	°C	°F	L	H1	H2	W1	W2	W	L	H1	H2	W1	W2	W		kg	lb
AG11 - 2 AG12 - 9	Screwed Rc, NPT	1/2", 3/4"	0,2	29	100	212	120	37	92	121	60	-	4.7	1.5	3.6	4.8	2.4	-	Cast Iron FC250	3,9	8.6
		3/4", 1"	0,97	140			140	140	47	113	129	92	-	5.5	1.9	4.4	5.1	3.6		-	5,9
AGC1V	Screwed Rc, NPT	1/2"	2,1	305	350	662	127	-	-	53	-	86	5.0	-	-	2.1	-	3.4	Stainless Steel SCS13A	1,8	4.0
		3/4"					5.4						2.0							1,9	4.2
		1"					5.5						2.0							2,0	4.4
		127					5.0						2.1							1,8	4.0
AGC1V-W	Socket Weld JIS, ASME, DIN	1/2"	2,1	305	350	662	136	-	-	53	-	86	5.4	-	-	2.1	-	3.4	Stainless Steel SCS13A	1,9	4.2
		3/4"					5.5						2.0							2,0	4.4
		1"					5.5						2.0							2,0	4.4
AGC1V-F	Flanged JIS, ASME, DIN	1/2"	2,1	305	350	662	175	-	-	53	86	6.9	-	-	2.1	-	3.4	Stainless Steel SCS13A	3,3	7.3	
		3/4"					7.7					2.1							4,5	9.9	
		1"					8.5					2.0							5,3	11.7	
		195					7.7					2.1							4,5	9.9	
215	8.5	2.0	5,3	11.7																	

Horizontal version for AGC1V is available as special design. For more details, please contact MIYAWAKI Inc. or an authorized representative.

AE8

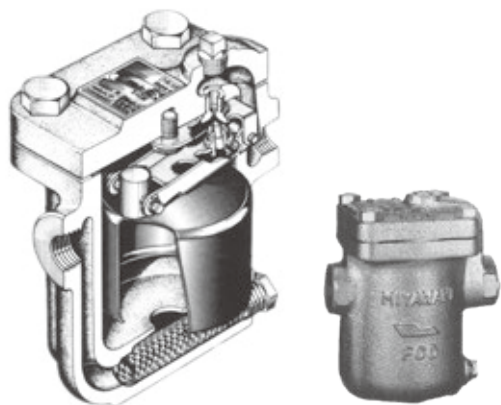

AV

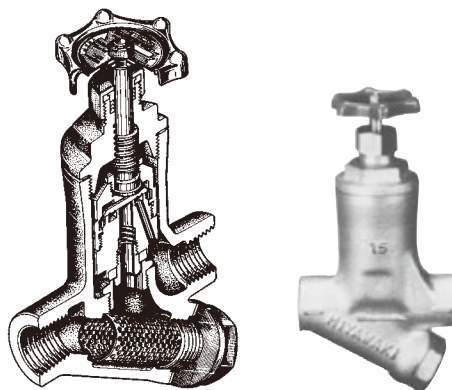

Capacity Chart AE8

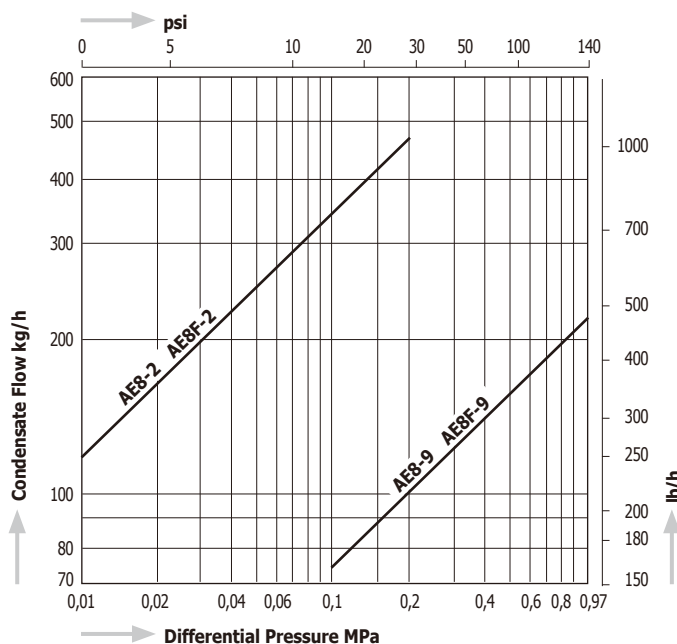

Capacity Chart AV

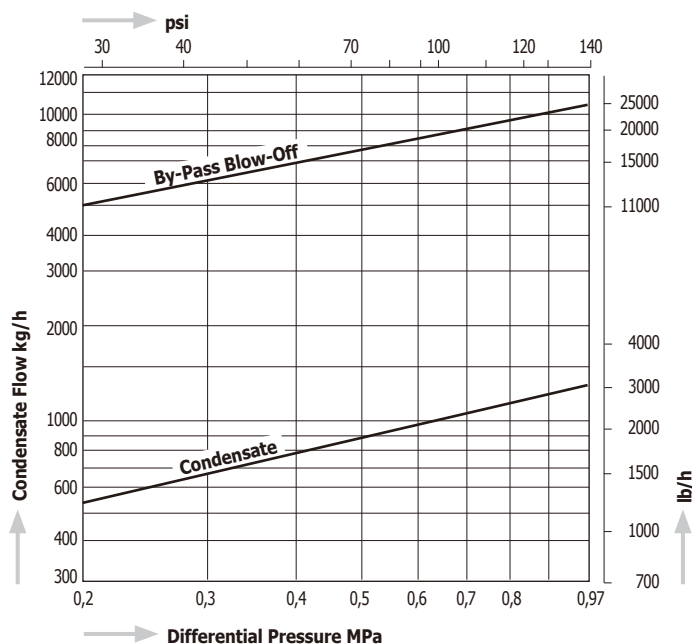

Dimensions

AE8

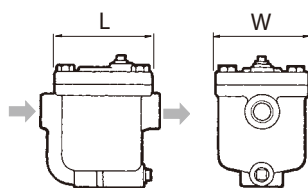

AE8F

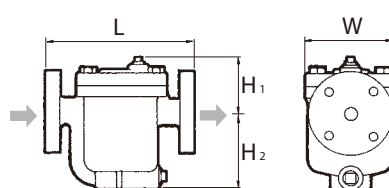

AV

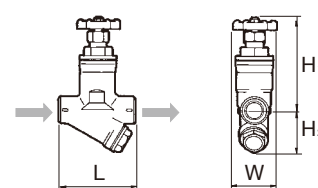

Model	Connections	Size	Max. Operating Pressure		Max. Operating Temperature		Dimensions (mm)				Dimensions (in)				Body Material	Weight	
			MPa	psig	°C	°F	L	H ₁	H ₂	W	L	H ₁	H ₂	W		kg	lb
AE8-2	Screwed Rc, NPT	1/2"	0,2	29	350	662	130	73	90	100	5.1	2.9	3.5	3.9	Ductile Cast Iron FCD450	3,7	8.1
		3/4"					135	5.3	3,9	8.6							
		1"					130	5.1	3,7	8.1							
		1/2"					135	5.3	3,9	8.6							
		3/4"					175	6.9	2.9	3.5	3,9					11.7	
AE8F-2	Flanged JIS, ASME, DIN	1/2"	0,2	29	350	662	195	68	95	100	7.7	2.7	3.7	3.9		5,7	12.5
		3/4"					215	8.5	6,8	15.0							
		1"					175	6.9	2.9	3.5	3,9					11.7	
		1/2"					195	7.7	2.7	3.7	3,9					12.5	
		3/4"					215	8.5	6,8	15.0							
AV-4	Screwed Rc, NPT	1/2"	0,97	140	150	302	110	60	65	65	4.3	6.1	2.6	2.6	Cast Iron FC250	2,4	5.3
		3/4"					120	65	70	4.7	2,5					5.5	
		1"					120	70	70	4.7	2,7					6.0	

AG29

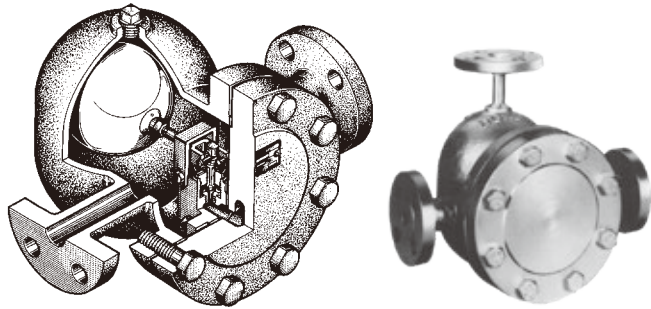

Capacity Chart AG29, AGH29, AGU29

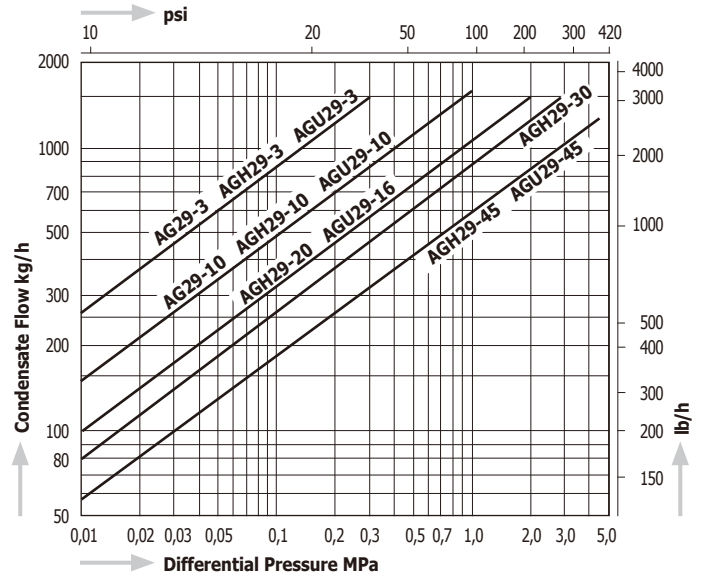

Dimensions

AG29, AGH29, AGU29

AGH29W, AGU29W

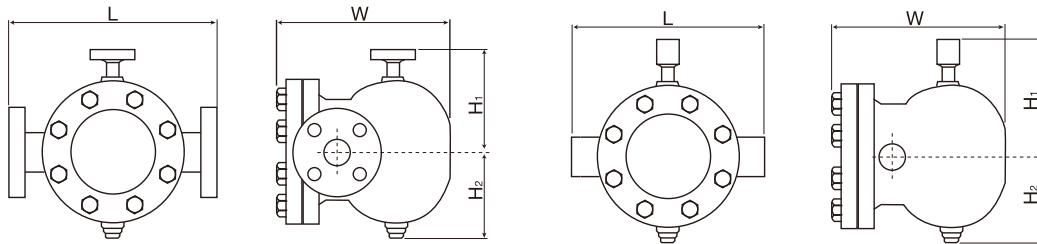

Model	Connections	Size	Max. Operating Pressure PMO		Max. Differential Pressure PMX		Max. Operating Temperature TMO		Dimensions (mm)				Dimensions (in)				Body Material	Weight			
			MPa	psig	MPa	psig	°C	°F	L	H ₁	H ₂	W	L	H ₁	H ₂	W		kg	lb		
AG29 - 3 10	Flanged JIS, ASME, DIN	½" - 1"	0,3	43	0,3	43	300	572	340	200	120	260	13.4	7.9	4.7	10.2	Ductile Cast Iron FCD450	26	57.2		
			1,0	145	1,0	145															
AGH29 - 3 10 20 30 45	Flanged JIS, ASME, DIN	½" - 2"	3,0	435	0,3	43	400	752	340 ½" - 1"	200	120	260	13.4 ½" - 1"	7.9	4.7	10.2	Cast Steel SCPH2	28,0*	61.6*		
					1,0	145												½" - 1"	½" - 1"		
					2,0	290												390	15.4	1 ¼" - 2"	1 ¼" - 2"
					3,0	435												1 ¼" - 2"	1 ¼" - 2"		
AGH29W - 3 10 20 30 45	Socket Weld JIS, ASME, DIN	½" - 1"	3,0	435	0,3	43	400	752	280	200	120	260	11.0	7.9	4.7	10.2	Cast Steel SCPH2	25,5	56.1		
					1,0	145															
					2,0	290															
					3,0	435															
AGU29 - 3 10 16 45	Flanged JIS, ASME, DIN	½" - 2"	3,0	435	0,3	43	400	752	340 ½" - 1"	200	120	260	13.4 ½" - 1"	7.9	4.7	10.2	Stainless Steel SCS13A	28,0*	61.6*		
					1,0	145												½" - 1"	½" - 1"		
					1,6	230												390	15.4	1 ¼" - 2"	1 ¼" - 2"
					4,5	652												4,5	652	1 ¼" - 2"	1 ¼" - 2"
AGU29W - 3 10 16 45	Socket Weld JIS, ASME, DIN	½" - 1"	3,0	435	0,3	43	400	752	280	200	120	260	11.0	7.9	4.7	10.2	Stainless Steel SCS13A	25,5	56.1		
					1,0	145															
					1,6	230															
					4,5	652														4,5	652

* The weight may differ depending on the size and flange standard.

AGH12, AGH50

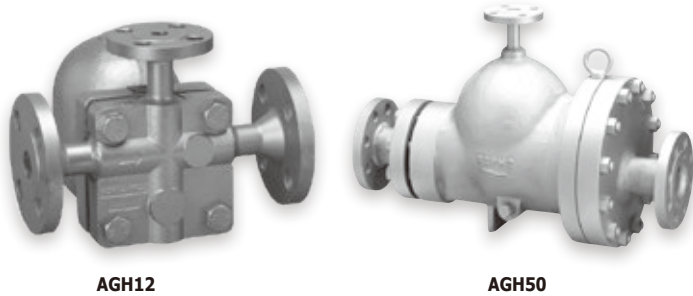

Capacity Chart AGH12-45

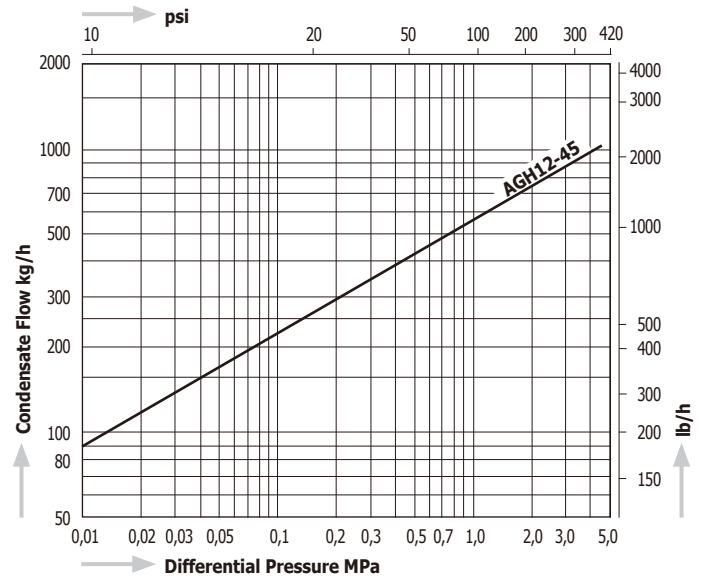

Dimensions

AGH12-45F

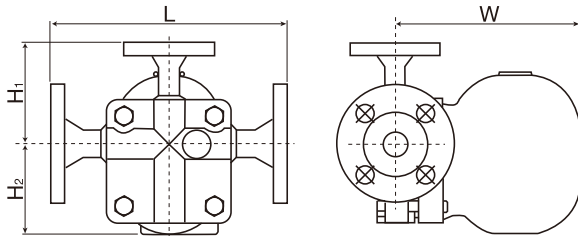

AGH12-45W

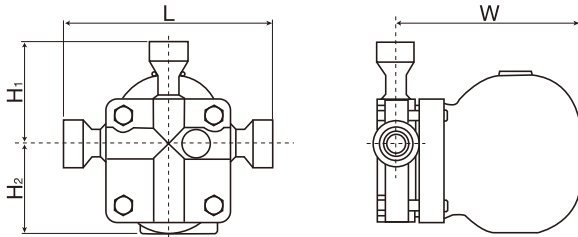

AGH50

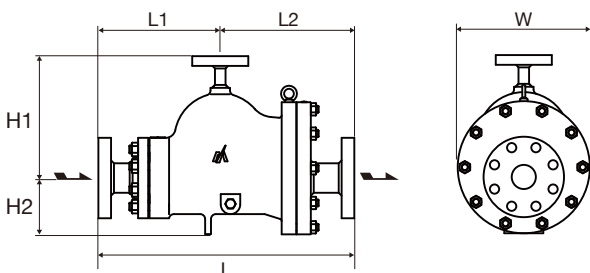

Capacity Chart AGH50

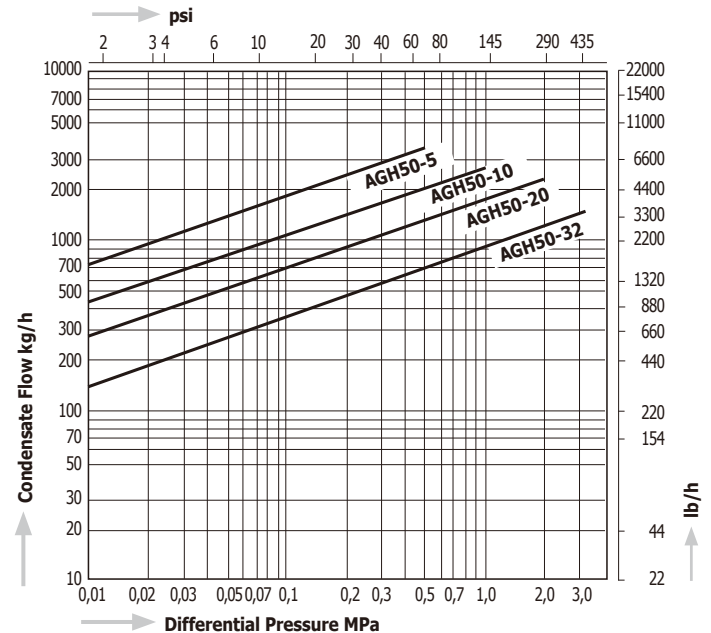

Table 1: Dimensions L and Weight

Model	Size	ASME Class* (#150, #300)							
		Dimensions* (mm)			Dimensions* (in)			Weight*	
		L	L ₁	L ₂	L	L ₁	L ₂	kg	lb
AGH50	2"	525	250	275	20.7	9.8	10.8	64	140.8
	2½"	550	265	285	21.7	10.4	11.2	68	149.6
	3"	555		290	21.9	10.4	11.4	72	158.4
	4"	590	285	305	23.2	11.2	12.0	73 / 82	160.6 / 180.4

Model	Connections	Size	Max. Operating Pressure, PMO		Max. Differential Pressure, PMX		Max. Operating Temperature, TMO		Dimensions* (mm)				Dimensions* (in)				Body Material	Weight*	
			MPa	psig	MPa	psig	°C	°F	L	H ₁	H ₂	W	L	H ₁	H ₂	W		kg	lb
AGH12 - 45F	Flanged JIS, ASME, DIN	½" - 1"	4,5	652	4,5	652	425	800	250	107	95	195	9.8	4.2	3.7	7.7	Cast Steel SCPH2	17	37.4
AGH12 - 45W	Socket Weld JIS, ASME, DIN												220					75	8.7
AGH50 -	Flanged JIS, ASME, DIN	2" - 4"	3,2	464	0,5	72.5	400	752	Table 1	250	115	270	Table 1	9.8	4.5	10.6	Cast Steel SCPH2	Table 1	
					1,0	145													
					2,0	290													
					3,2	464													

* Depending on the flange standard the face-to-face dimensions and the weight may differ.

Stainless Steel as body material is available as special design. For more details, please contact MIYAWAKI Inc. or an authorized representative.

AG11/AG12

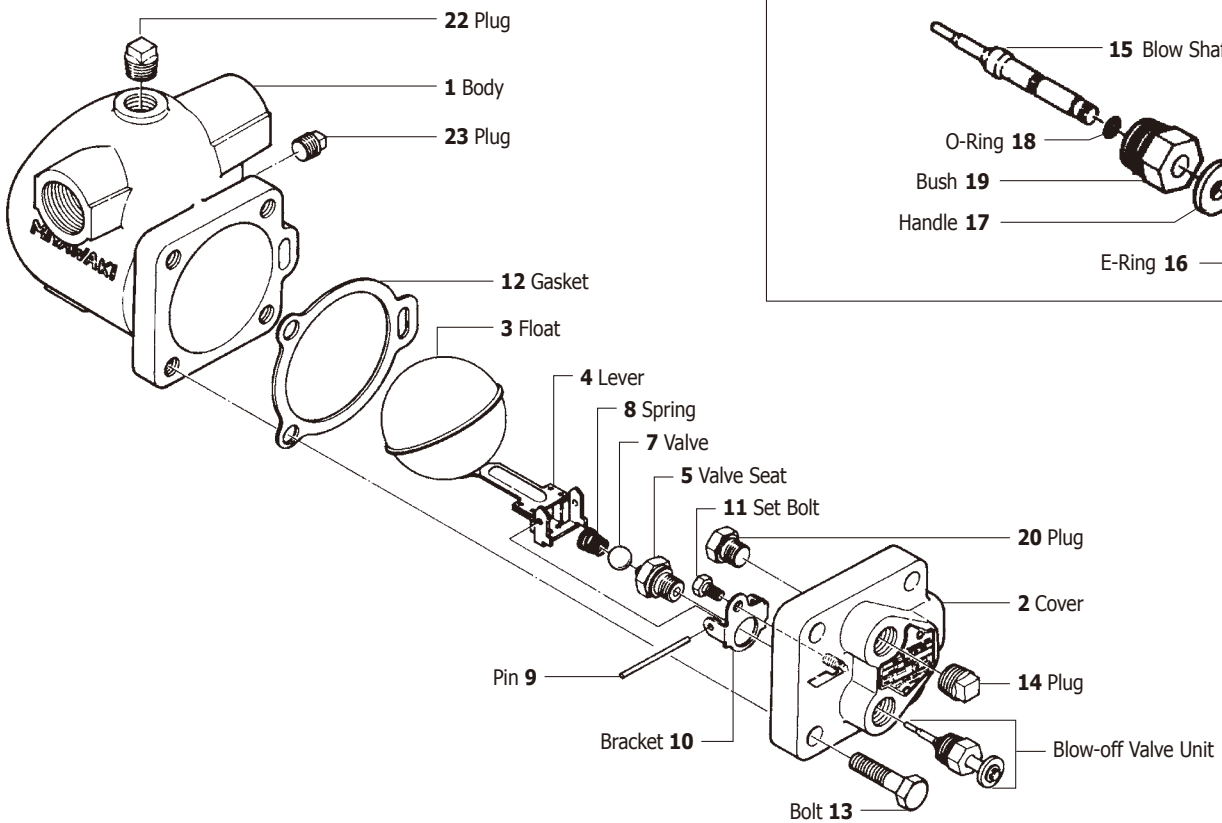

Blow-off Valve Unit

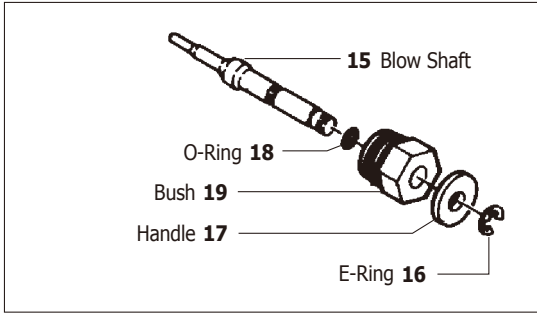

AGC1V

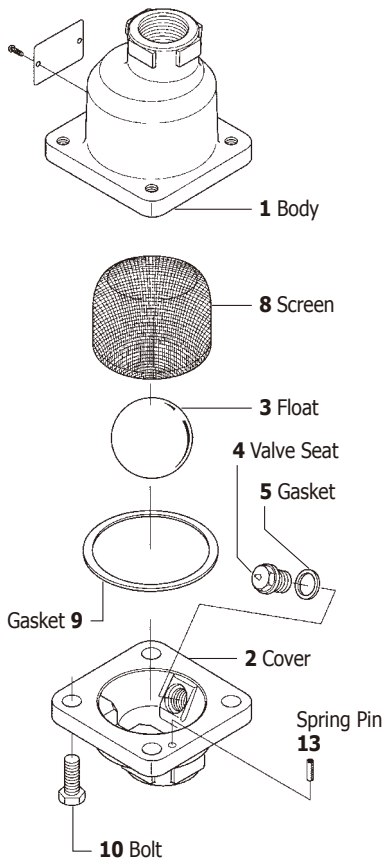

AE8

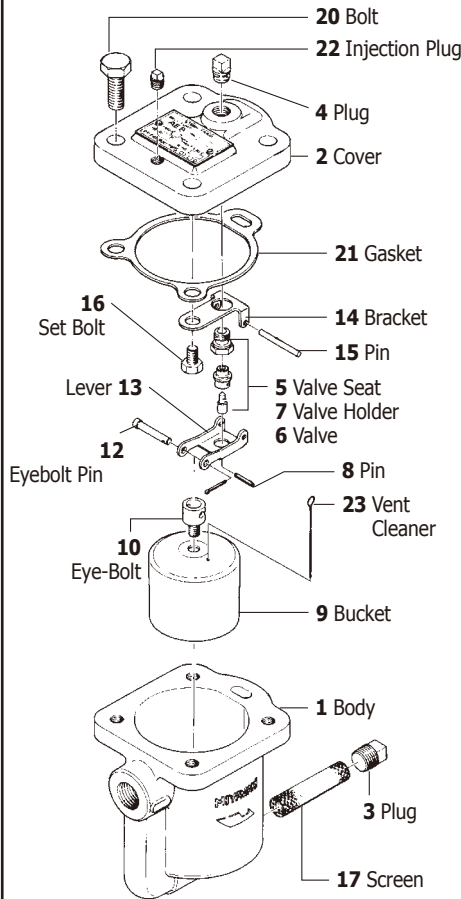

AV

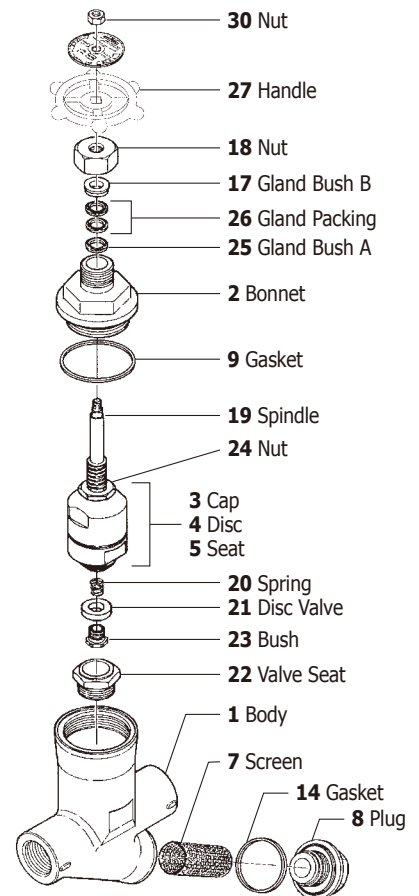

AG29, AGH29, AGU29

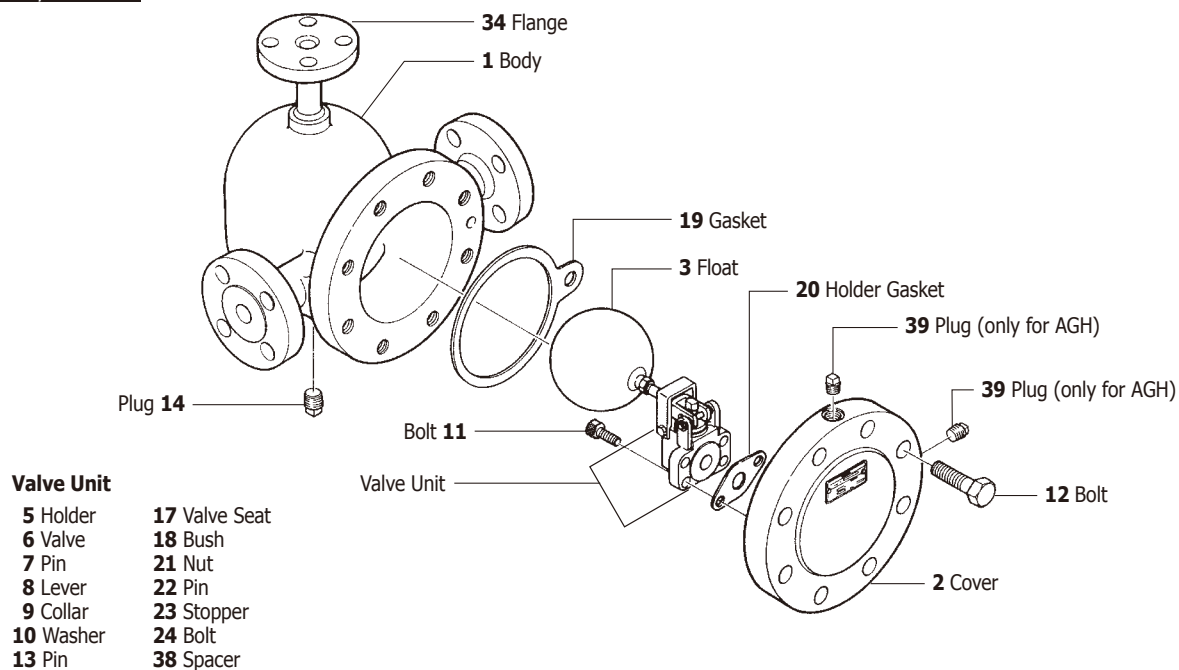

AGH12

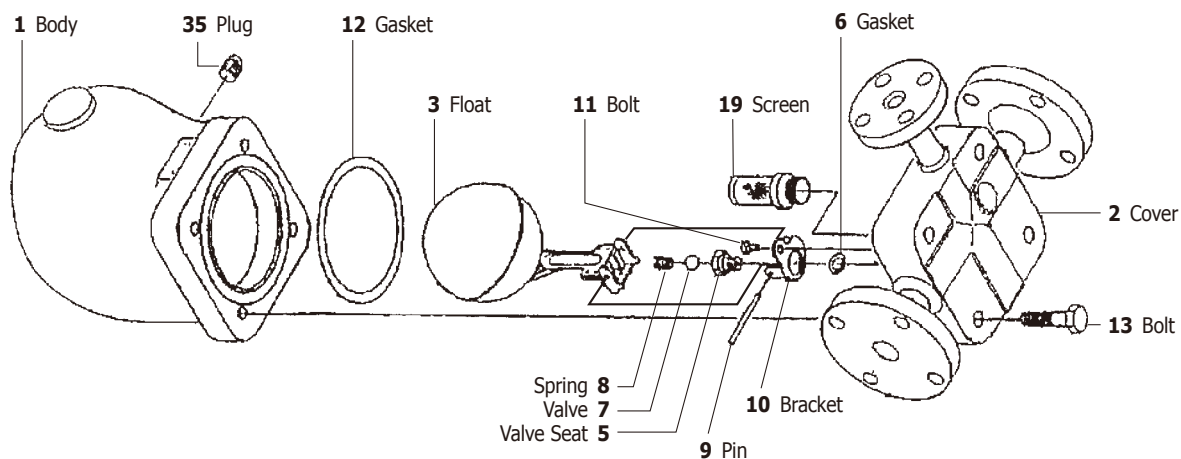

AGH50

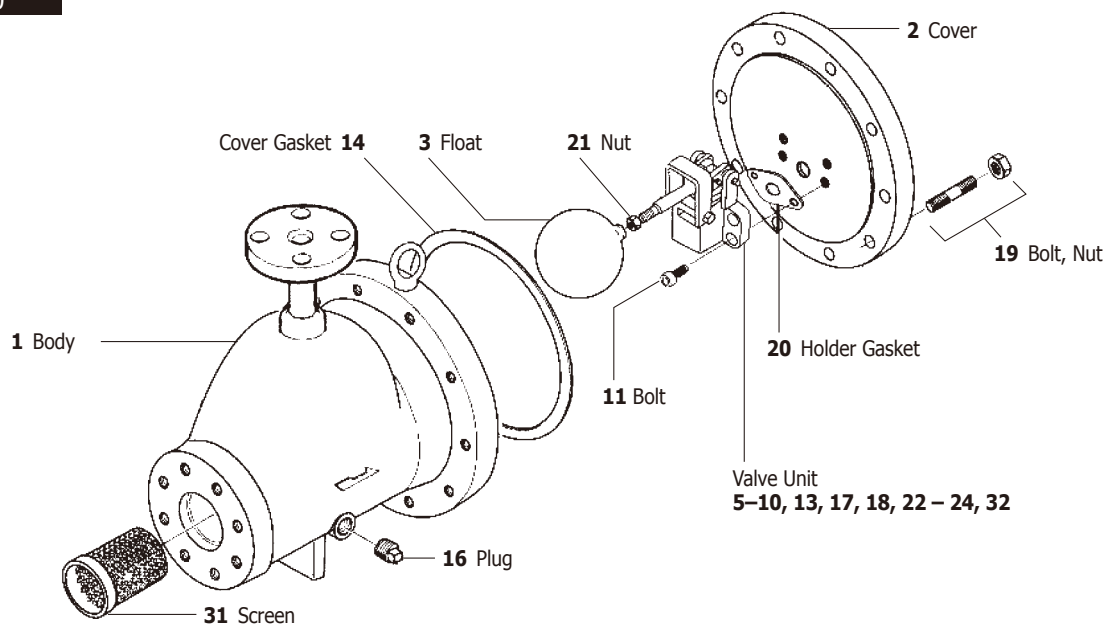

Air Vents

SERIES AT, AD, AW

MIYAWAKI **Air vents** are used to remove air and gases from pipelines for steam and liquids, boilers and other special equipment.

MIYAWAKI offers a wide range of thermostatic air vent. They ensure the efficiency of the system by removing the air and gases accumulated during operation and system downtime.

Air vents must be installed at the highest point of the equipment/ system section to be vented.

Models

- AW** Thermostatic air vents made of brass
- AT7N, AT9N** Forged steel, with bimetal and with the ability to adjust the temperature of the exhaust gas-air mixture for equipment with low and medium pressure
- ADC1, ADL1** Stainless steel thermostatic air vents
- AT51** Forged steel, with the ability to adjust the temperature of the exhaust gas mixture for high pressure equipment

Installation Example

Open boiler

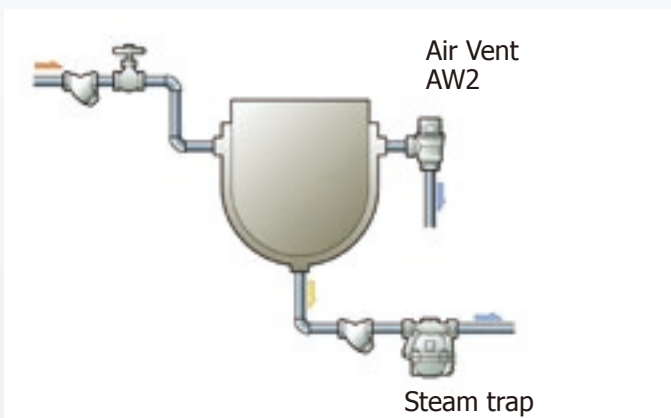

Autoclave

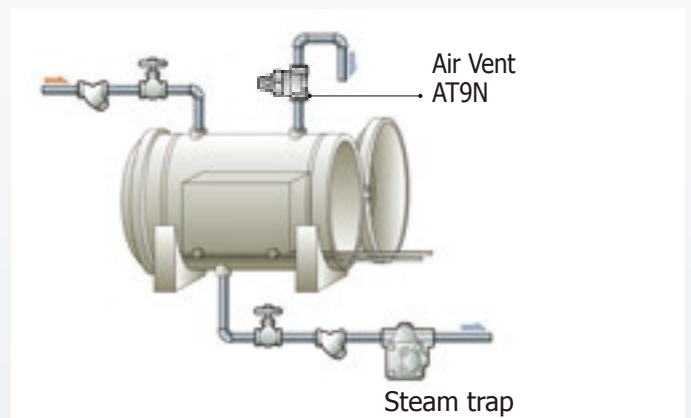

Drum dryer

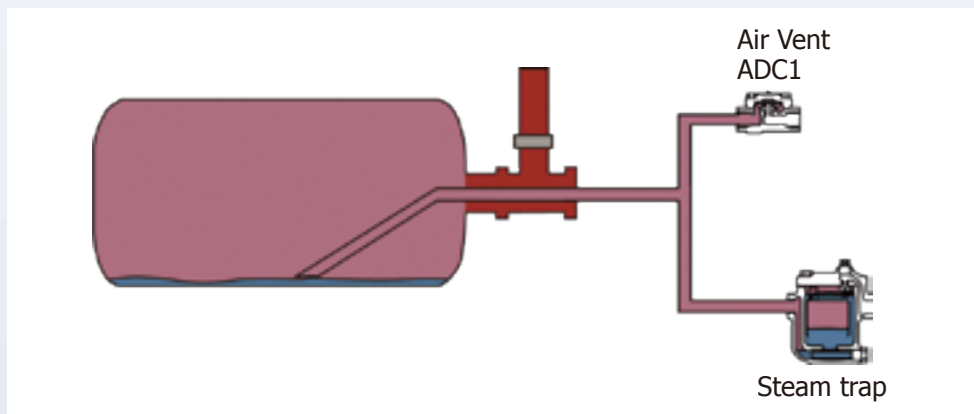

AW2

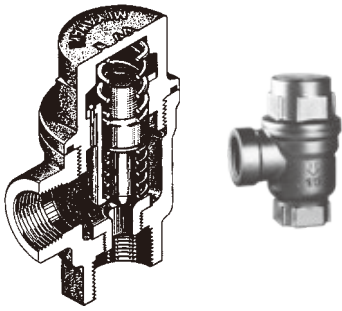

AT7N

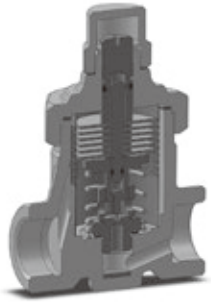

AT9N

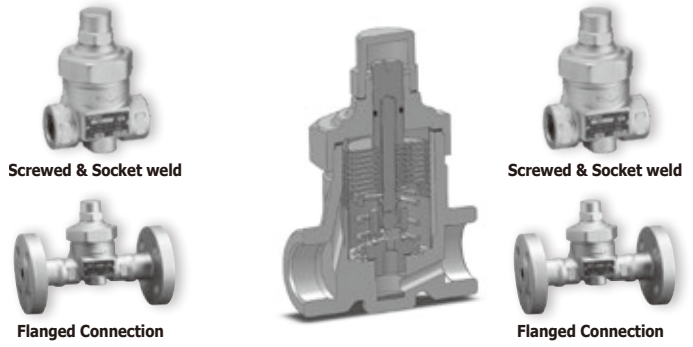

Dimensions

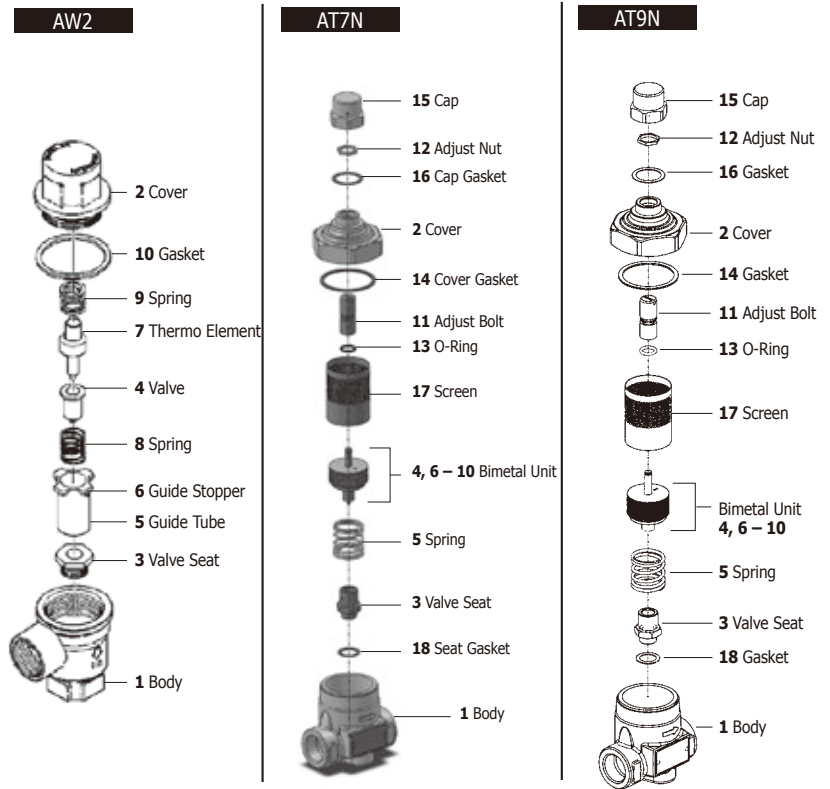
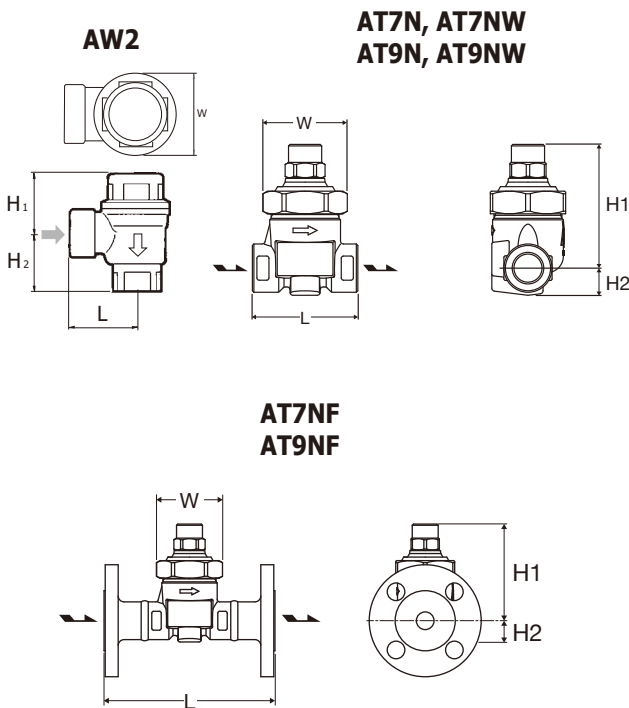

Model	Connections	Size	Max. Operating Pressure		Max. Operating Temperature		Dimensions (mm)				Dimensions (in)				Body Material	Weight	
			MPa	psig	°C	°F	L	H1	H2	W	L	H1	H2	W		kg	lb
AW2-5	Screwed Rc, NPT	1/2"	0,5	73	160	320	35	42	35	41	1.4	1.7	1.4	1.6	Brass C3771	0,4	0.9
		3/4"					41	41	1.6	1.6	0,5	1.1					
AT7N	Screwed Rc, NPT	1/2"	2,1	305	350	662	70		18		2.8		0.7		Forged Steel A105	0,9	2.0
		3/4"					80	82	19	56	3.2	3.2	0.8	2.2		1,0	2.2
		1"							23		0.9		1,1	2.4			
AT7NW	Socket Weld JIS, ASME, DIN	1/2"	2,1	305	350	662	70		18		2.8		0.7		Forged Steel A105	0,9	2.0
		3/4"					80	82	19	56	3.2	3.2	0.8	2.2		1,0	2.2
		1"							23		0.9		1,1	2.4			
AT7NF	Flanged JIS, ASME, DIN	1/2"	2,1	305	350	662	145*	82	18		5.7*	3.2	0.7		Forged Steel A105	2,6	5.7
		3/4"						19	56	3.2	3.2	0.8	2.2	3,4		7.5	
		1"						23		0.9		4,0	8.8				
AT9N	Screwed Rc, NPT	1/2"	1,6	230	350	662	70		18		2.8		0.7		Forged Steel A105	0,9	2.0
		3/4"					80	82	19	56	3.2	3.2	0.8	2.2		1,0	2.2
		1"							23		0.9		1,1	2.4			
AT9NW	Socket Weld JIS, ASME, DIN	1/2"	1,6	230	350	662	70		18		2.8		0.7		Forged Steel A105	0,9	2.0
		3/4"					80	82	19	56	3.2	3.2	0.8	2.2		1,0	2.2
		1"							23		0.9		1,1	2.4			
AT9NF	Flanged JIS, ASME, DIN	1/2"	1,6	230	350	662	145*	82	18		5.7*	3.2	0.7		Forged Steel A105	2,6	5.7
		3/4"						19	56	3.2	3.2	0.8	2.2	3,4		7.5	
		1"						23		0.9		4,0	8.8				

*On request also available with different face-to-face length

ADC1

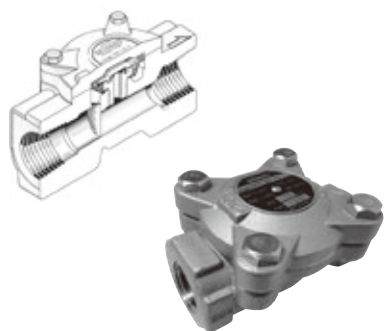

ADL1

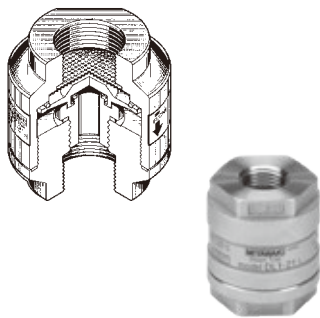

Dimensions

ADC1

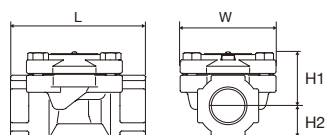

ADC1-F

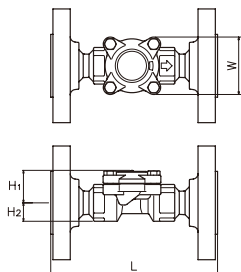

ADL1

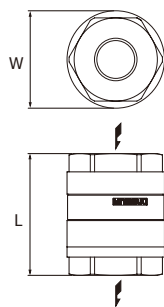

ADC1

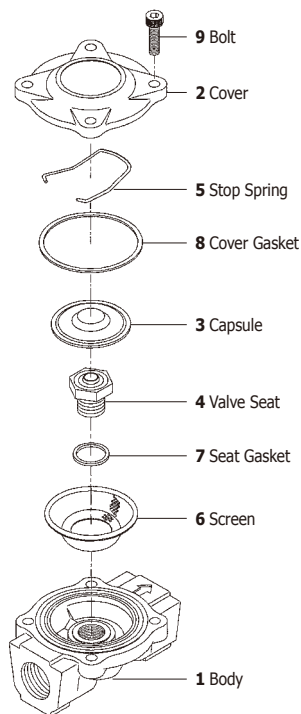

ADL1

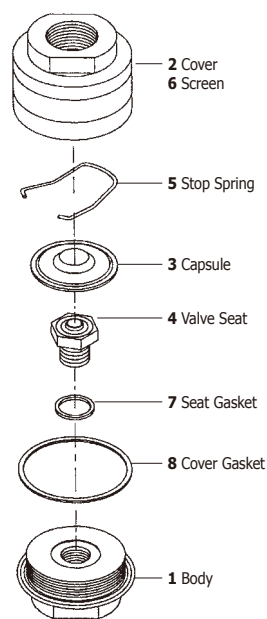

Model	Connections	Size	Max. Operating Pressure		Max. Operating Temperature		Dimensions (mm)				Dimensions (in)				Body Material	Weight	
			MPa	psig	°C	°F	L	H ₁	H ₂	W	L	H ₁	H ₂	W		kg	lb
ADC1-21H ADC1-21L	Screwed Rc, NPT	1/4", 3/8"	2,1	305	220	428	65	29	11	53	2.6	1.1	0.4	2.1	Stainless Steel SCS13A	0,4	0.9
		1/2", 3/4"					75	31	17		3.0	1.2	0.7			0,5	1.1
1"	80	34					21	3.1	1.3		0.8	1,3	2.9				
ADC1-21HF ADC1-21LF	Flanged JIS, ASME, DIN	1/2"					150	31	17		5.9	1.2	0.7			2,2	4.9
		3/4"					160	34	21		6.3	1.3	0.8			3,1	6.8
ADL1-21H ADL1-21L	Screwed Rc, NPT	1/4"	2,1	305	220	428	60	48	2.4	1.9	Stainless Steel SCS13	0,7	1.5				
		3/8"															
		1/2"															
		3/4"															
ADL1-10C	Screwed Rc, NPT	1/4"	1,0	145	220	428	60	48	2.4	1.9	0,7	1.5					
		3/8"															
		1/2"															
		3/4"															
		1"															

AT51

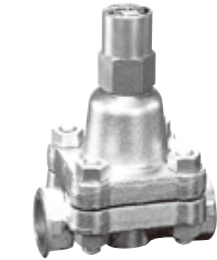
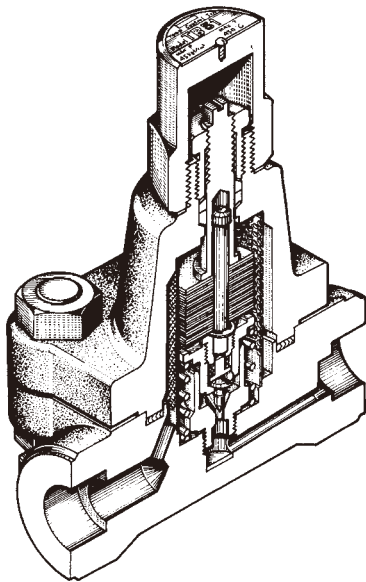

Screwed & Socket Weld



Flanged

AT51

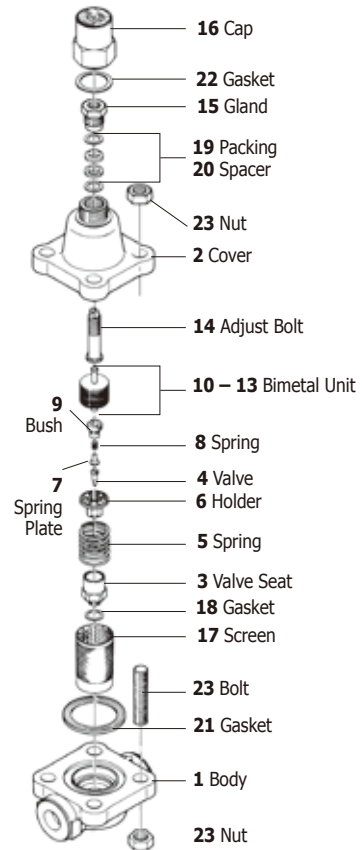

Dimensions

AT51 / AT51W

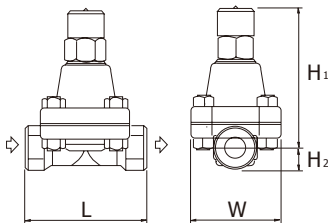

AT51F

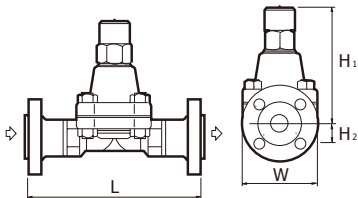

Table 1: Face-to-face dimensions / weights

Size	JIS 20 K				JIS 30 K				JIS 40 K				JIS 63 K			
	mm	in	kg	lb	mm	in	kg	lb	mm	in	kg	lb	mm	in	kg	lb
½"	200	7.9	7,3	16.1	200	7.9	8,4	18.5	200	7.9	8,7	19.2	220	8.7	9,6	21.2
¾"	210	8.3	7,7	17.0	210	8.3	8,9	19.6	210	8.3	9,2	20.3	230	9.1	11,1	24.5
1"	240	9.5	9,2	20.3	240	9.5	10,1	22.3	240	9.5	10,5	23.2	240	9.5	12,1	26.7

Size	ASME 150 lb				ASME 300 lb				ASME 600 lb				ASME 900 lb			
	mm	in	kg	lb	mm	in	kg	lb	mm	in	kg	lb	mm	in	kg	lb
½"	200	7.9	6,7	14.8	200	7.9	7,2	15.9	200	7.9	7,3	16.1	220	8.7	9,6	21.2
¾"	210	8.3	7,7	17.0	230	9.1	8,2	18.1	230	9.1	8,5	18.7	230	9.1	10,9	24.0
1"	240	9.5	8,3	18.3	240	9.5	9,4	20.7	240	9.5	9,6	21.2	240	9.5	13,3	29.3

Size	DIN PN10 - PN40				DIN PN63 / PN100			
	mm	in	kg	lb	mm	in	kg	lb
DN15	210	8.3	9,4	20.7	210	8.3	9,4	20.7
DN20	230	9.1	11,4	25.1	230	9.1	11,4	25.1
DN25	230	9.1	12,5	27.6	230	9.1	12,5	27.6

Model	Connections	Size	Max. Operating Pressure		Max. Operating Temperature		Dimensions (mm)				Dimensions (in)				Body Material	Weight		
			MPa	psig	°C	°F	L	H ₁	H ₂	W	L	H ₁	H ₂	W		kg	lb	
AT51	45 65	Screwed Rc, NPT	½" - 1"	4,5	653	425	800	130	155	25	100	5.1	6.1	1.0	3.9	Forged Steel A105	5,7	12.6
				6,5	943													
AT51W	45 65	Socket Weld JIS, ASME, DIN	½" - 1"	4,5	653													
				6,5	943													
AT51F	45 65	Flanged JIS, ASME, DIN	½" - 1"	4,5	653			Table 1	155	25	100	Table 1	6.1	1.0	3.9		Table 1	Table 1
				6,5	943													

Pressure Reducing Valves

SERIES RE

Pressure Reducing Valves (PRV) are designed for regulating the downstream pressure and maintaining it within certain acceptable limits. Ideally, a PRV should provide constant downstream pressure while delivering the required flow, i.e. the PRV automatically adjusts the steam flow to meet the downstream system demand. Depending on the model, MIYAWAKI's pressure reducing valves are designed for steam, air, gases and liquids. MIYAWAKI is manufacturing three types of PRV:

- Direct acting pressure reducing valves
- Pilot operated pressure reducing valves
- Pressure reducing valves with a downstream pressure sensing line (pulse line)

Operating principle General

Direct Acting PRV

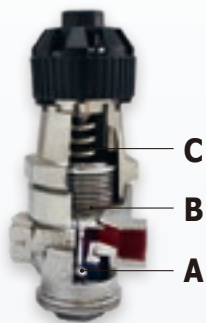

The direct acting PRV has 3 essential elements:
 A Main Valve Unit
 B Pressure Measuring Element (Bellows)
 C Adjust Spring

Changes in downstream pressure are sensed by the bellows, which expands or contracts depending on the pressure change. The movement of the bellows will be directly transferred to the spring, which will open or close the main valve, thus keeping the downstream pressure at a certain level.

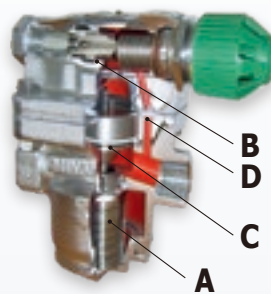

Pilot Operated PRV

The pilot operated PRV has 4 essential elements:
 A Main Valve Unit
 B Pilot Valve (same structure as the direct-acting PRV)
 C Adjusting Unit (piston and cylinder liner)
 D Downstream pressure sensing line (pulse line)

Changes in downstream pressure are sensed by the pilot valve mechanism (bellows connected with a pilot valve unit) through a signal line D, which connects the pilot valve regulator with the secondary pressure side. Movement of the bellows will open or close the pilot valve, regulating the amount of steam influencing the movement of the piston, which will close or open the main valve, thus keeping downstream pressure on a stable level.

Pilot operated pressure reducing valves are used to improve accuracy and capacity, compared with direct acting pressure regulators. The decision whether to use a direct acting valve or a pilot operated valve depends on the demands of the steam using system.

Operating principle Pilot operated PRV

■ Inlet Steam Pressure
 ■ Secondary Steam Pressure
 ■ Adjusting Steam Pressure

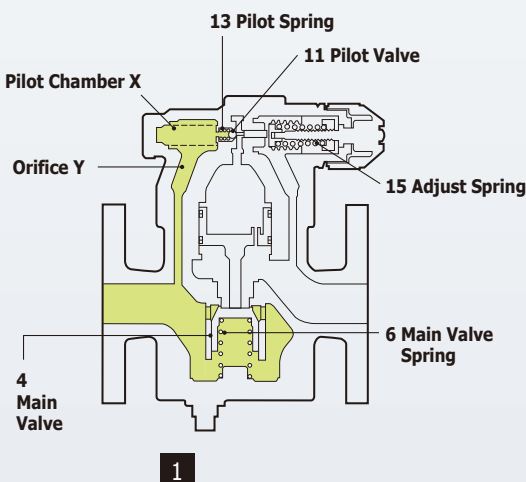

Before adjusting the secondary pressure the green handle must be turned clockwise to release the adjust spring (15) until the handle moves freely. In this position the main valve (4) is closed by the force of the spring (6) and the pilot valve (11) is closed by the force of the spring (13). When steam enters the valve, part of the steam enters the pilot chamber (X) through the orifice (Y).

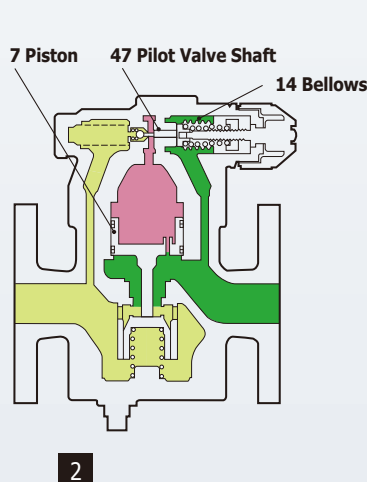

To adjust the secondary pressure the handle must be turned counterclockwise. As a result, the adjust spring (15) will be pressed into the bellows (14). The bellows will expand and the pilot valve shaft (47) will open the pilot valve (11). The steam, which has entered the pilot chamber (X) will flow through the pilot valve unit into the chamber above the piston (7). Due to the steam pressure the piston (7) will move downwards and open the main valve (4). Steam will flow towards the secondary side.

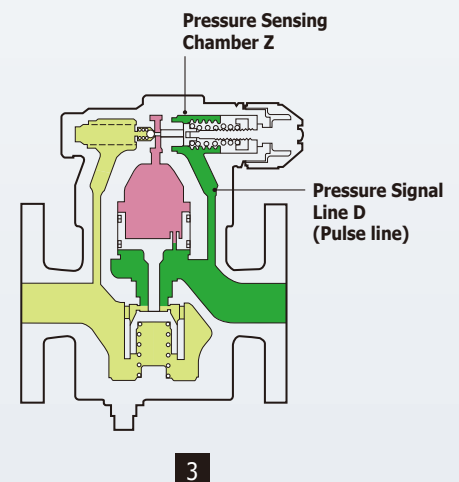

Part of the steam, which flows to the secondary side will enter the pressure sensing chamber (Z) through the pressure signal line (D). Due to the pressure influence, the bellows (14) will contract. Depending on the secondary pressure value the force exerted by the bellows and the force exerted by the adjust spring (15) will be balanced and the opening degree of the pilot valve (11) will be adjusted, thus regulating the amount of steam flowing through the pilot valve to the piston. Consequently, the opening degree of the main valve (4) will be also adjusted to regulate the steam flow in the direction of the secondary side maintaining a stable steam flow and steam pressure on the secondary side.

RE1

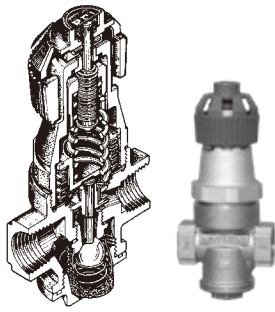

Capacity Chart RE1, RE1-4

Minimum Differential Pressure:
0,04 MPa (5.8 psig)

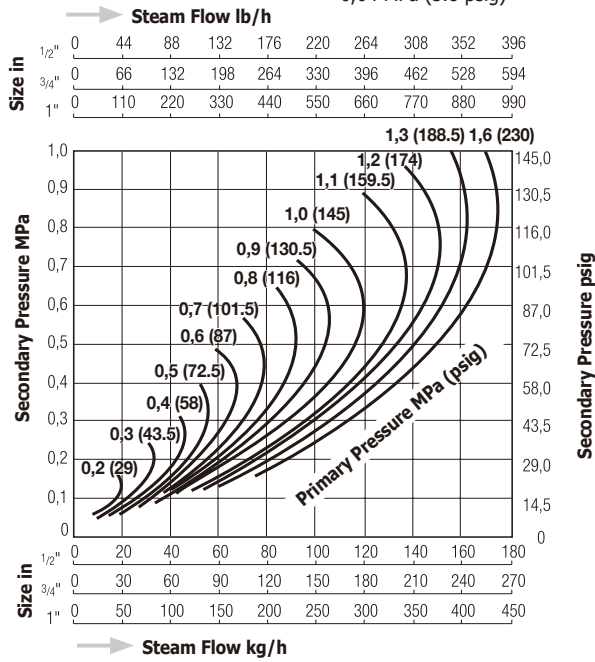

RE2

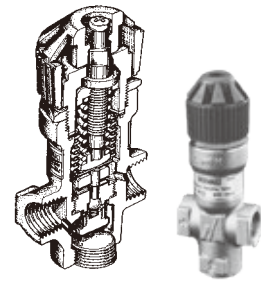

Capacity Chart RE2

Minimum Differential Pressure:
0,05 MPa (7.3 psig)

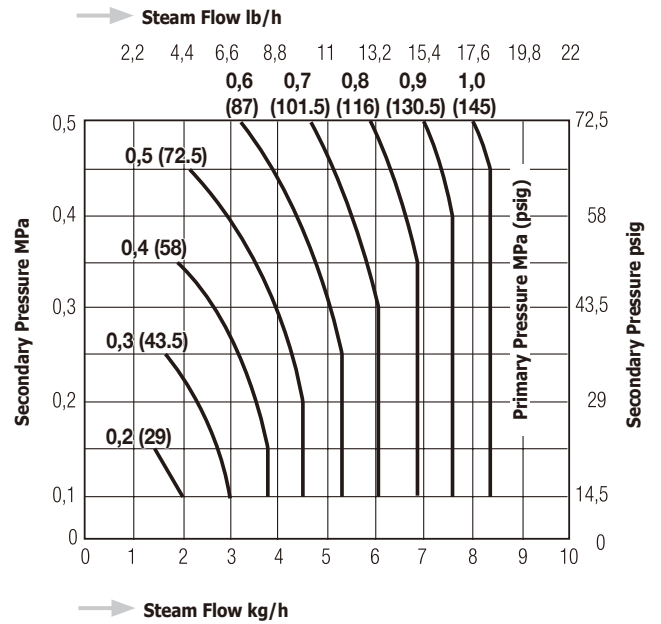

Capacity Chart RE1-2

Minimum Differential Pressure:
0,05 MPa (7.3 psig)

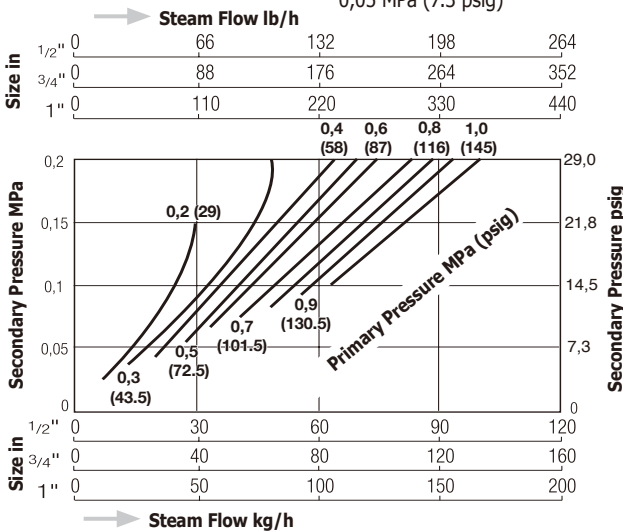

Dimensions RE1

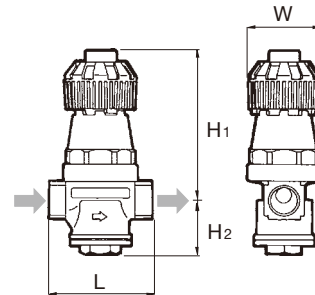

Dimensions RE2

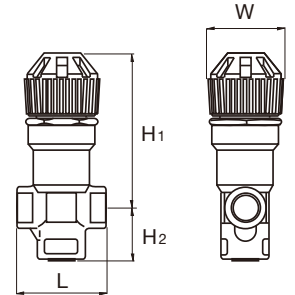

Cv Values	Size (in)	RE1 & RE1-4	RE1-2	Kvs Values	Size (in)	RE1 & RE1-4	RE1-2
	1/2"	1,2	1,9		3,2	1/2"	1,0
3/4"	1,9	1,9	3,5	3/4"	1,6	1,6	
1"	3,2	2,1	4,1	1"	2,8	1,8	

Model	Connection	Size (in)	Operating Pressure (Primary)		Secondary Pressure		Max. Red. Pressure Ratio	Max. Operating Temperature		Dimensions (mm)				Dimensions (in)				Body Material	Weight	
			MPa	psig	MPa	psig		°C	°F	L	H1	H2	W	L	H1	H2	W		kg	lb
RE1	Screwed Rc, NPT	1/2"	0,2 - 1,6	29 - 230	0,05 - 1,0	7,3 - 145	10 : 1	204	399	80	137	46	65	3,2	5,4	1,8	2,6	Brass C3771	1,4	3,1
		90								137	46	65	3,5	5,4	1,8	2,6	1,6		3,5	
		105								144	58	65	4,1	5,7	2,3	2,6	1,9		4,2	
RE1-4	Screwed Rc, NPT	1/2"	0,2 - 1,0	29 - 145	0,05 - 0,4	7,3 - 58	10 : 1	204	399	80	137	46	65	3,2	5,4	1,8	2,6	Brass C3771	1,4	3,1
		90								137	46	65	3,5	5,4	1,8	2,6	1,6		3,5	
		105								144	58	65	4,1	5,7	2,3	2,6	1,9		4,2	
RE1-2	Screwed Rc, NPT	1/2"	0,2 - 1,0	29 - 145	0,02 - 0,2	2,9 - 29	10 : 1	204	399	80	137	46	65	3,2	5,4	1,8	2,6	Brass C3771	1,4	3,1
		90								137	46	65	3,5	5,4	1,8	2,6	1,6		3,5	
		105								144	58	65	4,1	5,7	2,3	2,6	1,9		4,2	
RE2	Screwed Rc, NPT	3/8"	0,2 - 1,0	29 - 145	0,1 - 0,5	14 - 72	10 : 1	184	363	50	89	31	43	2,0	3,5	1,2	1,7	0,56	1,2	

REC1

Capacity Chart REC1

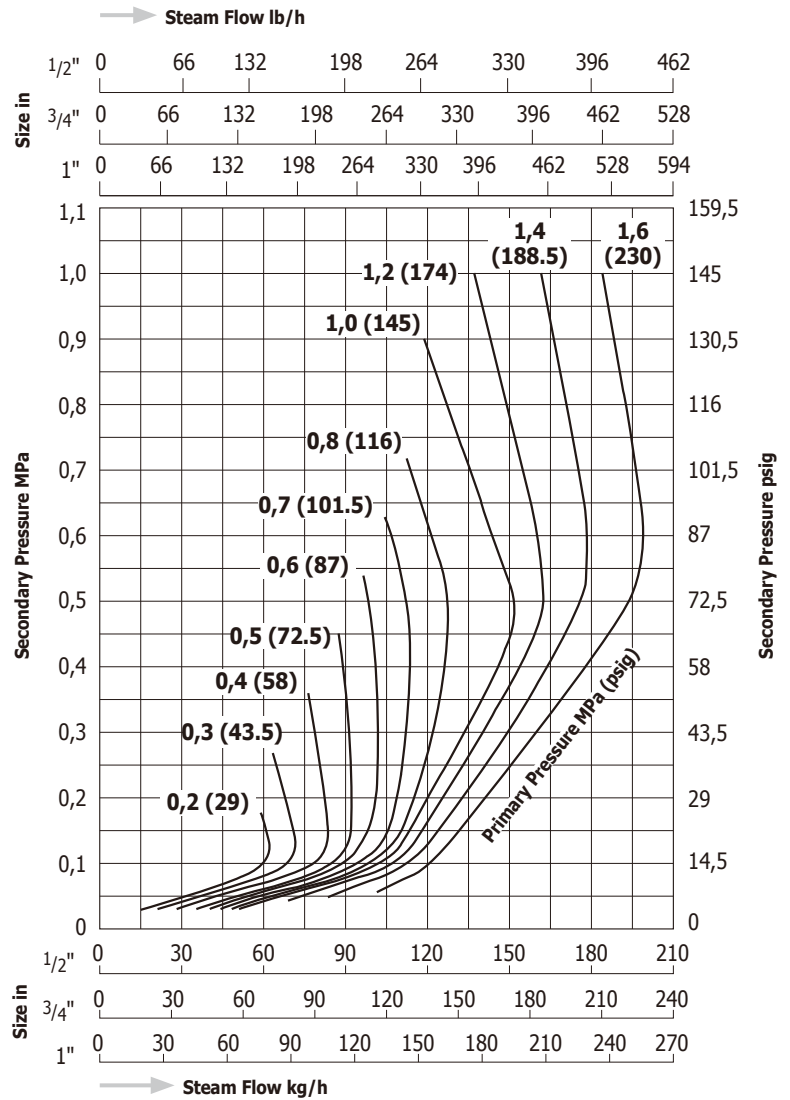
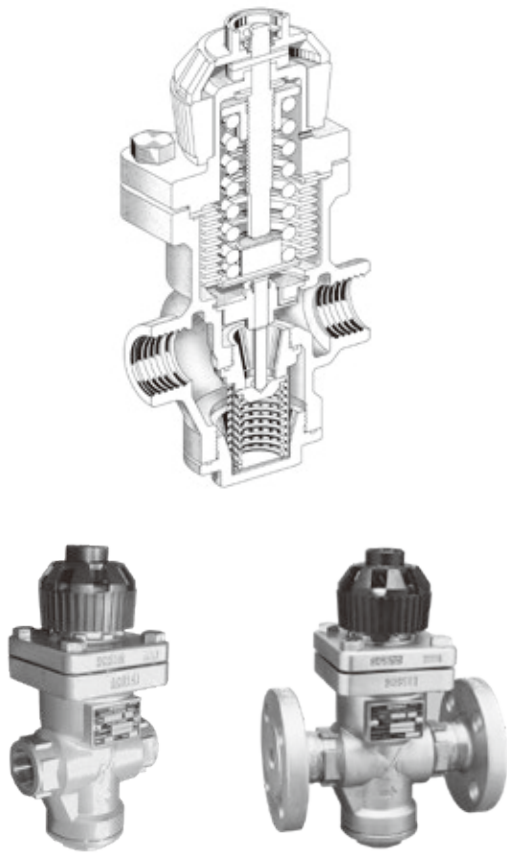

Minimum Differential Pressure:
more than 10 % of Operating Pressure

Body Material:
Stainless Steel SCS14

Dimensions REC1 - Screwed

Dimensions REC1 - Flanged

	Size (in)	REC1
Cv Values	1/2"	3,8
	3/4"	4,0
	1"	4,0
Kvs Values	1/2"	3,3
	3/4"	3,4
	1"	3,4

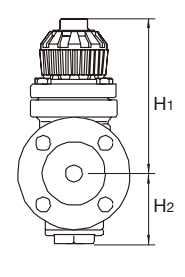
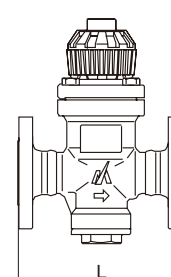
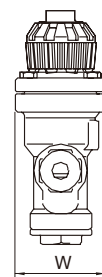
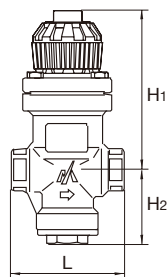

Model	Connections	Size (in)	Operating Pressure (Primary)		Secondary Pressure		Max. Red. Pressure Ratio	Max. Operating Temperature		Dimensions (mm)				Dimensions (in)				Weight											
			MPa	psig	MPa	psig		°C	°F	L	H ₁	H ₂	W	L	H ₁	H ₂	W	kg	lb										
REC1-2	Screwed Rc, NPT, Rp	1/2" - 1"	0,2 - 1,6	29 - 230	0,02 - 0,2	2,9 - 29	30 : 1	220	428	96	138	63	78	3,8	5,4	2,5	3,1	2,9	6,4										
REC1-6		1/2" - 1"	0,2 - 1,6	29 - 230	0,18 - 0,6	26 - 87	8,9 : 1											2,8	6,2										
REC1-10		1/2" - 1"	0,6 - 1,6	87 - 230	0,54 - 1,0	78 - 145	3 : 1											2,8	6,2										
REC1-2F	Flanged JIS, ASME, DIN	1/2"	0,2 - 1,6	29 - 230	0,02 - 0,2	2,9 - 29	30 : 1			220	428	150	138	63	78	5,9	5,4	2,5	3,1	4,5	9,9								
		3/4"																		5,1	11,2								
		1"																		5,9	13								
REC1-6F		Flanged JIS, ASME, DIN										1/2"	0,2 - 1,6	29 - 230	0,18 - 0,6	26 - 87	8,9 : 1	220	428	150	138	63	78	5,9	5,4	2,5	3,1	4,5	9,9
												3/4"																5,1	11,2
												1"																5,9	13
REC1-10F	Flanged JIS, ASME, DIN		1/2"	0,6 - 1,6	87 - 230	0,54 - 1,0	78 - 145			3 : 1	220	428								150	138	63	78	5,9	5,4	2,5	3,1	4,5	9,9
			3/4"																									5,1	11,2
			1"																									5,9	13

RE3

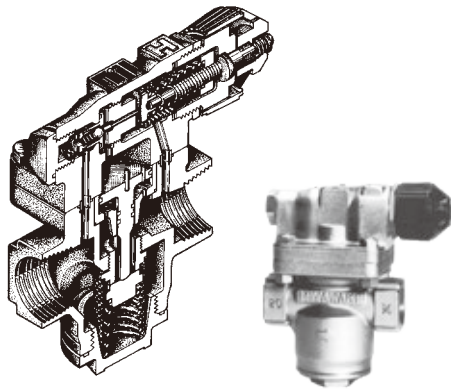

Body Material: Brass C3771

Dimensions RE3

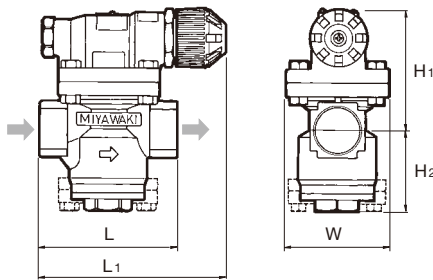

Minimum Differential Pressure:
0,07 MPa (10.2 psig)

Capacity Chart RE3

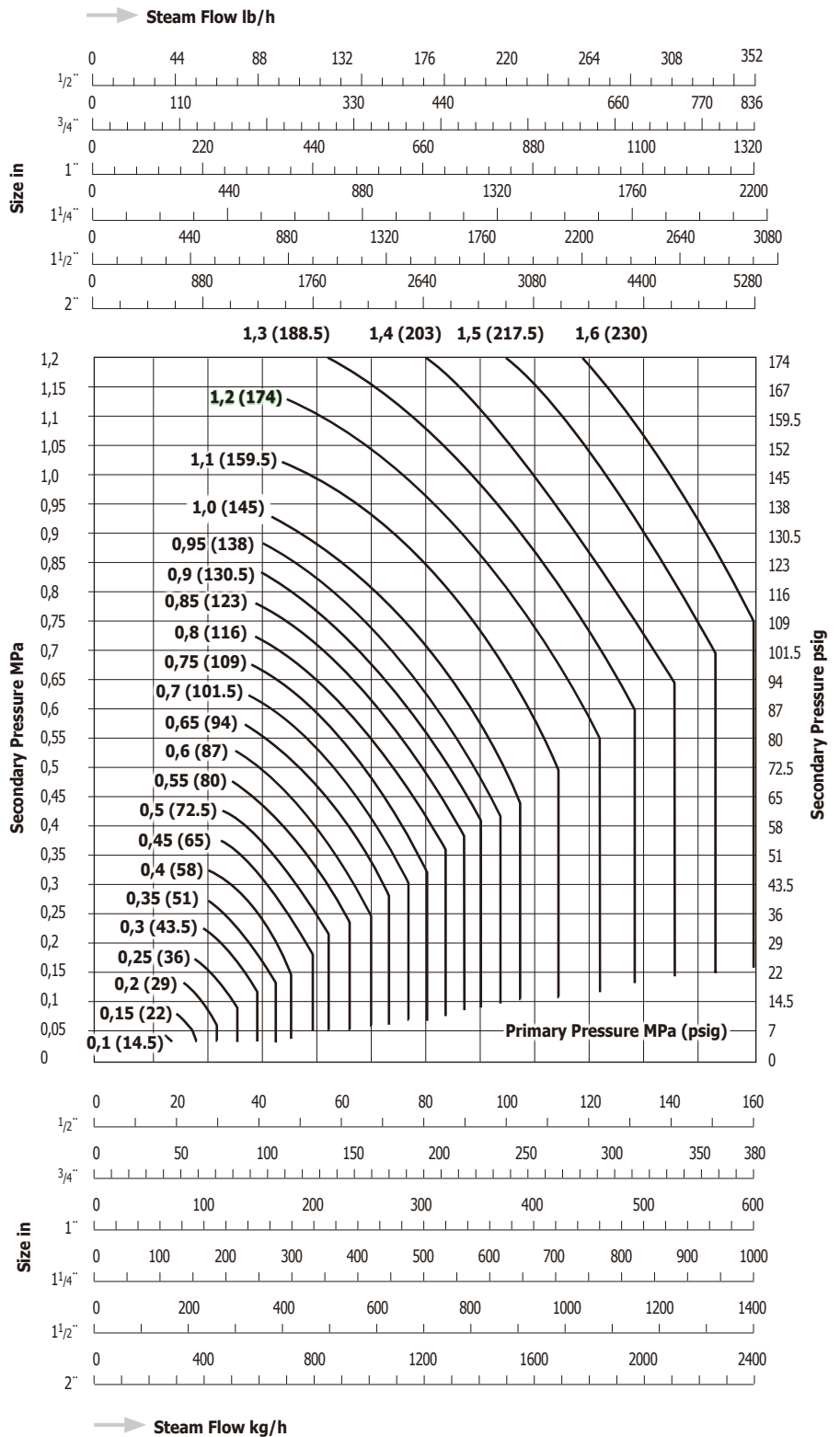

Model	Connection	Size (in)	Operating Pressure (Primary)		Secondary Pressure		Max. Red. Pressure Ratio	Max. Oper. Temperature		Dimensions (mm)					Dimensions (in)					Weight		Values	
			MPa	psig	MPa	psig		°C	°F	L	L ₁	H ₁	H ₂	W	L	L ₁	H ₁	H ₂	W	kg	lb	Cv	Kvs
RE3	Screwed Rc, NPT	1/2"	0,1 - 1,6	14.5 - 230	0,03 - 1,2	4.4 - 174	20 : 1	220	428	90	127	87	58	74	3.5	5.0	3.4	2.3	2.9	2,8	6,2	0,8	0,7
		95								130	3,7				5,1	2,9				6,4	1,9	1,6	
		100								132	3,9				5,2	3,0				2,6			
		1"								130	155	111	73	96	5.1	6.1	4.4	2.9	3.8	6,2	13,6	4,9	4,2
		1 1/4"								140	157	121	79	110	5.5	6.2	4.8	3.1	4.3	6,3	13,9	6,8	5,9
		1 1/2"								140	157	121	79	110	5.5	6.2	4.8	3.1	4.3	8,2	18,0	12,0	10,3
2"	140	157	121	79	110	5.5	6.2	4.8	3.1	4.3	8,2	18,0	12,0	10,3									

RE10N

Capacity Chart RE10N

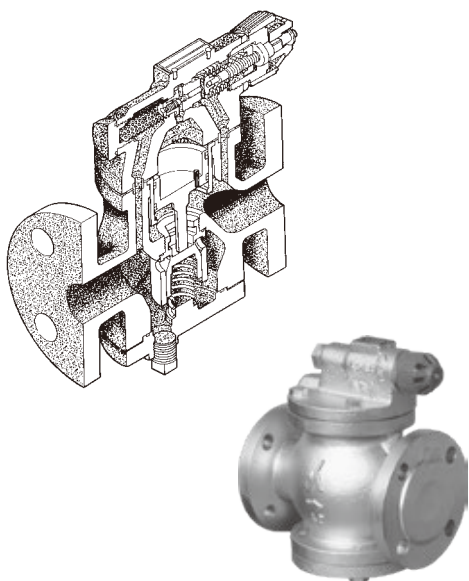

Body Material: Ductile Cast Iron FCD450

Dimensions RE10N

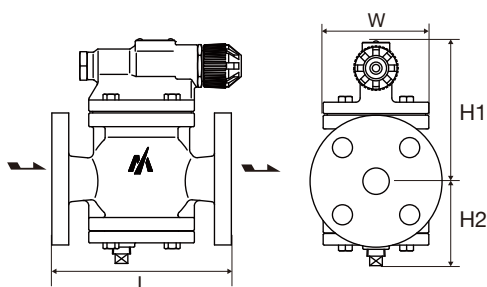

Minimum Differential Pressure:
0,07 MPa (10.2 psig)

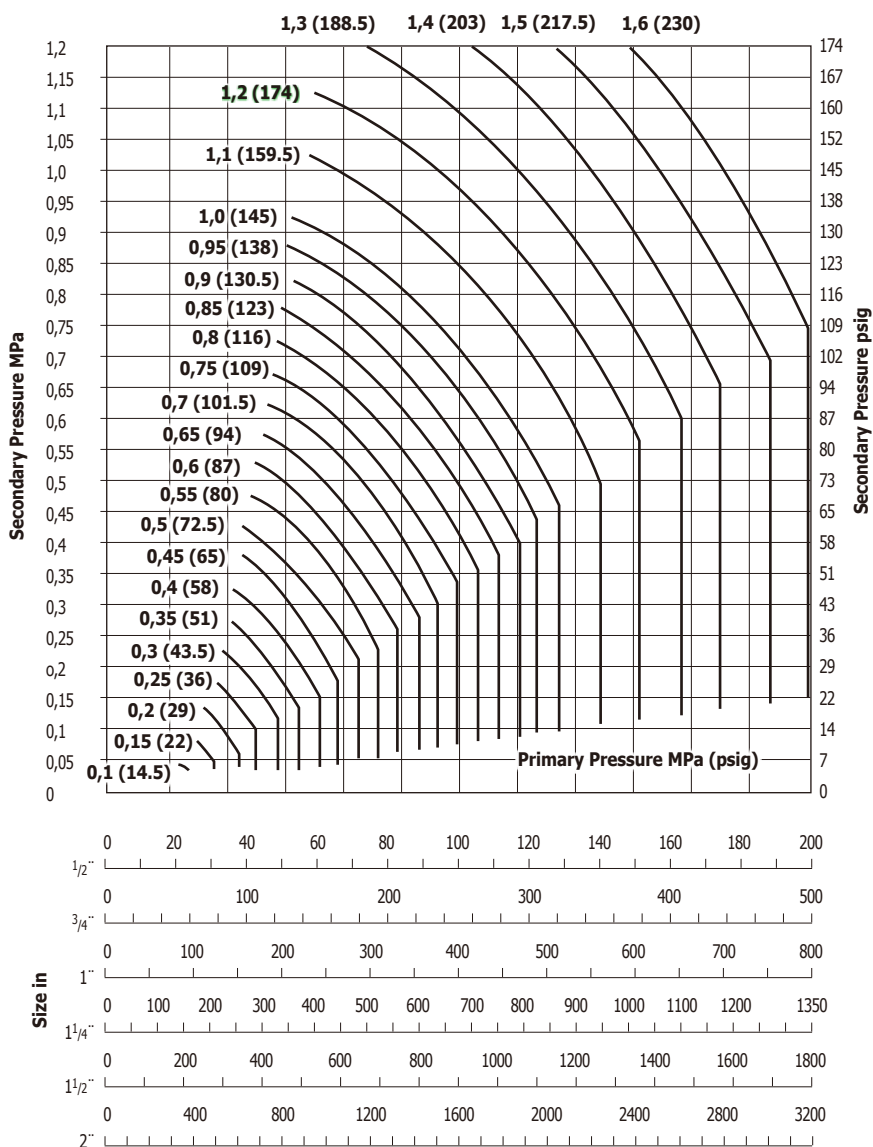
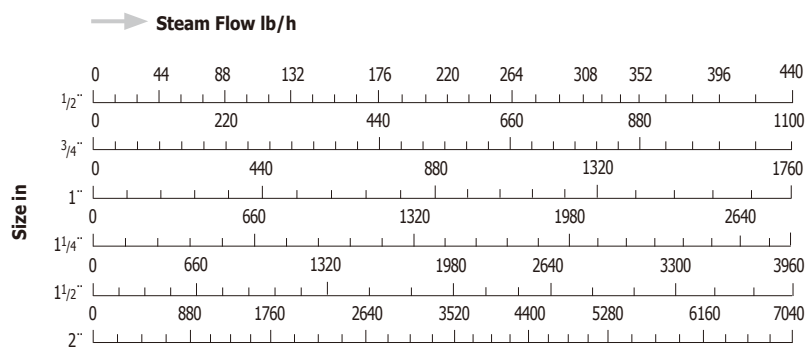

Model	Connection	Size (in)	Operating Pressure (Primary)		Secondary Pressure		Max. Red. Pressure Ratio	Max. Operating Temperature		Dimensions (mm)				Dimensions (in)				Weight		Values	
			MPa	psig	MPa	psig		°C	°F	L	H1	H2	W	L	H1	H2	W	kg	lb	Cv	Kvs
RE10N	Flanged JIS, ASME, DIN	1/2"	0,1 - 1,6	14.5 - 230	0,03 - 1,2	4.4 - 174	20 : 1	220	428	160	133	80	100	6.3	5.2	3.1	3.9	7,1	15,7	1,0	0,9
		3/4"								170				6.7				8,5	18,7	2,5	2,2
		1"								200				7.9	6.1	4.1	5.1	14,2	31,3	6,5	5,6
		1 1/4"								220	154	103	130	8.7				14,3	31,5	9,0	7,7
		2"																15,6	34,4	16,0	13,8

RE20 REH20 REC20

The model RE20 is a direct acting pressure reducing valve designed for use of steam. The valve provides a constant downstream pressure at a stable given inlet pressure and constant running flowrates. Changes in the upstream pressure and fluctuating steam consumption on the secondary side will result in variations in downstream pressure. The valve is not designed for dead-end services. Due to carefully selected springs a wide range of pressure applications is available. The pressure reducing valve can be delivered with ductile cast iron, cast steel or stainless steel housings. All important internal parts are manufactured in stainless steel. As option the valves can be equipped with a pressure gauge on the valve body. Maximum pressure reduction ratio: 25:1

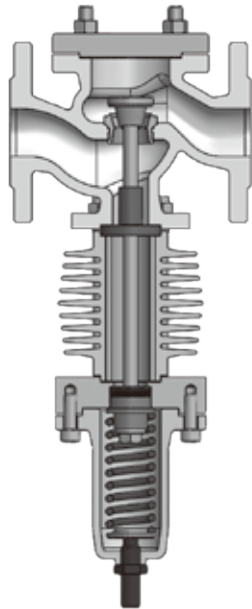

Size: DN 15 – 100

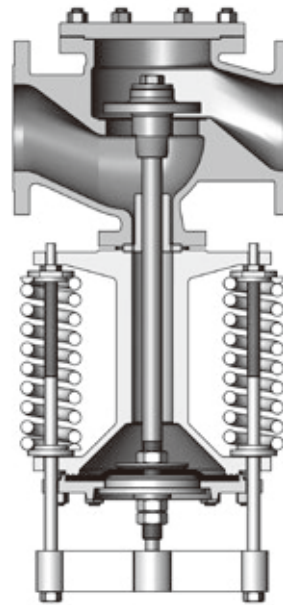

Size: DN 125 – 200

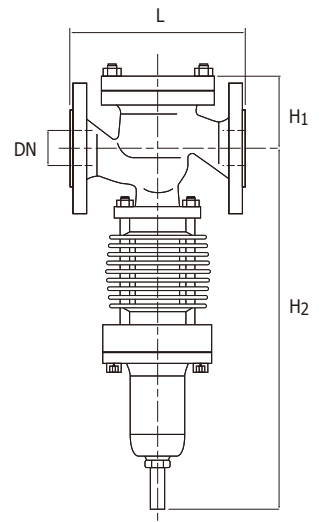

RE20L REH20L REC20L

The model RE20L is a pressure reducing valve with a downstream pressure sensing line (pulse line) designed for use of steam. The valve provides a precise downstream pressure even at changing inlet pressures. Due to carefully selected springs a wide range of pressure applications is available. The valve is very well suited to intermittent or fluctuating loads at the secondary side. It closes securely when the load on the secondary side will be zero. The pressure reducing valve can be delivered with ductile cast iron, cast steel or stainless steel housings. All important internal parts are manufactured in stainless steel. As option the valves can be equipped with a pressure gauge on the valve body. Maximum pressure reduction ratio: 25:1

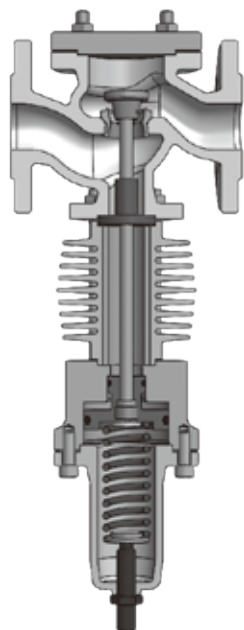
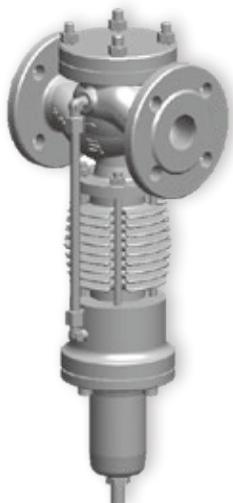

Size: DN 15 – 100

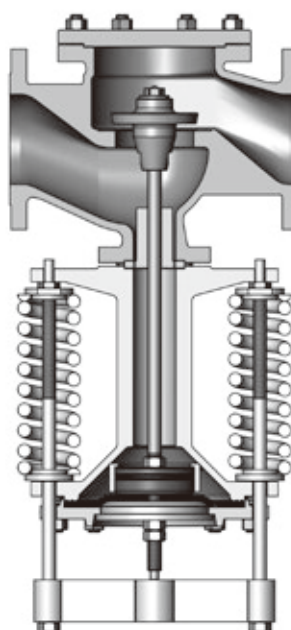

Size: DN 125 – 200

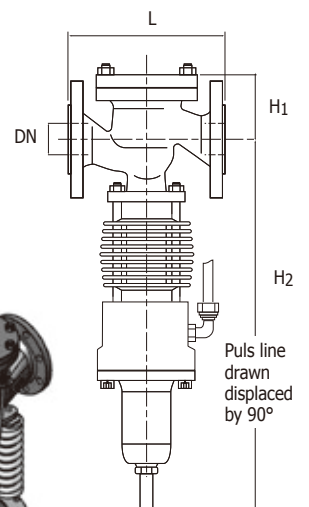

RE20 & RE20L

Body material

RE20 / RE20L	REH20 / REH20L	REH20-M / REH20L-M	REC20 / REC20L
PN16 & PN25	PN40, PN63 & PN100	PN63 & PN100	PN40
Ductile Cast Iron EN-GJS-400-15 (GGG-40, 0.7040)	Cast Steel GP240GH (GS-C25, 1.0619)	Cast Steel G17CrMo 5-5 (1.7357)	Stainless Steel GX5CrNiMo19-11-2 (1.4408)

Body design conditions

		RE20 / RE20L		REH20 / REH20L			REH20-M / REH20L-M		REC20 / REC20L
		PN16	PN25	PN40	PN63	PN100	PN63	PN100	PN40
Max. design pressure (MPa)	PMA	1,6	2,5	4,0	6,3	10,0	6,3	10,0	4,0
Max. design temperature (°C)	TMA	350	350	400	400	400	530	530	400
Max. operating pressure (MPa)	PMO	1,5	2,2	2,8	4,0	6,4	5,7	8,4	2,9
Max. operating temperature (°C)	TMO	350	350	400	400	400	530	530	400

Pressure – Temperature rating

PN	Body material	Temperature °C										
		-10... +50	100	150	200	250	300	350	400	450	500	530
		Pressure MPa										
16	0.7040	1,6	1,6	1,6	1,5	1,4	1,3	1,1				
25	0.7040	2,5	2,5	2,4	2,3	2,2	2,0	1,8				
40	1.0619	4,0	3,7	3,5	3,1	2,8	2,6	2,4	2,3			
	1.4408	4,0	3,7	3,4	3,1	2,9	2,8	2,7	2,6			
63	1.0619	6,3	5,9	5,5	4,9	4,5	4,1	3,8	3,6			
	1.7357	6,3	6,3	6,3	6,3	6,2	5,7	5,3	5,0	4,8	3,8	2,2
100	1.0619	10,0	9,3	8,7	7,8	7,1	6,4	6,0	5,8			
	1.7357	10,0	10,0	10,0	10,0	9,8	9,1	8,4	8,0	7,6	6,1	3,5

Available secondary pressure ranges

Downstream pressure range	RE20 REH20 REC20	RE20L REH20L REC20L
	MPa	
< 0,05	n/a	on request
0,05 – 0,1	n/a	✓
0,1 – 0,16	✓	✓
0,16 – 0,25	✓	✓
0,25 – 0,4	✓	✓
0,4 – 0,63	✓	✓
0,63 – 1,0	✓	✓
1,0 – 1,6	✓	on request
> 1,6	on request	on request

Minimum differential pressure:
0,05 MPa (DN15-50), 0,07 MPa (DN65-125), 0,1 MPa (DN150-200)

Dimensions & Weights

Size (DN)	Model RE20 (REH20, REC20)							Model RE20L (REH20L, REC20L)						Kvs Value	
	Dimensions (mm)				Weight (kg)			Dimensions (mm)				Weight (kg)			
	L		H1	H2	0.7040	1.0619	1.4408	L		H1	H2	0.7040	1.0619		1.4408
	PN16-40	PN63-100						PN16-40	PN63-100						
15	130	210	82	410	11,4	12,0	12,0	130	210	82	435	13,0	14,5	14,5	8,0
20	150	230	66		11,4	12,0	12,0	150	230	66		13,0	14,5	14,5	11,0
25	160	230	66		12,5	13,0	13,0	160	230	66		14,5	16,5	16,5	12,0
32	180	260	81		14,5	16,0	16,0	180	260	81		16,0	18,5	18,5	12,0
40	200	260	83		16,0	18,0	18,0	200	260	83		18,0	22,0	22,0	14,0
50	230	300	100	586	35,0	37,5	37,5	230	300	100	647	34,0	37,5	37,5	63,0
65	290	340	113	615	39,5	43,0	43,0	290	340	113	690	45,0	49,0	49,0	92,0
80	310	380	140	733	52,5	58,0	58,0	310	380	140	828	61,0	65,0	65,0	113,0
100	350	430	154	762	68,0	77,0	77,0	350	430	154	850	87,0	91,0	91,0	150,0
125	400		210	715	150,0	155,0	155,0	400		210	715	150,0	155,0	155,0	196,0
150	480		235	720	180,0	190,0	190,0	480		235	720	180,0	190,0	190,0	321,0
200	600		285	950	330,0	385,0	385,0	600		285	950	330,0	385,0	385,0	483,0

Connections: Flanged EN-DIN1092, ASME B16.5

For leakage class 6 acc. to ANSI order with soft sealing

For more information see the special MIYAWAKI leaflet.

REA20 REAH20 REAC20

The model REA20 is a direct acting pressure reducing valve designed for use of compressible media, such as air and various gases and for incompressible media such as water, oil and others. The valve provides a constant downstream pressure at a stable given inlet pressure and constant running flowrates. Changes in the upstream pressure and fluctuating consumption on the secondary side will result in variations in downstream pressure. The valve is not designed for dead-end services. Due to carefully selected springs a wide range of pressure applications is available. The pressure reducing valve can be delivered with ductile cast iron, cast steel or stainless steel housings. All important internal parts are manufactured in stainless steel. Depending on the medium the valve can be equipped with soft sealing or metal sealing valves/seats. As option the valves can be equipped with a pressure gauge on the valve body. Maximum pressure reduction ratio: 25:1

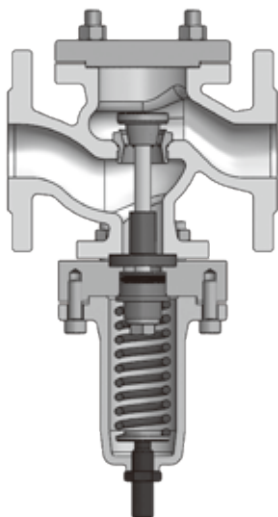

Size: DN 15 – 100

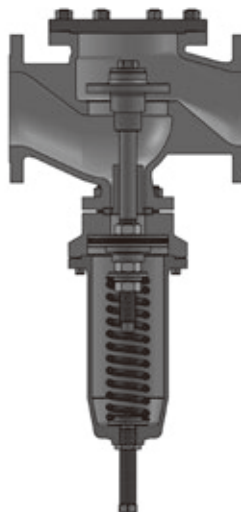

Size: DN 125 – 200

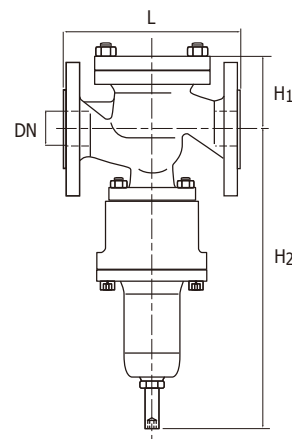

REA20L REAH20L REAC20L

The model REA20L is a pressure reducing valve designed for use of compressible media, such as air and various gases and for incompressible media such as water, oil and others. Due to the use of a downstream pressure sensing line (pulse line) the valve provides a constant accurate downstream pressure. Carefully selected springs secure a wide range of downstream pressure applications. The pressure reducing valve can be delivered with ductile cast iron, cast steel or stainless steel housings. All important internal parts are manufactured in stainless steel. The valve is designed for dead-end services. In case of zero consumption on the secondary side the valve closes reliably. Depending on the medium the valve can be equipped with soft sealing or metal sealing valves/seats. As option the valves can be equipped with pressure gauges. Maximum pressure reduction ratio: 25:1

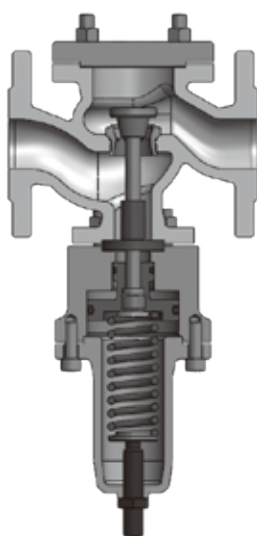
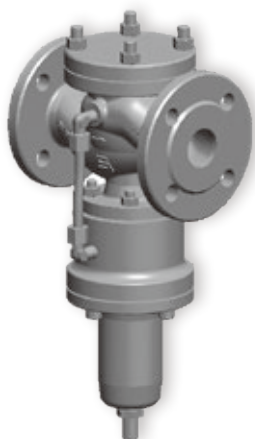

Size: DN 15 – 100

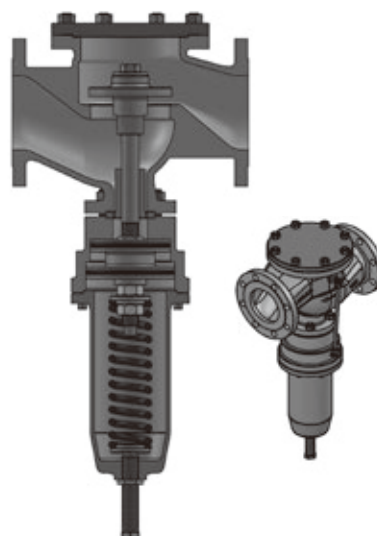

Size: DN 125 – 200

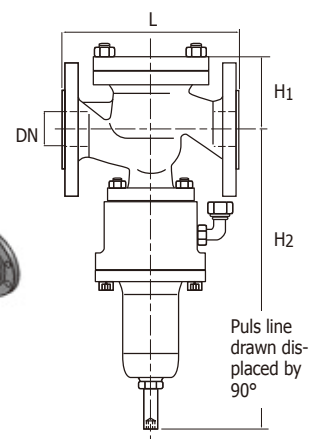

- Usable for the following gases :

Acetylene, Ammonia, Argon, Carbon dioxide, Carbon monoxide, Chlorine, Coal gas, Hydrogen, Ethylene, Helium, Methane, Nitrogen, Oxygen*, Sulphur dioxide

Others may be possible as well. Please ask MIYAWAKI Inc. or an authorized representative for more detail.

- Special cleaning to make the product oil-free / grease-free is available at an additional cost.

*** Special cleaning is mandatory for oxygen applications.**

REA20 & REA20L

Body material

REA20 / REA20L	REAH20 / REAH20L	REAH20-M / REAH20L-M	REAC20 / REAC20L
PN16 & PN25	PN40, PN63 & PN100	PN63 & PN100	PN40
Ductile Cast Iron EN-GJS-400-15 (GGG-40, 0.7040)	Cast Steel GP240GH (GS-C25, 1.0619)	Cast Steel G17CrMo 5-5 (1.7357)	Stainless Steel GX5CrNiMo19-11-2 (1.4408)

Body design conditions

		REA20 / REA20L		REAH20 / REAH20L			REAH20-M / REAH20L-M		REAC20 / REAC20L
		PN16	PN25	PN40	PN63	PN100	PN63	PN100	PN40
Max. design pressure (MPa)	PMA	1,6	2,5	4,0	6,3	10,0	6,3	10,0	4,0
Max. design temperature (°C)	TMA	350	350	400	400	400	530	530	400
Max. operating pressure (MPa)	PMO	1,6	2,5	4,0	6,3	10,0	6,3	10,0	4,0

The max. operating temperature (°C) TMO depends for all on the O-Ring material: 120 °C with NBR, 130 °C with EPDM, 200 °C with FKM.

Pressure – Temperature rating

PN	Body material	Temperature °C										
		-10... +50	100	150	200	250	300	350	400	450	500	530
		Pressure MPa										
16	0.7040	1,6	1,6	1,6	1,5	1,4	1,3	1,1				
25	0.7040	2,5	2,5	2,4	2,3	2,2	2,0	1,8				
40	1.0619	4,0	3,7	3,5	3,1	2,8	2,6	2,4	2,3			
	1.4408	4,0	3,7	3,4	3,1	2,9	2,8	2,7	2,6			
63	1.0619	6,3	5,9	5,5	4,9	4,5	4,1	3,8	3,6			
	1.7357	6,3	6,3	6,3	6,3	6,2	5,7	5,3	5,0	4,8	3,8	2,2
100	1.0619	10,0	9,3	8,7	7,8	7,1	6,4	6,0	5,8			
	1.7357	10,0	10,0	10,0	10,0	9,8	9,1	8,4	8,0	7,6	6,1	3,5

Available secondary pressure ranges

Downstream pressure range	MPa	REA20 REAH20 REAC20	REA20L REAH20L REAC20L
		< 0,05	n/a
0,05 – 0,1		n/a	✓
0,1 – 0,16		✓	✓
0,16 – 0,25		✓	✓
0,25 – 0,4		✓	✓
0,4 – 0,63		✓	✓
0,63 – 1,0		✓	✓
1,0 – 1,6		✓	on request
> 1,6		on request	on request

Minimum differential pressure:
0,05 MPa (DN15-50), 0,07 MPa (DN65-125), 0,1 MPa (DN150-200)

Dimensions & Weights

Size (DN)	Model REA20 (REAH20, REAC20)							Model REA20L (REAH20L, REAC20L)							Kvs Value
	Dimensions (mm)				Weight (kg)			Dimensions (mm)				Weight (kg)			
	L		H1	H2	0.7040	1.0619	1.4408	L		H1	H2	0.7040	1.0619	1.4408	
	PN16-40	PN63-100						PN16-40	PN63-100						
15	130	210	82	289	13,0	14,5	14,5	130	210	82	315	13,0	14,5	14,5	8,0
20	150	230	66		13,0	14,5	14,5	150	230	66		13,0	14,5	14,5	11,0
25	160	230	66		14,5	16,5	16,5	160	230	66		14,5	16,5	16,5	12,0
32	180	260	81		16,0	18,5	18,5	180	260	81		16,0	18,5	18,5	12,0
40	200	260	83		18,0	22,0	22,0	200	260	83		18,0	22,0	22,0	14,0
50	230	300	100	416	34,0	37,5	37,5	230	300	100	477	34,0	37,5	37,5	63,0
65	290	340	113	445	45,0	49,0	49,0	290	340	113	520	45,0	49,0	49,0	92,0
80	310	380	140	553	61,0	65,0	65,0	310	380	140	648	61,0	65,0	65,0	113,0
100	350	430	154	582	87,0	91,0	91,0	350	430	154	670	87,0	91,0	91,0	150,0
125	400		210	715	120,0	120,0	120,0	400		210	660	125,0	125,0	125,0	196,0
150	480		235	720	130,0	135,0	135,0	480		235	680	150,0	160,0	160,0	321,0
200	600		285	950	230,0	280,0	280,0	600		285	740	245,0	300,0	300,0	483,0

Connections: Flanged EN-DIN1092, ASME B16.5

For leakage class 6 acc. to ANSI order with soft sealing

For more information see the special MIYAWAKI leaflet.

RE1

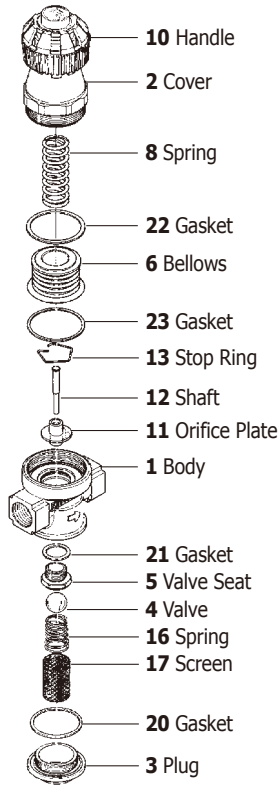

REC1

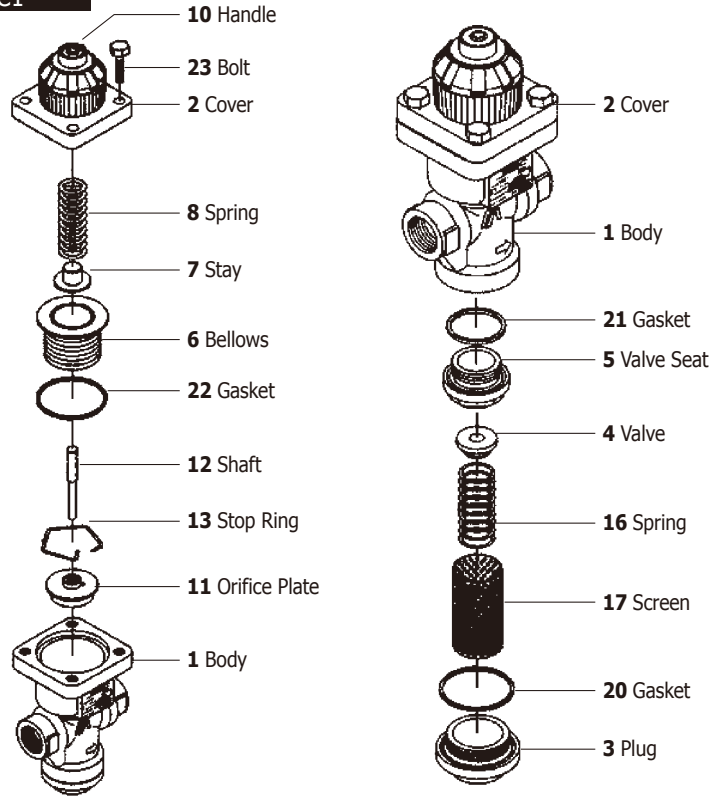

RE3

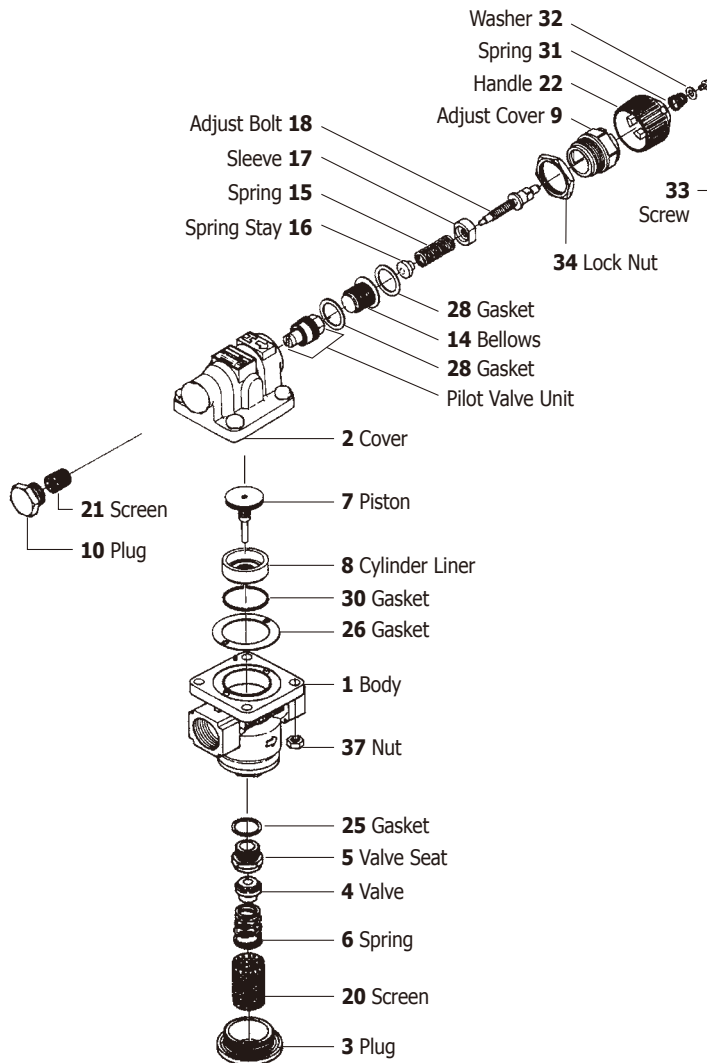

RE10N

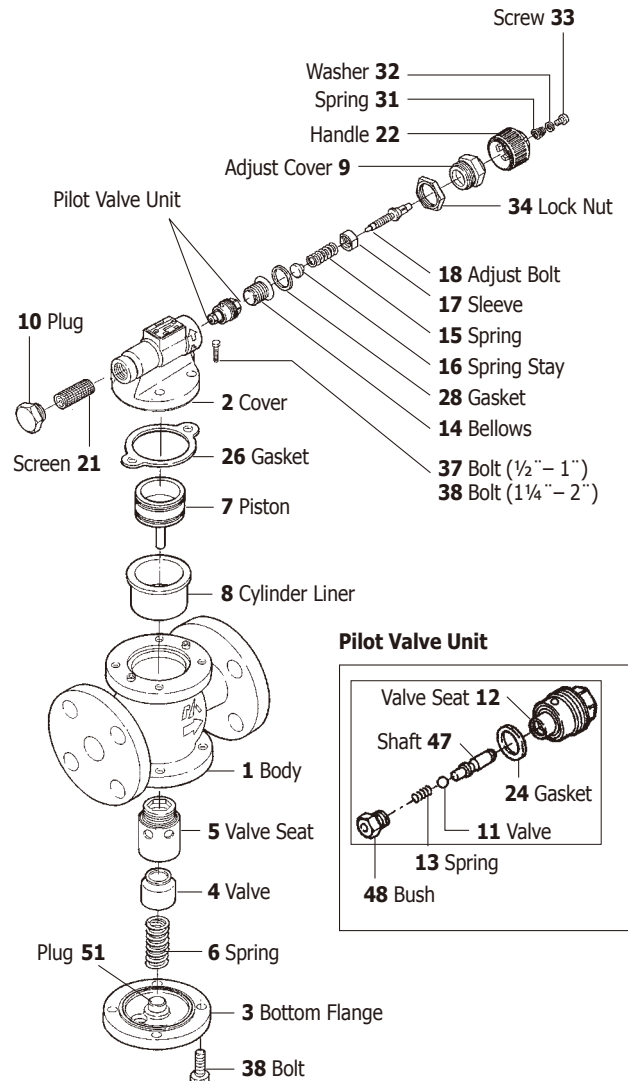

Steam-Water-Mixing Valve

SERIES MX

MX1N

Features

1. Temperature is thermostatically controlled.
2. Can be installed where steam and cold water are available.
3. Produces hot water quickly and efficiently.
4. Efficient energy saving.
5. Precise thermostatic control.
6. Inline repairability.
7. Nickel plated finish.

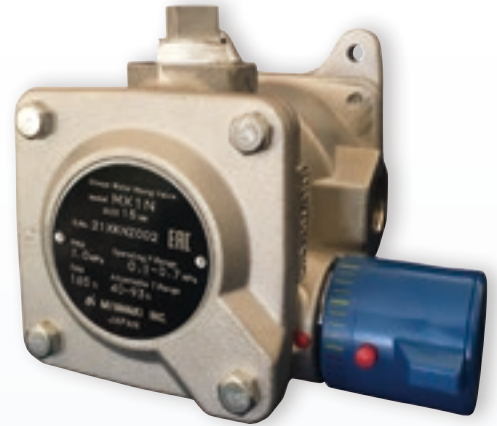

Suitable for

Washing down floors, vehicles, vats, jacketed vessels, backflushing filters, washing out vessels and other equipment in the dairy, brewery, food, chemical and soap manufacturing industries and wherever hot water is required economically.

Operating principle

●●● Cold water
 ■ Hot water
 ■ Steam

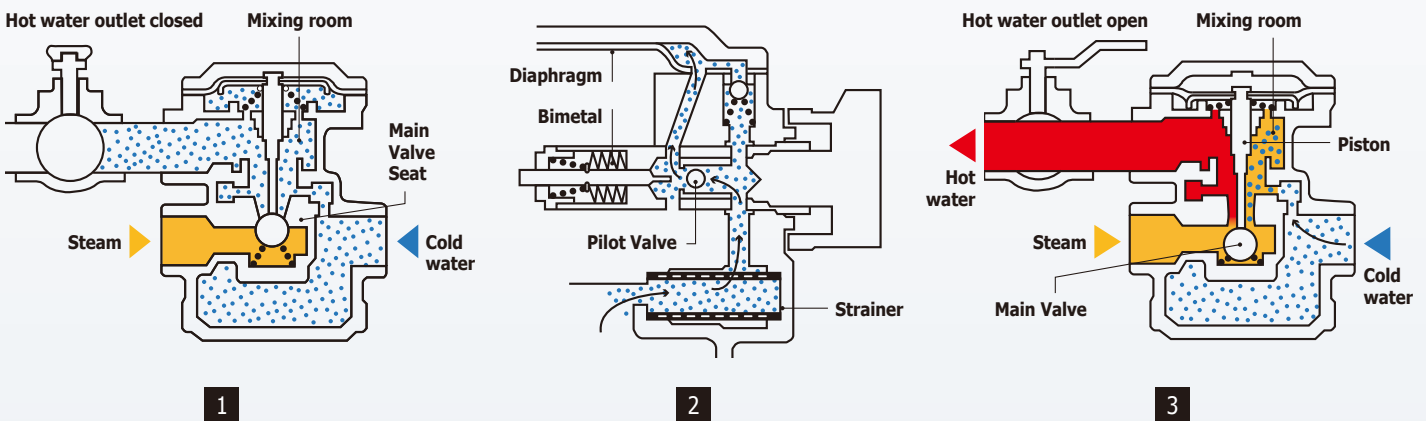

The cold water occupies the lower part of the body completely, flows through a hole next to the seat of the main valve into the mixing room and occupies it up to the hot water outlet. The main valve is closed. The steam can't enter the mixing room.

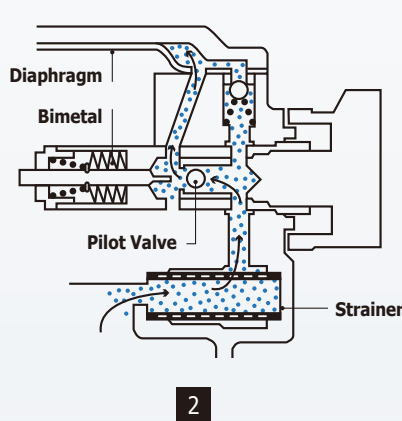

When you open the hot water outlet the cold water flows from the mixing room to the hot water outlet. During this process one part of the cold water flows through the strainer and runs behind the pilot valve (which is connected with the bimetal unit) into the space above the diaphragm.

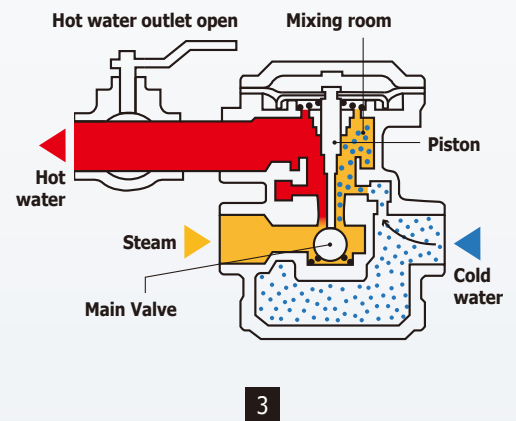

The water pressure in the space above the diaphragm increases and pushes the diaphragm and the connected piston downwards. Consequently, the main valve opens and the steam flows into the mixing room and mixes with the cold water. The hot water flows to the hot water outlet.

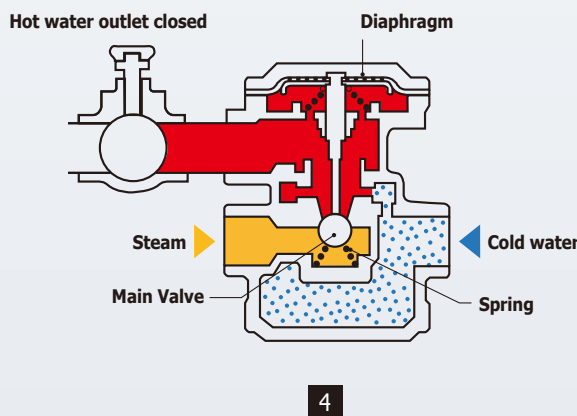

When the hot water outlet is being closed the pressure in the mixing room rises, the pressure on the diaphragm increases and the diaphragm returns to its original position. The main valve closes due to the pressure of the spring and the steam.

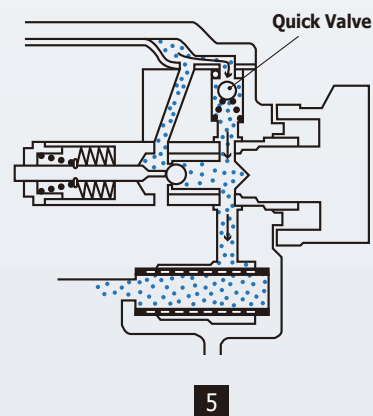

The pressure above the diaphragm is equalized by the quick valve. The pilot valve is closed.

MX1N Steam-Water-Mixing Valve

Dimensions

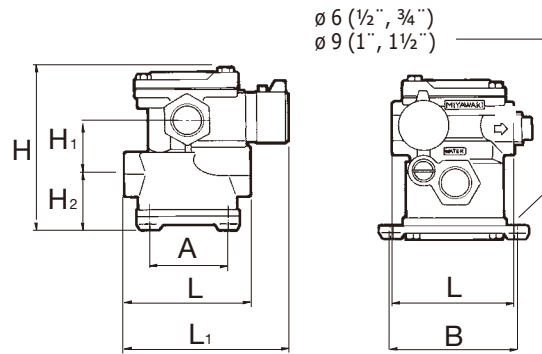
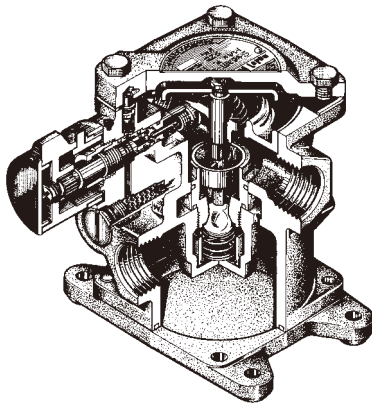

Connection	Size	Max. Flow Pressure				Min. Flow Pressure				Max. Temperature		Max. Pressure Ratio steam : water (water : steam)	Max. Temperature		Dimensions mm (in)								Weight	
		Steam		Water		Steam		Water		Steam			Hot Water	°C	°F	L	L ₁	H	H ₁	H ₂	A	B	kg	lb
		MPa	psig	MPa	psig	MPa	psig	MPa	psig	°C	°F													
Screwed Rc, NPT	1/2"	0,7	101.5	0,7	101.5	0,1	14.5	0,1	14.5	185	365	3 : 1 *	93	199	100	138	134	43	47	62	102	3,9	8.6	
	(3.9)														(5.4)	(5.3)	(1.7)	(1.9)	(2.4)	(4.0)				
	140														179	168	57	51	86	147	8,6			19.0
(5.5)	(7.0)	(6.6)	(2.2)	(2.0)	(3.4)	(5.8)																		
1/2"	0,5	72.5	0,5	72.5								*Recommended 1 : 1			160	189	197	70	60	86	147	14,1	31.1	
															(6.3)	(7.4)	(7.8)	(2.8)	(2.4)	(3.4)	(5.8)			

Body Material: Brass C3771 (JIS); PMA = 1,0 MPa (145 psig), TMA = 185°C (365°F)

Hot Water Capacity MX1N

Ratio Steam Pressure : Cold Water Pressure = 1 : 1, Cold Water Temperature 15°C

Size (in)	Pressure		Hot Water Flow Amount (l/min)											
			40°C		50°C		60°C		70°C		80°C		90°C	
	MPa	psig	Min.	Max.	Min.	Max.	Min.	Max.	Min.	Max.	Min.	Max.	Min.	Max.
1/2"	0,1	14.5	3	12	3	12	3	13	5	13	5	11	5	10
	0,2	29.0	3	20	3	21	3	21	5	20	5	17	10	14
	0,3	43.5	6	25	6	25	6	26	9	26	9	22	13	19
	0,4	58.0	6	29	6	29	6	29	12	30	12	28	17	24
	0,5	72.5	7	32	7	32	8	33	13	34	18	34	29	29
	0,6	87.0	7	35	7	36	16	36	17	37	27	37	34	34
	0,7	101.5	8	38	9	38	21	39	21	40	37	40	38	38
3/4"	0,1	14.5	5	22	5	23	5	20	8	17	8	14	9	12
	0,2	29.0	5	32	5	32	5	31	8	25	8	21	13	18
	0,3	43.5	8	39	8	39	8	40	10	34	10	28	25	25
	0,4	58.0	9	45	9	45	9	46	14	42	20	36	31	31
	0,5	72.5	11	50	11	51	11	52	15	51	23	43	37	37
	0,6	87.0	12	55	12	55	23	56	23	57	42	50	43	43
	0,7	101.5	14	59	15	60	44	61	45	62	56	56	49	49
1"	0,1	14.5	30	54	30	54	29	47	23	38	20	32	17	28
	0,2	29.0	38	76	39	77	48	70	37	57	31	49	27	42
	0,3	43.5	48	93	48	94	65	94	52	77	44	65	38	56
	0,4	58.0	54	107	55	109	66	111	67	97	57	82	49	71
	0,5	72.5	60	120	66	122	67	124	82	116	69	98	60	85
	0,6	87.0	66	131	67	133	68	135	97	136	82	115	71	100
	0,7	101.5	71	142	72	144	73	146	107	149	93	130	81	112
1 1/2"	0,1	14.5	91	140	83	116	64	90	53	74	45	63	39	54
	0,2	29.0	116	197	137	175	100	136	82	112	69	94	60	82
	0,3	43.5	136	242	170	235	136	183	112	149	94	126	82	110
	0,4	58.0	153	279	170	284	172	229	141	188	119	159	103	138
	0,5	72.5	171	312	173	317	210	276	172	226	146	191	126	166

Max. Temperature of hot water – Ratio Steam Pressure 1 : 1

1/2"	93°C	3/4"	93°C	1"	93°C	1 1/2"	93°C
------	------	------	------	----	------	--------	------

For hot water capacity when using ratio besides 1 : 1, please contact MIYAWAKI Inc. or an authorized representative.

MX1N Installation Examples

Spare Parts MX1N

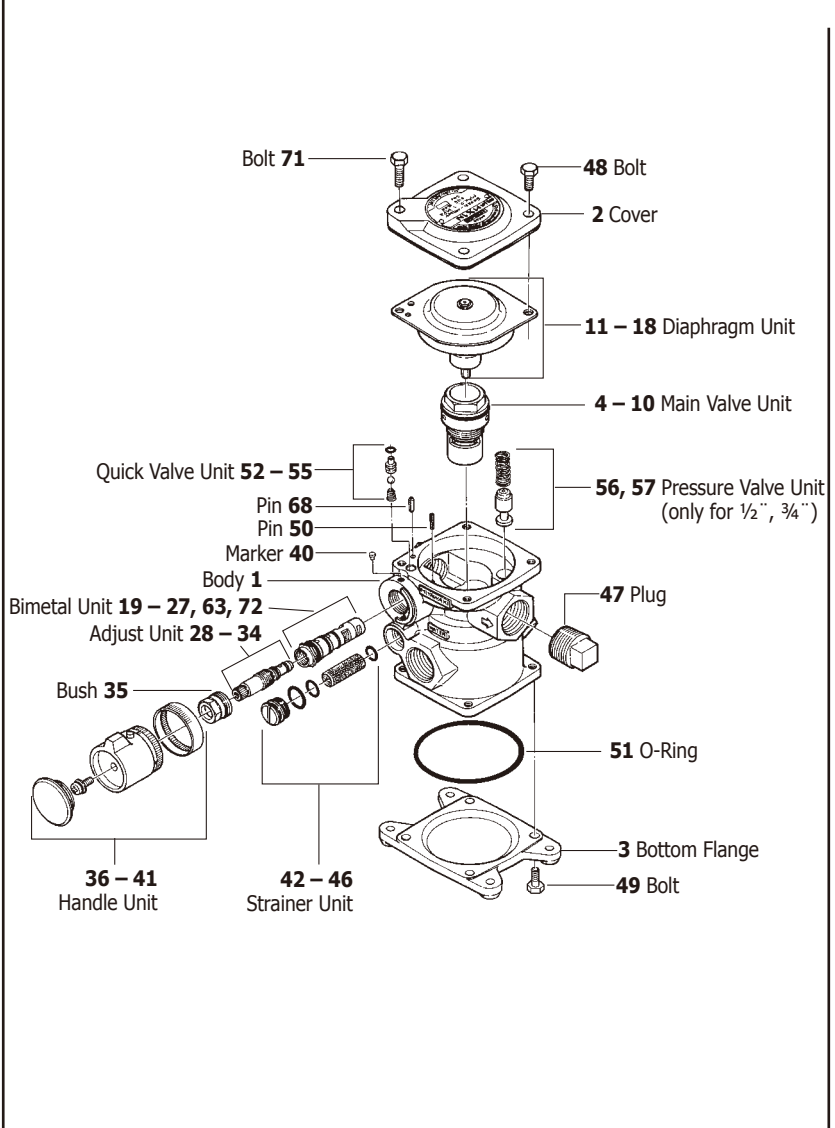
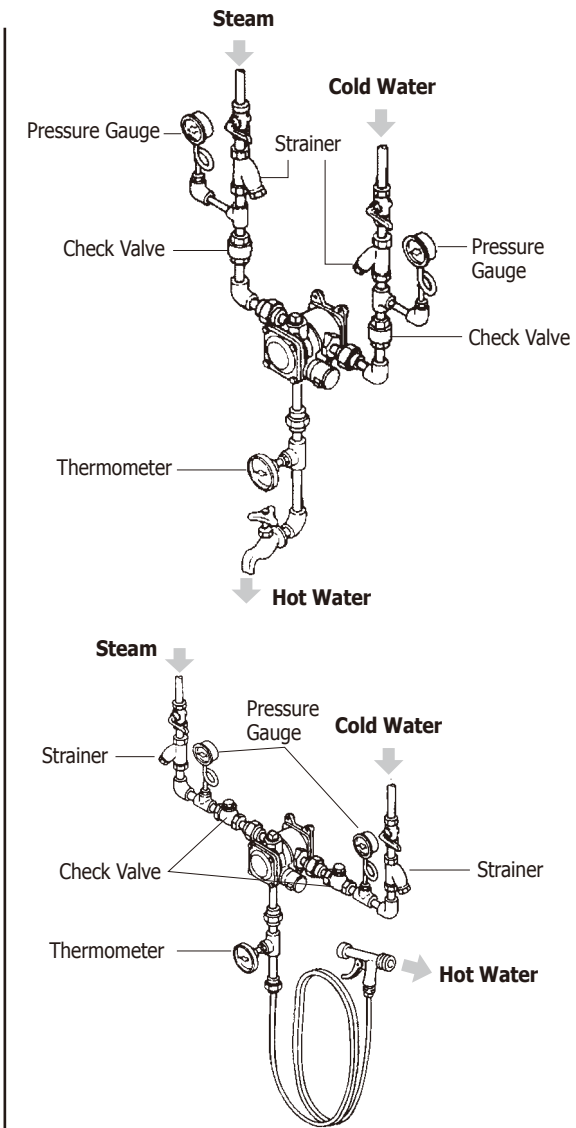

Water Gun MK

MK

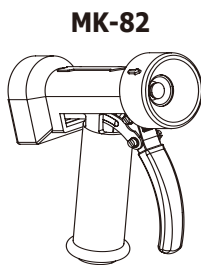
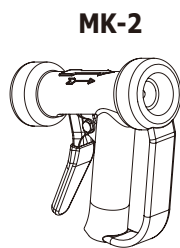

Features

1. Trigger operated water gun. Front trigger or rear trigger available
2. Perfect water consumption control
3. One-handed mode with either variable spray or direct jet
4. Automatic and immediate shut-off when the trigger is released

Suitable for

- MK2** is suitable for most industrial applications
- MK-MV** is recommended for use with Steam-Water-Mixing Valves

Model	Material	Rubber Cover	Trigger	Orifice Size		Max. Pressure	
				in	mm	MPa	psi
MK-2	Gunmetal or Stainless Steel	Black or White	rear	5/16"	7,9	0,7	101.5
MK-OH				7/16"	11,1		
MK-MV				9/16"	14,3		
MK-78	Gunmetal	Black or White	front	5/16"	7,9	1,4	203.0
MK-80				7/16"	11,1		
MK-82				9/16"	14,3		

Pressure		Orifice Size			Orifice Size		
		5/16"	7/16"	9/16"	5/16"	7/16"	9/16"
MPa	psig	l/min			GPM		
0,035	5.0	3,2	13,5	15,0	0.84	3.56	3.96
0,07	10.2	5,6	20,0	21,0	1.48	5.28	5.54
0,1	14.5	7,0	22,5	24,0	1.85	5.94	6.34
0,2	29.0	10,0	25,0	36,0	2.64	6.60	9.50
0,3	43.5	12,5	32,0	47,0	3.30	8.45	12.41
0,35	50.8	14,5	37,0	52,0	3.83	9.77	13.73
0,4	58.0	16,0	38,0	55,0	4.22	10.03	14.52
0,5	72.5	18,0	40,0	60,0	4.75	10.56	15.84
0,6	87.0	20,5	42,0	65,0	5.41	11.09	17.16
0,7	101.5	22,3	44,0	69,0	5.89	11.62	18.22
1,0	145.0	27,5	51,0	-	7.26	13.46	-
1,5	217.5	35,0	62,0	-	9.24	16.37	-
2,0	290.0	43,0	74,0	-	11.35	19.54	-
2,5	362.5	50,5	85,0	-	13.33	22.44	-

CVC3, CVC3R, CV5R



Pressure Drop Chart

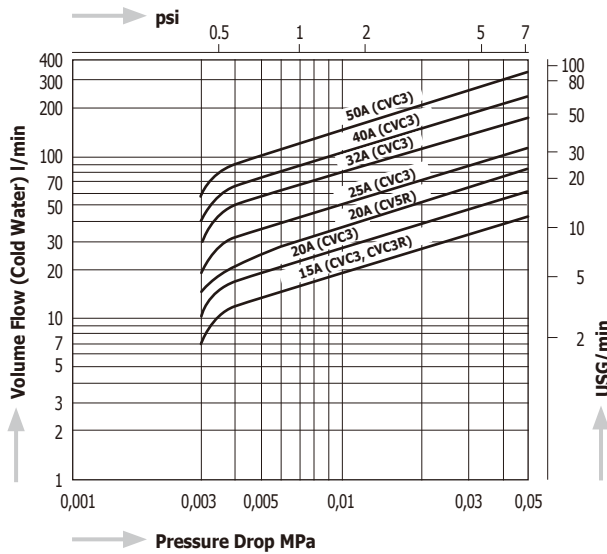

Dimensions

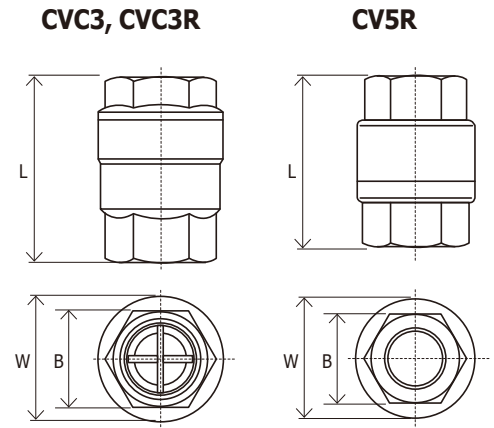

Model	Connections	Size	Max. Operating Pressure		Opening Pressure		Max. Operating Temperature		Dimensions (mm)			Dimensions (in)			Body Material	Weight	
			MPa	psig	MPa	psig	°C	°F	L	W	B	L	W	B		kg	lb
CVC3	Screwed Rc, NPT	1/2"	2,1	305	0,003	0,44	220	428	48	35	27	1.9	1.4	1.1	Stainless Steel SCS13A	0,2	0,4
		3/4"							61	43	33	2.4	1.7	1.3		0,3	0,7
		1"							73	54	41	2.9	2.1	1.6		0,6	1,3
		1 1/4"							80,5	62	50	3.2	2.4	2.0		0,8	1,8
		1 1/2"							87	75	58	3.4	3.0	2.3		1,2	2,6
		2"							100	90	72	3.9	3.5	2.8		1,8	4,0
CVC3R	Screwed Rc, NPT	1/2"	2,1	305	0,003	0,44	80	176	48	35	27	1.9	1.4	1.1	SCS13A	0,2	0,4
CV5R	Screwed Rc, NPT	3/4"	1,6	230	0,003	0,44	80	176	60	46	34	2.4	1.8	1.3	SCS13A	0,29	0,6

VB1, VB1R Blow-down Valve

VB1, VB1R

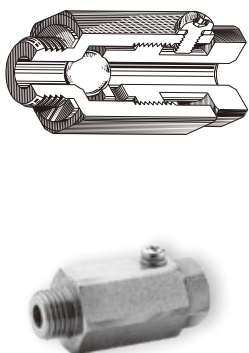

Capacity Chart

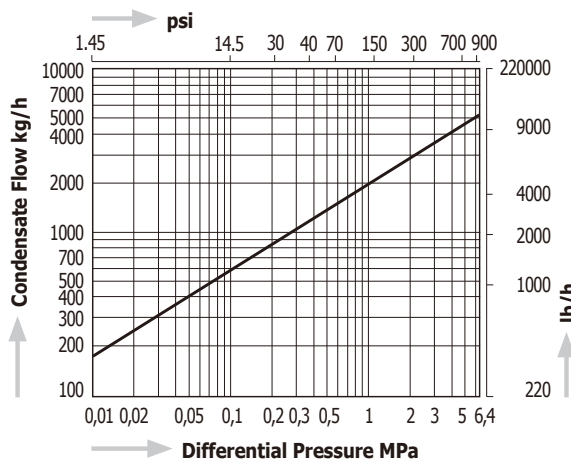

Dimensions

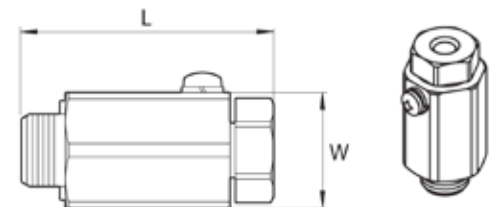

Model	Connection	Size	Max. Operating Pressure		Max. Operating Temperature		Dimensions (mm)				Dimensions (in)				Body Material	Weight	
			MPa	psig	°C	°F	L	H1	H2	W	L	H1	H2	W		kg	lb
VB1	Screwed G	1/4"	6,4	928	425	800	46			25	1.8			1.0	Stainless Steel SUS304	0,08	0,18
VB1R	Screwed R						50			2.0							

Y



Dimensions YM1

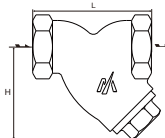

YSF-F

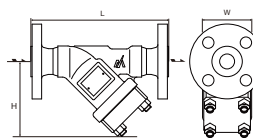

YSF-W

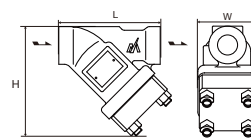

Model	Connections	Size	Max. Operating Pressure		Max. Operating Temperature		Mesh	Dimensions (mm)			Dimensions (in)			Body Material	Weight						
			MPa	psig	°C	°F		L	H	W	L	H	W		kg	lb					
YM1	Screwed Rc, NPT	1/2"	2,0	290	220	428	60	75	55		3.0	2.2		Ductile Cast Iron FCD450	0,5	1.1					
		3/4"						90	70		3.5	2.8			0,9	2.0					
		1"						110	85		4.3	3.3			1,4	3.1					
YSF-F	Flanged JIS, ASME, DIN	1/2"	4,9	710	425	800	60	230	125	82	9.1	4.9	3.2	Forged Steel A105	7,0	15.4					
		3/4" - 1"													8,0	17.6					
		1 1/4"																	Forged Steel S25C	16,0	35.3
YSF-W	Socket Weld JIS, ASME, DIN	1/2" - 1"	4,9	710	425	800	60	140	125	82	5.5	4.9	3.2	Forged Steel A105	5,0	11.0					
		1 1/4" - 2"																		Forged Steel S25C	9,5

Screwed (NPT) connection is available as special design.
For more details, please contact MIYAWAKI Inc, or an authorized representative.

Vacuum Breaker CV11, CVU15

CV11, CVU15



Capacity Chart CV11

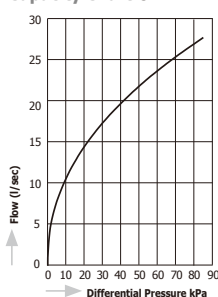

Capacity Chart CVU15

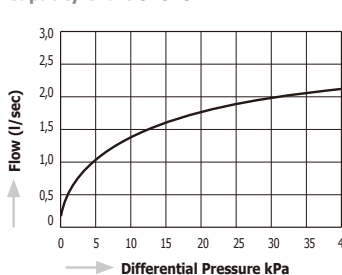

Dimensions CV11



CVU15

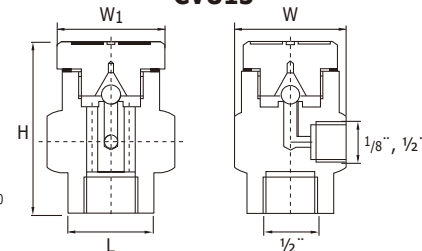

Model	Connections		Size	Max. Operating Pressure		Max. Operating Temperature		Dimensions (mm)					Dimensions (in)					Body Material	Weight				
				MPa	psig	°C	°F	L	H	W	W1	W2	L	H	W	W1	W2		kg	lb			
CV11	Male thread R		1/2"	0,9	130	150	302	130							5.1				Stainless Steel SUS304	0,8	1.8		
			3/4"					135							5.3							2.0	1.5
			1"					135							5.3								
CVU15	System connection	Air inlet connection	1/2" x 1/8"	2,1	305	450	842	32	55	41	36			1.26	2.17	1.61	1.42	Stainless Steel AISI 304 (DIN 1.4301)	0,4	1.0			
	1/2" Screwed (BSPP, BSPT, NPT)	1/8", 1/2" Screwed (BSPP, BSPT, NPT)	1/2" x 1/2"					70											2.75				0,6

Anti-Freezing Valve F1

F1

Features

1. Easy installation: compact in size
2. No adjustment
3. Easy maintenance

Suitable for

Discharge of remaining condensate out of steam traps and pipe lines

Capacity Chart F1

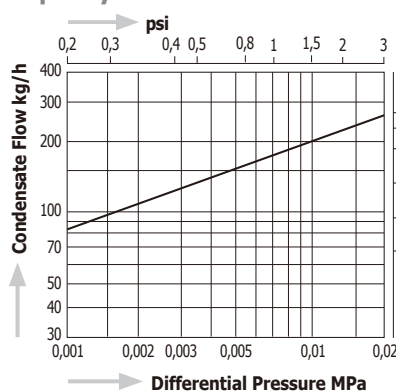

Dimensions F1B

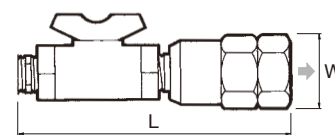

F1

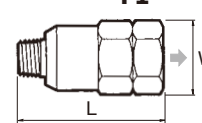

Model	Connection	Size	Max. Operating Pressure		Working Pressure				Max. Operating Temperature		Dimensions (mm)		Dimensions (in)		Body Material	Weight	
			MPa	psig	Opening	Closing	°C	°F	L	W	L	W	kg	lb			
F1B	Screwed Rc, NPT	1/4"	0,98	142	0,01 - 0,04	1.5 - 5.8	0,02 - 0,05	2.9 - 7.3	220	428	113	27	4.4	1.1	Brass C3604	0,2	0.4
		3/8"									119		4.7			0,2	0.5
F1	Screwed Inlet : R Outlet : Rc, NPT	1/4", 3/8"	1,6	230							52		2.0			0,1	0.3

TS1



Features

To check operation of steam traps

Suitable for

Steam and liquid lines

T3



Dimensions TS1

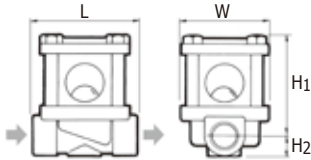

T3

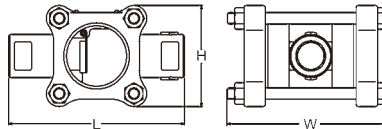

T3F

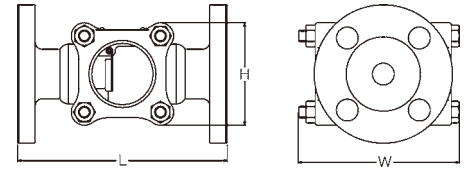

Model	Connect.	Size	Max. Operating Pressure		Max. Operating Temperature		Dimensions (mm)					Dimensions (in)					Body Material	Weight												
			MPa	psi	°C	°F	L	H	H1	H2	W	L	H	H1	H2	W		kg	lb											
TS1	Screwed Rc, NPT	1/2"	0,8 1,0	Steam Water	116 145	Steam Water	180 100	Steam Water	356 212	60	80	69	14	3.1	2.7	0.6	2.4	Brass C3771	0,8	1.8										
		3/4"									71	17	2.8		0.7	0,85			1.9											
		1"									85	76	21		3.4	3.0			0.8	1,2	2.2									
T3	Screwed Rc, NPT	1/2"	1,0		145		183		361		123	70	115	4.8	2.8		4.5	Cast Steel A216WCB	1,6	3.5										
		3/4", 1"									170	85							155	6.7	3.3	6.1	1,7	3.7						
		1 1/4"																					195	115	185	7.7	4.5	7.3	3,3	7.3
		1 1/2"																					Cast Iron FC200	3,2	7.1					
		2"																						7,3	16.1					
T3F	Flanged JIS, ASME, DIN	1/2"	1,0		145		183		361		144	70	115	5.7	2.8		4.5	Cast Steel A216WCB	3,3	7.3										
		3/4"									180	85							155	7.1	3.3	6.1	4,4	9.7						
		1"																					Cast Iron FC200	5,0	11.0					
		1 1/4"																						8,0	17.6					
		1 1/2"																						9,0	19.8					
		2"																						210	115	185	8.3	4.5	7.3	12,0

Spare Parts

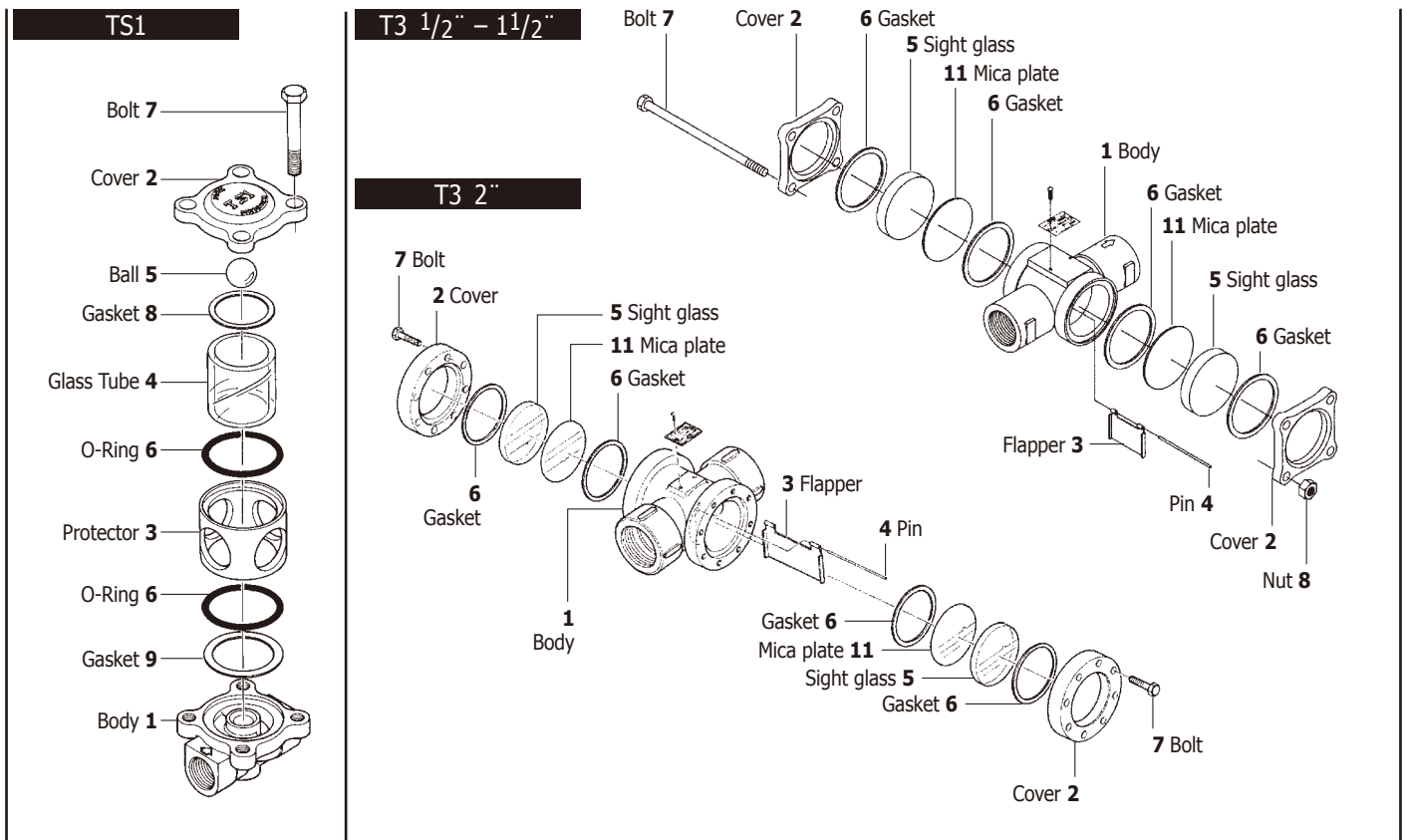

H3

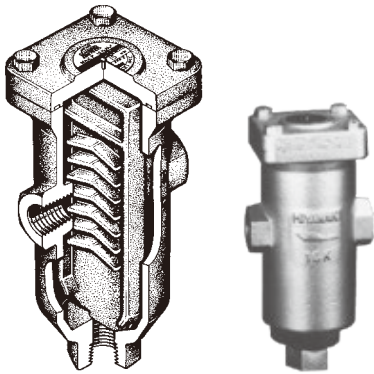

H5



H9XF

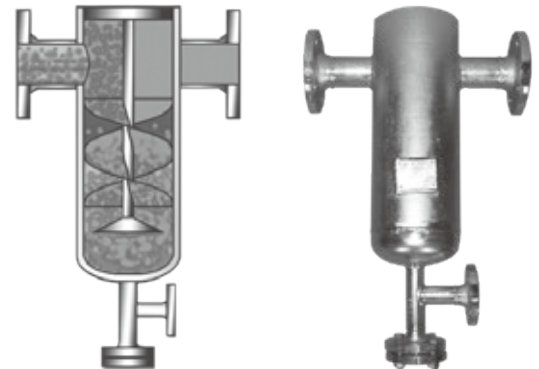

Features

1. Separates mist and condensate from steam and air lines
2. Compact size – easy installation together with Pressure Reducing Valves and Steam Traps
3. Very low pressure loss (0,002 MPa)

Suitable for

All steam and air lines

Dimensions

H3

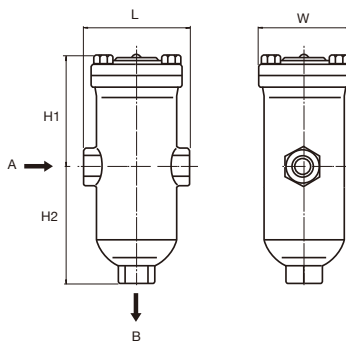

H5

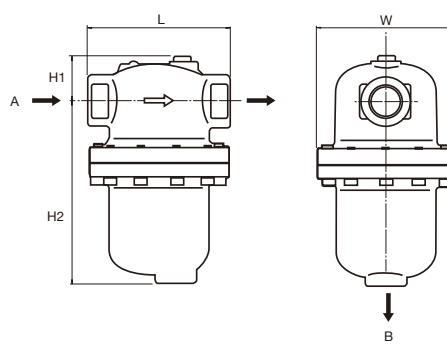

H9XF

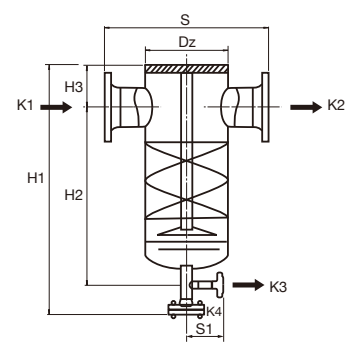

Model	Connections	Size (in)		Max. Operating Pressure		Max. Operating Temperature		Dimensions (mm)				Dimensions (in)				Body Material	Weight						
		A	B	MPa	psig	°C	°F	L	H1	H2	W	L	H1	H2	W		kg	lb					
H3	Screwed Rc, NPT	1/2"	1/2"	1,6	230	220	428	100	93	120	86	3.9	3.7	4.7	3.4	Ductile Cast Iron FCD450	3,6	7.9					
		3/4"	1/2"					130	120	158	108	5.1	4.7	6.2	4.3		6,7	14.7					
		1"	1/2"					160	130	180	128	6.3	5.1	7.1	5.0		9,4	20.7					
H5	Screwed Rc, NPT	1/2"	3/4"	2,0	290	220	428	150	50	193	146	5.9	2.0	7.6	5.7	Ductile Cast Iron FCD450	7,1	15.6					
		3/4"						190	69	213	175	7.5	2.7	8.4	6.9		7,3	16.1					
		1"						219	82	260	199	8.6	3.2	10.2	7.8		12,5	27.6					
		1 1/4"	1"																				
		1 1/2"																					
2"																							

Model	Connection	Size (DN)	PN	Inlet	Outlet	Condensate Outlet	Dirt Pocket	Dimensions (mm)					Dimensions (in)					Body Material	Weight			
				K1 (DN)	K2 (DN)	K3 (DN)	K4 (DN)	Dz	H1	H2	H3	S	S1	Dz	H1	H2	H3		S	S1	kg	lb
H9XF	Flanged DIN, ASME	15	16	15	15	15	15	88,9	360	240	50	240	90	3.5	14.2	9.4	2.0	9.4	3.5	Steel P265 GH	6,8	15.1
		20		20	20																7,3	16.1
		25		25	25																7,8	17.2
		32		32	32																12	26.4
		40		40	40																12,5	27.5
		50		50	50																26	57.2
		65		65	65																27	59.4
		80		80	80																29	63.8
		100		100	100																61	134.2
		125		125	125																65	143.0
		150		150	150																95	209.0
200	200	200	on request																			

Other pressure ratings (PN25, PN40), connections and body materials on request.

Steam Trap Survey Assistant

Dr. Trap® Jr.

PM15

It is the ideal partner for steam trap inspections.

PM15 is capable to work with most of the steam traps of the main manufacturers.



Ultrasonic Checker PM11



Temperature Probe



SurveyPro Light PM150 V2.0

Features PM15

The Steam Trap Ultrasonic Checker PM11 has been designed to assess the operating condition of steam traps during operation by measuring the vibration and the temperature of the surface.

- The system consists of the Ultrasonic Checker PM11, a Temperature Probe and the SurveyPro Light PM 150 Software version 2.0.
- Measures vibration and temperature at the same time
- The temperature probe can measure temperatures between 0°C and 250°C
- Estimates and displays the saturation pressure by measuring the temperature.
- Useful for testing not only steam traps, but also valves
- One key operation for all functions
- Long battery life – 40 hours or more of continuous use
- Shuts off automatically if the device is not in use for 5 minutes
- Includes a stop watch for monitoring periodic characteristics of vibrations
- Compact, lightweight and easy to carry

Software SurveyPro Light PM150 V2.0

Software for analyzing the data which had been measured by using the steam trap checker PM11 and for determining the condition of the steam trap.

- Standard and Special versions available
- Both versions allow the estimation of CO₂ emissions which correspond to leaking steam traps.
- Compatible with Windows 7, Windows 8/8.1 and Windows 10 – 32 and 64 bit versions.
- Full data compatibility. Data generated by the previous version can be integrated into the new software*
- The version 2.0 comes with an updated list of steam trap models of the main steam trap manufacturers.
- The updated software allows a better classification of steam traps to various groups and areas inside a plant with the possibility for more detailed analysis of selected groups or areas.

* For more details please contact MIYAWAKI Inc. or an authorized representative

Working Flow

<p>1 Tagging of Steam Traps</p> <p>Put a tag on or text to each trap in your factory, so that it can be easily identified any time.</p>	<p>2 Survey List set-up</p> <p>Run the Survey Pro Light software and fill in the basic information of the steam traps. Information such as survey list name, tag number, area, manufacturer, inlet pressure or size are filled in at this moment.</p>	<p>3 Traps inspection</p> <p>Diagnose each trap on site using the checker PM11. Write down the vibration data measured for each trap.</p>
<p>4 Filling out of Survey List</p> <p>Run again the Survey Pro Light software and enter the measured vibration data into the survey list for each trap. Once the vibration value of a trap has been entered, the operating condition of the trap will be displayed immediately. The list will also display the steam loss of each trap (if detected) and the related financial losses.</p>	<p>5 Analysis</p> <p>After entering all test results of the survey, the software can show an analysis for each trap type and manufacturer, an analysis of steam losses and related financial losses for each manufacturer and trap type, an analysis of CO₂ emission, or an analysis for kind of application (process, tracing, etc.), with the possibility of showing the results by areas or groups.</p>	<p>6 Trend Analysis</p> <p>Comparisons can be made by Manufacturer, by the installed types, by the pressure classification and by applications. In each case:</p> <ul style="list-style-type: none"> - the failure rate - the steam loss - and money loss tendencies will be shown.

Technical Specification

<p>Probes</p> <p>Vibration</p>	<p>Piezo-electric-ceramic acceleration sensor (10 kHz – 40 kHz)</p>	<p>Displays</p>	<p>Illuminated liquid crystal display (LCD)</p>
<p>Temperature</p>	<p>Thermistor Range: 0 – 250°C / 32 – 482°F</p>	<p>Housing</p>	<p>Heat-resistant plastic (ABS), simple waterproof design</p>
<p>Weight</p>	<p>230 g (incl. batteries)</p>	<p>Ambient working temperature</p>	<p>0 – 40°C (32 – 104°F)</p>
<p>Power supply</p>	<p>2 x 1.5V AA alkaline batteries (80 hours or more (45 hours or more with the LCD light on continuously.)) 2 x 1.2V AA NiMH (75 hours or more (40 hours or more with the LCD light on continuously.))</p>		

Steam Trap Survey Assistant

Dr. Trap® Jr.

SurveyPro Light PM150 V2.0

Main Functions – Standard Version

Survey List

ID	Survey List Name	Section	Group	Area	Event	Date	Type	Location
101	101 Section	101	101	101	Routine Survey	10/10/2011	Trap	Trap
102	102 Section	102	101	101	Routine Survey	10/10/2011	Trap	Trap
103	103 Section	103	101	101	Routine Survey	10/10/2011	Trap	Trap
104	104 Section	104	101	101	Routine Survey	10/10/2011	Trap	Trap
105	105 Section	105	101	101	Routine Survey	10/10/2011	Trap	Trap
106	106 Section	106	101	101	Routine Survey	10/10/2011	Trap	Trap
107	107 Section	107	101	101	Routine Survey	10/10/2011	Trap	Trap
108	108 Section	108	101	101	Routine Survey	10/10/2011	Trap	Trap
109	109 Section	109	101	101	Routine Survey	10/10/2011	Trap	Trap
110	110 Section	110	101	101	Routine Survey	10/10/2011	Trap	Trap

Analysis

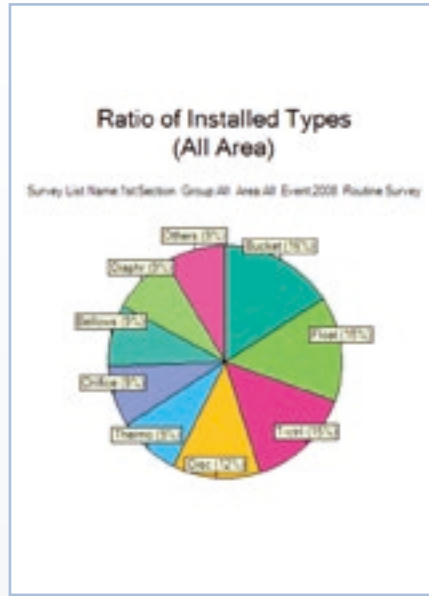

Trend Analysis

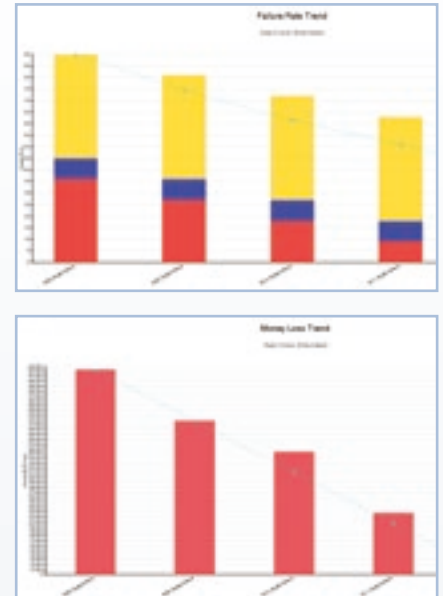

Additional Functions – Special Version

The Special Version includes the functions of the Standard Version plus the following ones:

Integration of multiple survey files into a single one

Repair Cost Management

Repair Efficiency

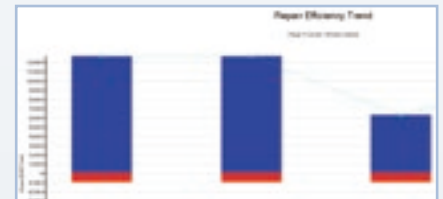

Management of other kind of failures

- Failure of inlet valve
- Failure of outlet valve
- Failure of other than valves

User and Ranking Summaries

Service Period

Average Consumption Cost

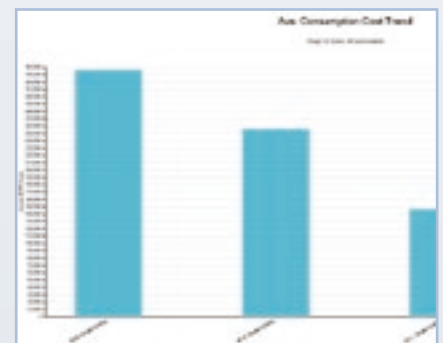

Steam Trap Management System

Dr. Trap®

PM500

Steam Trap Management System PM500

Checker (PM520)

It detects the vibration and temperature in steam traps at the same time.

The survey accuracy has been improved from the previous model (PM321) by MIYAWAKI's sensor technology.



Checker (PM520)



* Tablet to be prepared by customer
* For Windows® only

Trap Survey App (PM510)

Trap Survey App (PM510)

The App will be installed on a tablet computer, which must be prepared by the customer.

It displays and stores survey results transferred from the checker using Bluetooth connection.

Software SurveyPro 4.0 (PM530)

The software will be installed on a personal computer. It aggregates and analyzes steam trap data from the Trap Survey App, identifying faulty steam traps, providing steam loss and financial loss data and includes many other possibilities to manage the steam traps easily.

It provides detailed charts and graphs.



* Standard and Special versions available

Software SurveyPro 4.0 (PM530)

Features of PM500

- **High-speed survey**

The special design of the vibration sensor integrating a contact-type thermocouple sensor guarantees a high survey speed. Each steam trap will be surveyed within 2 seconds at the shortest, and 10 seconds at the maximum.

- **Improved survey accuracy**

The holding mechanism of the probe tip ensures a pressing force, which reduces the discrepancy of survey results substantially.

- **Simple operation**

The checker is ergonomic shaped to handle and operate with one hand. The survey will start automatically by simply pressing down the probe on the trap with minimum force. It is possible to proceed with the survey uninterruptedly without using the tablet.

- **Improved durability**

Dust and water protection : IP34 (Conforming to IEC 60529)
Drop test (Conforming to IEC 60068-2-31)

- **Estimation of CO₂ emissions**

The software can estimate CO₂ emissions based on steam trap leakage amounts.

- **Full data compatibility**

After converting survey data generated by the previous version (V3.1), the data can be integrated into the new software without any problems.

Technical Specifications

Hardware	Weight		Sensor		Ambient working temperature		Max. surface temperature		Power supply *not included in package	Continuous operating (approximately) Hours	Working survey time Seconds	Bluetooth	
	g	lb	Vibration	Temperature	°C	°F	°C	°F				Interface	Communication distance
Checker PM520	220	0.49	Piezo-electro-ceramic sensor	Type K thermocouple	-5 to +50	23 to 122	400	752	2 x 1.2V AA size NiMH	8 (discharged capacity: 1900mAh)	10 (2 minimum)	Ver. 2.1 + EDR SPP	Approx. 5 m
	excl. battery												

Accessory: 1 x Soft case

Display: Transmission type TFT color liquid crystal

Software	Medium	Environment						Others
		Operating System	CPU	Memory (RAM)	Hard disk	Display resolution (pixel)		
Trap Survey App PM510*	CD-ROM	Windows 7, Windows 8/8.1, Windows 10 (32 or 64 bit)	1.6GHz or more	4GB or more	20GB or more free space (excl. Data area)	1280 x 800 or more	Bluetooth: Ver.2.1 + EDR SPP Microsoft NET Framework 4.5 Microsoft SQL Server Compact 3.5 SP2	
SurveyPro PM530 V4.0			1GHz or more	1GB (64bit: 2GB) or more		1024 x 768 or more		Microsoft NET Framework 4.5 Microsoft SQL Server Compact 3.5 SP2 USB Port, CD Drive

* PM510 is to be installed on a tablet. The above specifications of PM510 are hardware requirement for the tablet.

Steam Trap Management System

Dr. Trap®

Trap Survey App PM510

The App displays and stores the survey results from the checker. It includes a lot of new and additional functions such as viewing and editing a survey map or a camera function. It can contribute to create a paperless environment. The available functions depend on the version of SurveyPro 4.0, standard or special.

Main Functions

Survey screen

The touch-screen tablet makes it easy to browse and edit a survey list. A lot of detailed information is available on the survey screen and can be edited there. The survey log information will be also displayed on the screen.

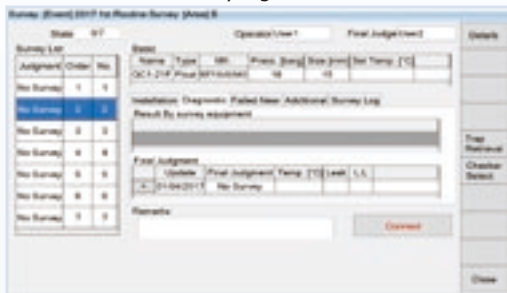

Survey map

A survey map can be displayed and edited on the tablet computer. The map can be associated with each steam trap on the survey list. Then, the order of the steam trap survey can be set.



Camera function

The camera function allows to take images and record videos on the Camera screen. It is possible to edit and save the images for each steam trap. The images and videos will be displayed on the detailed screen of each steam trap.

PM510 Function correspondence table

Several functions of PM510 are unavailable depending on the version of PM530.

[○] : Available, [-] : Unavailable

PM510 Function	PM530	
	Standard	Special
List Import/Export	○	○
List Retrieval	○	○
Edit Area	○	○
Survey	○	○
Survey map	-	○
Whole map	-	○
Edit Drawing	-	○
Camera	-	○

SurveyPro 4.0 PM530

The software was updated from SurveyPro V3.1. It offers to analyse survey data, view trends, and manage survey files. Same as V3.1, it displays various summary sheets and graphs depending on the purpose, and export them to Excel and image files. It helps to create survey reports. Standard and Special versions are available.

Upgraded Functions

Single Sheet

Each survey list can be displayed as a Single Sheet. Then, it can be exported to Excel as well. It is possible to browse and edit survey list detail information on the sheet at once.



Data Summary Sheet

Different from the previous version, SurveyPro V3.1, the data summary sheets will be displayed as one sheet. Consequently, it is easier to use various analysis functions to create summary sheets such as by Manufacturer and by Type.

The summaries of all data can be displayed in graphical form same as V3.1.

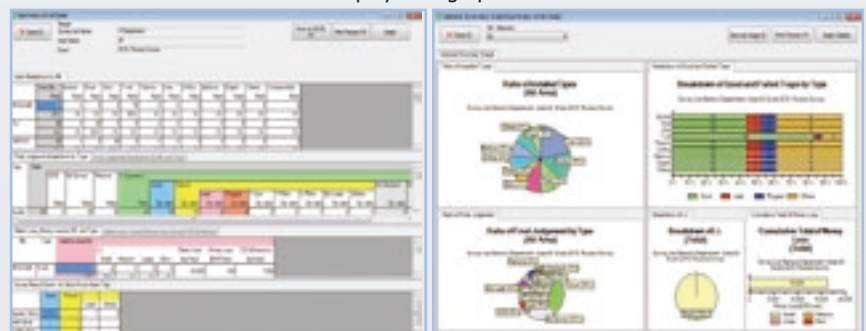

The MIYAWAKI SCCV®-System: worldwide patented

MIYAWAKI's internationally patented Self Closing and Centering Valve SCCV®-System has proven its high reliability and effectiveness during more than two decades. Many thousands of steam traps equipped with the SCCV®-System have proven enormous advantages for our customers:

1. A substantially longer service life compared with other steam traps
2. No partial or one-sided precipitate wear of valve and seat
3. Greatly reduced wear of all internal parts due to the reduction of the closing forces required to maintain a seal
4. No steam loss for all Temperature Control Traps

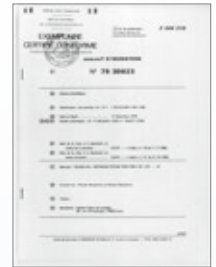

The MIYAWAKI SCCV®-System: variable adjusted to various types

Intensive research and development activities over many years have enabled MIYAWAKI to incorporate the SCCV®-System in various types of steam traps. Thus it became possible to adopt the SCCV®-System to a wide pressure range and to utilize the SCCV®-System not only for Bimetal Steam Traps, but also for Inverted Bucket and Float Type Steam Traps.

Inverted Bucket Steam Traps Series ES

The Valve Holder is fixed to a specially developed "Super-Lever". The Valve is "free floating" inside the Valve Holder. Thus the control space inside the Valve Holder decreases the force toward the seat caused by the movement of the bucket. The Valve will close softly and exactly in the center of the seat.

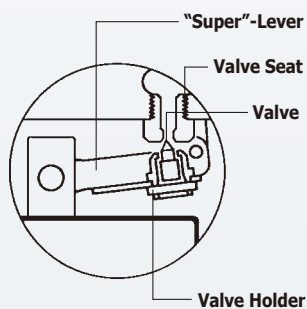

Inverted Bucket Steam Traps Series ER

The SCCV®-System is part of a "Double Valve Unit", which is operating on the basis of the pressure difference inside the unit. The trap is thus characterized by extended lifetime of the valve assembly and a greater condensate discharge per body size when compared to conventional inverted bucket steam traps.

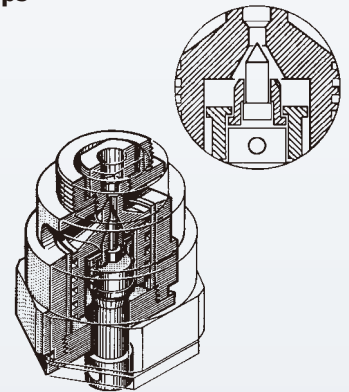

Ball Float Steam Trap G11N, G12N

The Valve (Ball) lies inside a Valve Holder, which is directly connected through a lever with the float. By installing a spring inside the Valve Holder the movements of the float and the forces caused by it will not be directly transferred to the Valve. This will increase the service life of the sealing surfaces.

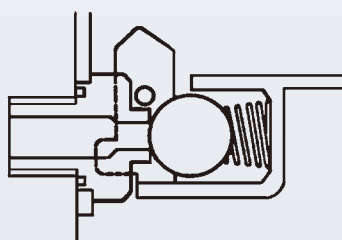

Temperature Control Steam Trap TB7N

The Bimetal Unit including the valve are guided inside the body. A spring reduces the force caused by the deflection of the bimetal which move the valve toward the seat. The guiding of the valve within the seat and the lift of the valve is designed in such a way that the valve will close very smoothly in the center of the seat.

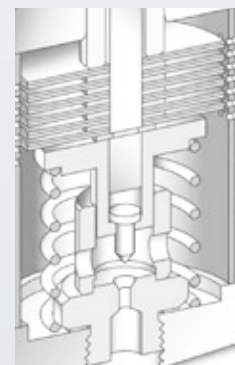

MIYAWAKI-Technology

SCCV®-System

Basic Principle

Regulating

The design of the Valve and Seat and the Valve lift (distance between the closed and open position of the valve) are calculated and designed in such a way that the valve closes its seat at the time that the condensate reaches the steam trap adjusted temperature.

Centering and Soft Closing

The valve is "free floating" inside the valve holder. The valve moves to the center caused by the pressure and the flow of condensate. The tip of the valve is drawn down to the center axis of the valve seat. A spring and a stop ring inside the control chamber absorb and soften the movement of the valve (caused by the temperature and pressure of the steam system) towards its seat. The centering and soft closing characteristics prevents premature or uneven wearing of the valve and its seat, extending the lifetime of the steam trap.

No Steam Loss

The valve closes exactly in the center of the seat at the adjusted temperature, slightly below the saturation temperature assuring Zero steam loss.

TB51

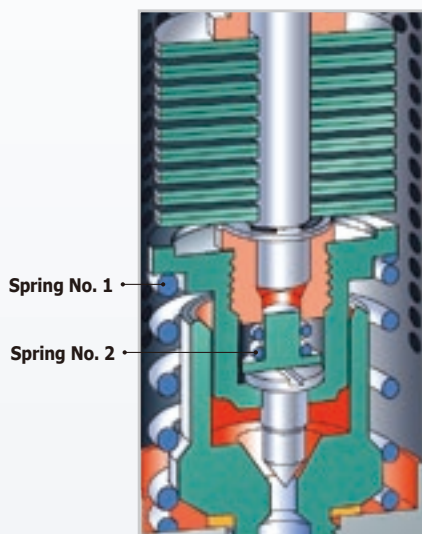

TB7N

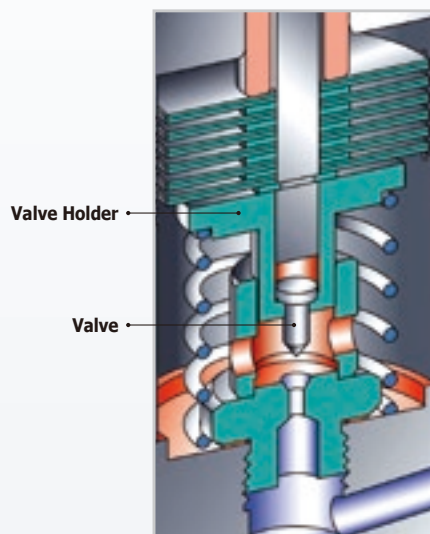

TB9N

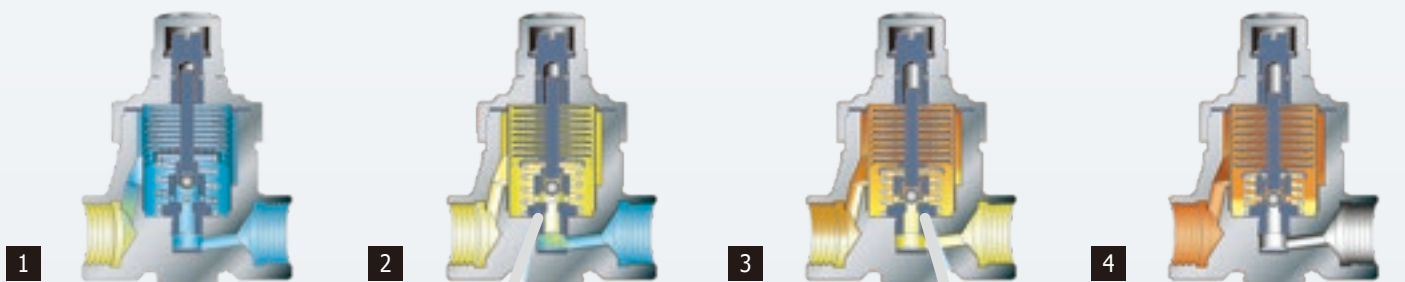
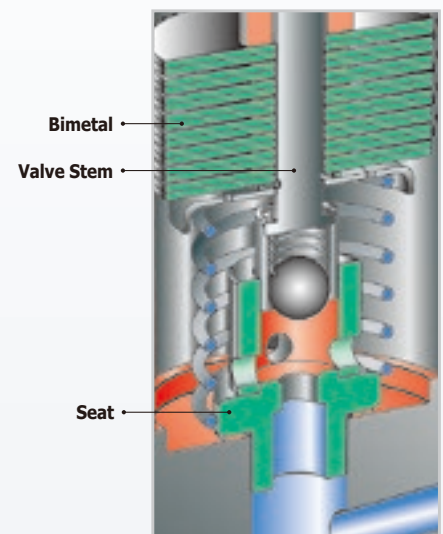

1 On start-up, the bimetal discs are all flat and the valve shaft is up with the valve fully open. Virtually all cold condensate and air are discharged.

2 As the temperature of the condensate increases, the bimetal discs begin to curve gradually and force the valve shaft and the valve holder to move down.

3 When condensate with higher temperature (near to set temperature) flows in, the bimetal discs are curved even more and, at the same time, the valve shaft moves down and the valve holder closes the holes in the guide partially.

4 In case of very low condensate flow, the holes in the guide are closed completely by the valve holder and the valve will close precisely in the center of the seat. Normally, the trap is filled with hot condensate and the operation will rest in the state shown in figure 3. Condensate will be discharged continuously.

Most of the condensate is still discharged quickly, since the valve and the holes in the fixed guide on the valve seat are still fully open.

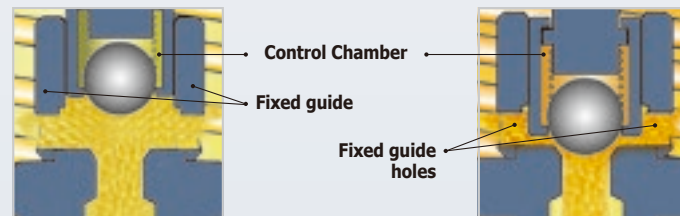

The amount of condensate being discharged is reduced quickly. This prolongs the time that the hot condensate stays near the bimetal discs and the heat of the condensate is transferred to the bimetal discs much more effectively.

Material Standards

Following you find a list of materials mainly used by MIYAWAKI for its Steam Traps, according to Japanese Standards and the most closely corresponding numbers of American (ASTM), European (EN) and German (DIN) Standards.

1. Iron Castings

JIS	ASTM	EN	DIN
FC200	A48 – class 30	EN-GJL-200	GG-20 (0.6020)
FC250	A48 – class 35	EN-GJL-250 (EN-JL 1040)	GG-25 (0.6025)
FCD400	A536-584 Gr.60-40-18	EN-GJS-400-15 (EN-JS1030)	GGG40 (0.7040)
FCD450	A536 65-45-12	EN-GJS-450-10 (EN-JS1040)	GGG40.3 (0.7043)

2. Steel Casting and Forgings

JIS	ASTM	EN	DIN
S25C	A181 Gr. I	C25E (1.1158)	Ck25
SCPH 2	A216WCB	GP240GH (1.0619)	GS-C25
SCPH 21	A217WC6	G17CrMo5-5 (1.7357)	GS17CrMo55 (1.7357)
SCPH32	A217WC9	GS12CrMo9-10 (1.7380)	10CrMo9-10 (1.7380)
SFVC2A	A105	P250GH (1.0460)	C22.8 (1.0460)
SFVAF22B	A182F22	10CrMo9-10 (1.7380)	10CrMo9-10 (1.7380)

3. Stainless and Heat Resisting Steels

JIS	ASTM	EN	DIN
SCS13	–	–	G-X6CrNi189 (1.4308)
SCS13A	A351CF8	GX5CrNi19-10 (1.4308)	G-X6CrNi189 (1.4308)
SCS14	A351CF8M	GX5CrNiMo19-11-2 (1.4408)	G-X6CrNiMo1810 (1.4408)
SUS303	A582S30300	X8CrNiS18-9 (1.4305)	X10CrNiS189 (1.4305)
SUS304	A276S30400	X5CrNi18-10 (1.4301)	X5CrNi1810 (1.4301)
SUSF304	A182F304	–	–
SUS316	A276316	X5CrNiMo17-12-2 (1.4401)	X2CrNiMo1810 (1.4401)
SUS321	A240 321	X6CrNiTi18-10 (1.4541)	X6CrNiTi18-10 (1.4541)
SUS403	A276S40300	X6Cr13 (1.4000)	X6Cr13 (1.4000)
SUS416	–	X12CrS13 (1.4005)	X12CrS13 (1.4005)
SUS420J2	–	X30Cr13 (1.4028)	X30Cr13 (1.4028)

4. Alloys

JIS	ASTM	EN	DIN
CAC502C	C90700	CuSn10-C (CC480K)	CuSn10-C (CC480K)
C3771	C37700 (B 124-89)	CuZn39Pb2 (CW612N)	CuZn39Pb2

Diameters and Drilling of Flanges

(see Page 97)

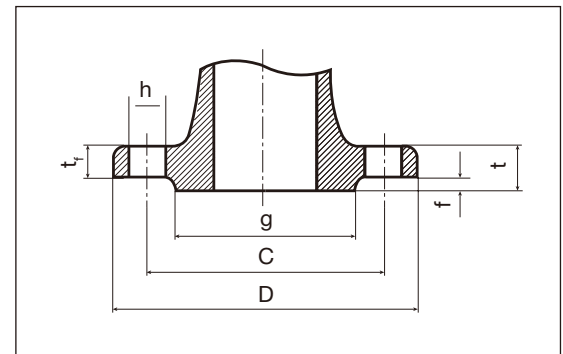

Conversion Factors

$$T_{°C} = \frac{5}{9}(T_{°F} - 32) \quad T_{°F} = 1,8 T_{°C} + 32$$

°C	°F	°F	°C	°F	°F
10,0	50	122	127	260	500
12,8	55	131	132	270	518
15,6	60	140	138	280	536
18,3	65	149	143	290	554
21,1	70	158	149	300	572
23,9	75	167	154	310	590
26,7	80	176	160	320	608
29,2	85	185	166	330	626
32,2	90	194	171	340	644
35,0	95	203	177	350	662
37,8	100	212	182	360	680
40,6	105	221	188	370	698
43	110	230	193	380	716
46	115	239	199	390	734
49	120	248	204	400	752
52	125	257	210	410	770
54	130	266	216	420	788
57	135	275	221	430	806
60	140	284	227	440	824
63	145	293	232	450	842
66	150	302	238	460	860
68	155	311	243	470	878
71	160	320	249	480	896
74	165	329	254	490	914
77	170	338	260	500	932
79	175	347	266	510	950
82	180	356	271	520	968
85	185	365	277	530	986
88	190	374	282	540	1004
91	195	383	288	550	1022
93	200	392	293	560	1040
99	210	410	299	570	1058
104	220	428	304	580	1076
110	230	446	310	590	1094
116	240	464	316	600	1112
121	250	482			

American Standard ASME B 16.5-2009

Size (in)	Dimensions	class 150		class 300		class 600		class 900		class 1500	
		in	mm	in	mm	in	mm	in	mm	in	mm
1/2"	D	3.5	90	3.75	95	3.75	95	4.75	120	4.75	120
	tr	0.38	9,6	0.5	12,7	0.56	14,3	0.88	22,3	0.88	22,3
	f	0.06	2	0.06	2	0.25	7	0.25	7	0.25	7
	g	1.38	34,9	1.38	34,9	1.38	34,9	1.38	34,9	1.38	34,9
	C	2.38	60,3	2.62	66,7	2.62	66,7	3.25	82,6	3.25	82,6
	n x h	4 x 5/8	4 x 15,9	4 x 5/8	4 x 15,9	4 x 5/8	4 x 15,9	4 x 7/8	4 x 22,2	4 x 7/8	4 x 22,2
3/4"	D	3.88	100	4.62	115	4.62	115	5.12	130	5.12	130
	t	0.44	11,2	0.56	14,3	0.62	15,9	1	25,4	1	25,4
	f	0.06	2	0.06	2	0.25	7	0.25	7	0.25	7
	g	1.69	42,9	1.69	42,9	1.69	42,9	1.69	42,9	1.69	42,9
	C	2.75	69,9	3.25	82,6	3.25	82,6	3.5	88,9	3.5	88,9
	n x h	4 x 5/8	4 x 15,9	4 x 3/4	4 x 19,0	4 x 3/4	4 x 19,0	4 x 7/8	4 x 22,2	4 x 7/8	4 x 22,2
1"	D	4.25	110	4.88	125	4.88	125	5.88	150	5.88	150
	t	0.5	12,7	0.62	15,9	0.69	17,5	1.12	28,6	1.12	28,6
	f	0.06	2	0.06	2	0.25	7	0.25	7	0.25	7
	g	2	50,8	2	50,8	2	50,8	2	50,8	2	50,8
	C	3.12	79,4	3.5	88,9	3.5	88,9	4	101,6	4	101,6
	n x h	4 x 5/8	4 x 15,9	4 x 3/4	4 x 19,0	4 x 3/4	4 x 19,0	4 x 1	4 x 25,4	4 x 1	4 x 25,4
1 1/4"	D	4.62	115	5.25	135	5.25	135	6.25	160	6.25	160
	t	0.56	14,3	0.69	17,5	0.81	20,7	1.12	28,6	1.12	28,6
	f	0.06	2	0.06	2	0.25	7	0.25	7	0.25	7
	g	2.5	63,5	2.5	63,5	2.5	63,5	2.5	63,5	2.5	63,5
	C	3.5	88,9	3.88	98,4	3.88	98,4	4.38	111,1	4.38	111,1
	n x h	4 x 5/8	4 x 15,9	4 x 3/4	4 x 19,0	4 x 3/4	4 x 19,0	4 x 1	4 x 25,4	4 x 1	4 x 25,4
1 1/2"	D	5	125	6.12	155	6.12	155	7	180	7	180
	t	0.62	15,9	0.75	19,1	0.88	22,3	1.25	31,8	1.25	31,8
	f	0.06	2	0.06	2	0.25	7	0.25	7	0.25	7
	g	2.88	73	2.88	73	2.88	73	2.88	73	2.88	73
	C	3.88	98,4	4.5	114,3	4.5	114,3	4.88	123,8	4.88	123,8
	n x h	4 x 5/8	4 x 15,9	4 x 7/8	4 x 22,2	4 x 7/8	4 x 22,2	4 x 1 1/8	4 x 28,6	4 x 1 1/8	4 x 28,6
2"	D	6	150	6.5	165	6.5	165	8.5	215	8.5	215
	t	0.69	17,5	0.81	20,7	1	25,4	1.5	38,1	1.5	38,1
	f	0.06	2	0.06	2	0.25	7	0.25	7	0.25	7
	g	3.62	92,1	3.62	92,1	3.62	92,1	3.62	92,1	3.62	92,1
	C	4.75	120,7	5	127	5	127	6.5	165,1	6.5	165,1
	n x h	4 x 3/4	4 x 19,0	8 x 3/4	8 x 19,0	8 x 3/4	8 x 19,0	8 x 1	8 x 25,4	8 x 1	8 x 25,4

Japanese Standard: JIS B 2210 – 1984

Size (in)	Dimensions	Dimensions at Pressure Rating (mm)					
		10 K	16 K	20 K	30 K	40 K	63 K
1/2"	D	95	95	95	115	115	120
	t	12	12	14	18	20	23
	f	1	1	1	1	1	1
	g	51	51	51	55	55	55
	C	70	70	70	80	80	80
	n x h	4 x 15	4 x 15	4 x 15	4 x 19	4 x 19	4 x 19
3/4"	D	100	100	100	120	120	135
	t	14	14	16	18	20	25
	f	1	1	1	1	1	1
	g	56	56	56	60	60	60
	C	75	75	75	85	85	95
	n x h	4 x 15	4 x 15	4 x 15	4 x 19	4 x 19	4 x 23
1"	D	125	125	125	130	130	140
	t	14	14	16	20	22	27
	f	1	1	1	1	1	1
	g	67	67	67	70	70	70
	C	90	90	90	95	95	100
	n x h	4 x 19	4 x 19	4 x 19	4 x 19	4 x 19	4 x 23
1 1/4"	D	135	135	135	140	140	150
	t	16	16	18	22	24	30
	f	2	2	2	2	2	2
	g	76	76	76	80	80	80
	C	100	100	100	105	105	110
	n x h	4 x 19	4 x 19	4 x 19	4 x 19	4 x 19	4 x 23
1 1/2"	D	140	140	140	160	160	175
	t	16	16	18	22	24	32
	f	2	2	2	2	2	2
	g	81	81	81	90	90	90
	C	105	105	105	120	120	130
	n x h	4 x 19	4 x 19	4 x 19	4 x 23	4 x 23	4 x 25
2"	D	155	155	155	165	165	185
	t	16	16	18	22	26	34
	f	2	2	2	2	2	2
	g	96	96	96	105	105	105
	C	120	120	120	130	130	145
	n x h	4 x 19	8 x 19	8 x 19	8 x 19	8 x 19	8 x 23

European Standard EN 1092-1

Size (in)	Dimensions	PN 10	PN 16	PN 25	PN 40	PN 63	PN 100
		mm	mm	mm	mm	mm	mm
DN15	D	95	95	95	95	105	105
	t	16	16	16	16	20	20
	f	2	2	2	2	2	2
	g	45	45	45	45	45	45
	C	65	65	65	65	75	75
	n x h	4 x 14	4 x 14	4 x 14	4 x 14	4 x 14	4 x 14
DN20	D	105	105	105	105	130	130
	t	18	18	18	18	22	22
	f	2	2	2	2	2	2
	g	58	58	58	58	58	58
	C	75	75	75	75	90	90
	n x h	4 x 14	4 x 14	4 x 14	4 x 14	4 x 18	4 x 18
DN25	D	115	115	115	115	140	140
	t	18	18	18	18	24	24
	f	2	2	2	2	2	2
	g	68	68	68	68	68	68
	C	85	85	85	85	100	100
	n x h	4 x 14	4 x 14	4 x 14	4 x 14	4 x 18	4 x 18
DN32	D	140	140	140	140	155	155
	t	18	18	18	18	24	24
	f	2	2	2	2	2	2
	g	78	78	78	78	78	78
	C	100	100	100	100	110	110
	n x h	4 x 18	4 x 18	4 x 18	4 x 18	4 x 22	4 x 22
DN40	D	150	150	150	150	170	170
	t	18	18	18	18	26	26
	f	3	3	3	3	3	3
	g	88	88	88	88	88	88
	C	110	110	110	110	125	125
	n x h	4 x 18	4 x 18	4 x 18	4 x 18	4 x 22	4 x 22
DN50	D	165	165	165	165	180	195
	t	18	18	20	20	26	28
	f	3	3	3	3	3	3
	g	102	102	102	102	102	102
	C	125	125	125	125	135	145
	n x h	4 x 18	4 x 18	4 x 18	4 x 18	4 x 22	4 x 26

Pressure

Conversion Table from psi to bar

psi	bar	psi	bar	psi	bar	psi	bar	psi	bar	psi	bar
1	0,07	105	7,24	310	21,37	510	35,17	820	56,55	1250	86,19
1,5	0,1	108,8	7,5	319,0	22,0	514,8	35,5	826,5	57,0	1276	88,0
5	0,34	110	7,58	320	22,06	520	35,86	840	57,93	1300	89,66
7,3	0,5	116,0	8,0	326,3	22,5	522,0	36,0	855,5	59,0	1305	90,0
10	0,69	120	8,27	330	22,75	530	36,55	860	59,31	1350	93,08
14,5	1,0	123,3	8,5	333,5	23,0	536,5	37,0	870,0	60,0	1378	95,0
15	1,03	130	8,96	340	23,44	540	37,24	880	60,69	1400	96,55
18,9	1,3	130,5	9,0	348,0	24,00	543,8	37,5	899,0	62,0	1407	97,0
20	1,38	140	9,65	350	24,13	550	37,92	900	62,06	1450	100,00
21,8	1,5	145,0	10,00	355,3	24,5	551,0	38,0	913,5	63,0	1479	102,0
25	1,72	150	10,34	360	24,82	560	38,62	920	63,45	1500	103,45
29,0	2,0	159,5	11,0	362,5	25,0	565,5	39,0	928,0	64,0	1523	105,0
30	2,07	160	11,03	370	25,51	570	39,31	940	64,83	1550	106,87
33,4	2,3	166,8	11,5	377,0	26,00	572,8	39,5	942,5	65,0	1595	110,0
35	2,41	170	11,72	380	26,20	580	40,00	960	66,21	1600	110,32
36,3	2,5	174,0	12,0	384,3	26,5	587,3	40,5	971,5	67,0	1624	112,0
40	2,76	180	12,41	390	26,89	590	40,69	980	67,59	1650	113,77
43,5	3,0	188,5	13,0	391,5	27,0	594,5	41,0	986,0	68,0	1668	115,0
45	3,10	190	13,10	400	27,85	600	41,37	1000	68,95	1700	117,22
47,9	3,3	195,8	13,5	406,0	28,0	609,0	42,0	1015	70,0	1711	118,0
50	3,45	200	13,79	410	28,27	620	42,76	1020	70,34	1750	120,66
50,8	3,5	203,0	14,0	413,3	28,5	623,5	43,0	1029	71,0	1784	123,0
55	3,79	210	14,48	420	28,96	640	44,14	1040	71,72	1800	124,11
58,0	4,0	217,5	15,0	420,5	29,0	652,5	45,0	1044	72,0	1813	125,0
60	4,14	220	15,17	430	29,65	660	45,52	1060	73,10	1850	127,56
62,4	4,3	224,8	15,5	435,0	30,0	667,0	46,0	1073	74,0	1885	130,0
65	4,48	230	15,86	440	30,34	680	46,90	1080	74,48	1900	131,01
65,3	4,5	232,0	16,0	449,5	31,0	696,0	48,0	1088	75,0	1929	133,0
70	4,83	240	16,55	450	31,03	700	48,27	1100	75,86	1950	134,45
72,5	5,0	246,5	17,0	456,8	31,5	710,5	49,0	1117	77,0	1958	135,0
75	5,17	250	17,24	460	31,72	720	49,66	1120	77,24	2000	137,90
79,8	5,5	253,8	17,5	464,0	32,0	725,0	50,0	1131	78,0	2030	140,0
80	5,52	260	17,93	470	32,41	740	51,03	1140	78,62	2050	141,35
82,7	5,7	261,0	18,0	478,5	33,0	754,0	52,0	1146	79,0	2074	143,0
85	5,86	270	18,62	480	33,10	760	52,41	1160	80,00	2100	144,80
87,0	6,0	275,5	19,0	485,8	33,5	768,5	53,0	1175	81,0	2103	145,0
90	6,21	280	19,31	490	33,79	780	53,79	1180	81,38	2150	148,24
94,3	6,5	282,8	19,5	493,0	34,0	797,5	55,0	1189	82,0	2175	150,0
95	6,55	290	20,00	500	34,48	800	55,16	1200	82,76	2200	151,69
97,2	6,7	297,3	20,5	507,5	35,0	812	56,0	1233	85,0	2320	160,0
100	6,9	300	20,69								
101,5	7,0	304,5	21,0								

Conversion Factors

Units of measurement								
Pa	kPa	MPa	bar	kg/cm ²	atm	mm H2O	mm Hg (Torr)	lbf/in ² (psi)
1	0,001	1 x 10 ⁻⁶	1 x 10 ⁻⁵	1,01972 x 10 ⁻⁵	9,86923 x 10 ⁻⁶	0,101972	7,50062 x 10 ⁻³	1,450377 x 10 ⁻⁴
1000	1	0,001	0,01	0,0101972	9,86923 x 10 ⁻³	101,972	7,50062	0,1450377
1 x 10 ⁶	1000	1	10	10,1972	9,86923	1,01972 x 10 ⁵	7500,62	145,0377
1 x 10 ⁵	100	0,1	1	1,01972	0,986923	1,01972 x 10 ⁴	750,062	14,50377
9,80665 x 10 ⁴	98,0665	0,0980665	0,980665	1	0,967841	10000	735,559	14,22334
1,01325 x 10 ⁵	101,325	0,101325	1,01325	1,03323	1	10332,3	760,000	14,69595
9,80665	9,80665 x 10 ⁻³	9,80665 x 10 ⁻⁶	9,80665 x 10 ⁻⁵	0,0001	9,67841 x 10 ⁻⁵	1	0,0735559	0,001422334
133,322	0,133322	1,33222 x 10 ⁻⁴	0,00133322	0,00135951	0,00131579	13,5951	1	0,01933678
6894,76	6,89476	0,00689476	0,0689476	0,0703070	0,0680460	703,070	51,7149	1

Properties of Saturated Steam

Absolute Pressure	Saturation Temperature	Steam Volume	Steam Density	Sensible Heat	Total Steam Heat	Latent Heat
p MPa	t _s °C	v ^{''} m ³ /kg	ρ ^{''} kg/m ³	h ['] kJ/kg	h ^{''} kJ/kg	r = h ^{''} - h ['] kJ/kg
0,1	99,63	1,6940	0,5904	417,51	2.675,4	2.257,9
0,15	111,37	1,1590	0,8628	467,13	2.693,4	2.226,3
0,2	120,23	0,8854	1,1290	504,70	2.706,3	2.201,6
0,25	127,43	0,7184	1,3920	535,34	2.716,4	2.181,1
0,3	133,54	0,6056	1,6510	561,43	2.724,7	2.163,3
0,35	138,87	0,5240	1,9080	584,27	2.731,6	2.147,3
0,4	143,62	0,4622	2,1630	604,67	2.737,6	2.132,9
0,45	147,92	0,4138	2,4170	623,16	2.742,9	2.119,7
0,5	151,84	0,3747	2,6690	640,12	2.747,5	2.107,4
0,55	155,46	0,3426	2,9200	655,78	2.751,7	2.095,9
0,6	158,84	0,3155	3,1700	670,42	2.755,5	2.085,1
0,65	161,99	0,2925	3,4190	684,12	2.758,8	2.074,7
0,7	164,96	0,2727	3,6670	697,06	2.762,0	2.064,9
0,75	167,75	0,2554	3,9150	709,29	2.764,8	2.055,5
0,8	170,41	0,2403	4,1620	720,94	2.767,5	2.046,6
0,85	172,94	0,2268	4,4090	732,02	2.769,9	2.037,9
0,9	175,36	0,2148	4,6550	742,64	2.772,1	2.029,5
0,95	177,66	0,2040	4,9010	752,81	2.774,2	2.021,4
1,0	179,88	0,1930	5,1470	762,61	2.776,2	2.013,6
1,1	184,07	0,1747	5,6370	781,13	2.779,7	1.998,6
1,2	187,96	0,1632	6,1270	798,43	2.782,7	1.984,3
1,3	191,61	0,1511	6,6170	814,70	2.785,4	1.970,7
1,4	195,04	0,1407	7,1060	830,08	2.787,8	1.957,7
1,5	198,29	0,1317	7,5960	844,67	2.789,9	1.945,2
1,6	201,37	0,1237	8,0850	858,56	2.791,7	1.933,1
1,7	204,31	0,1166	8,5750	871,84	2.793,4	1.921,6
1,8	207,11	0,1103	9,0650	884,58	2.794,8	1.910,2
1,9	209,80	0,1047	9,5550	896,81	2.796,1	1.899,3
2,0	212,37	0,0996	10,0500	908,59	2.797,2	1.888,6
2,2	217,24	0,0907	11,0300	930,95	2.799,1	1.868,2
2,4	221,78	0,0832	12,0200	951,93	2.800,4	1.848,5
2,6	226,04	0,0769	13,0100	971,72	2.801,4	1.829,7
2,8	230,05	0,0714	14,0100	990,48	2.802,0	1.811,5
3,0	233,84	0,0666	15,0100	1.008,40	2.802,3	1.793,9
3,2	237,45	0,0624	16,0200	1.025,40	2.802,3	1.776,9
3,4	240,88	0,0587	17,0300	1.041,80	2.802,1	1.760,3
3,6	244,16	0,0554	18,0500	1.057,60	2.801,7	1.744,1
3,8	247,31	0,0524	19,0700	1.072,70	2.801,1	1.728,4
4,0	250,33	0,0498	20,1000	1.087,40	2.800,3	1.712,9
5,0	263,91	0,0394	25,3600	1.154,50	2.794,2	1.639,7
6,0	275,55	0,0324	30,8300	1.213,70	2.785,0	1.571,3
7,0	285,79	0,0274	36,5300	1.267,40	2.773,5	1.506,1
8,0	294,97	0,0235	42,5100	1.317,10	2.759,9	1.442,8
9,0	303,31	0,0205	46,7900	1.363,70	2.744,6	1.380,9
10,0	310,96	0,0180	55,4300	1.408,00	2.727,7	1.319,7
11,0	318,05	0,0160	62,4800	1.450,60	2.709,3	1.258,7
12,0	324,65	0,0143	70,0100	1.491,80	2.689,2	1.197,4
13,0	330,83	0,0128	78,1400	1.532,00	2.667,0	1.135,0
14,0	336,64	0,0115	86,9900	1.571,60	2.642,4	1.070,8
15,0	342,13	0,0103	86,7100	1.611,00	2.615,0	1.004,0
16,0	347,33	0,0093	107,4000	1.650,50	2.584,9	934,4
17,0	352,26	0,0084	119,5000	1.691,70	2.551,6	859,9
18,0	356,96	0,0075	133,4000	1.734,80	2.513,9	779,1
19,0	361,43	0,0067	149,8000	1.778,70	2.470,6	691,9
20,0	365,70	0,0059	170,2000	1.826,50	2.418,4	591,9
22,0	373,69	0,0037	268,3000	2.011,10	2.195,6	184,5
22,12	374,15	0,0032	315,5000	2.107,40	2.107,4	0,0



Environmentally friendly through reduced energy usage and improved steam efficiency

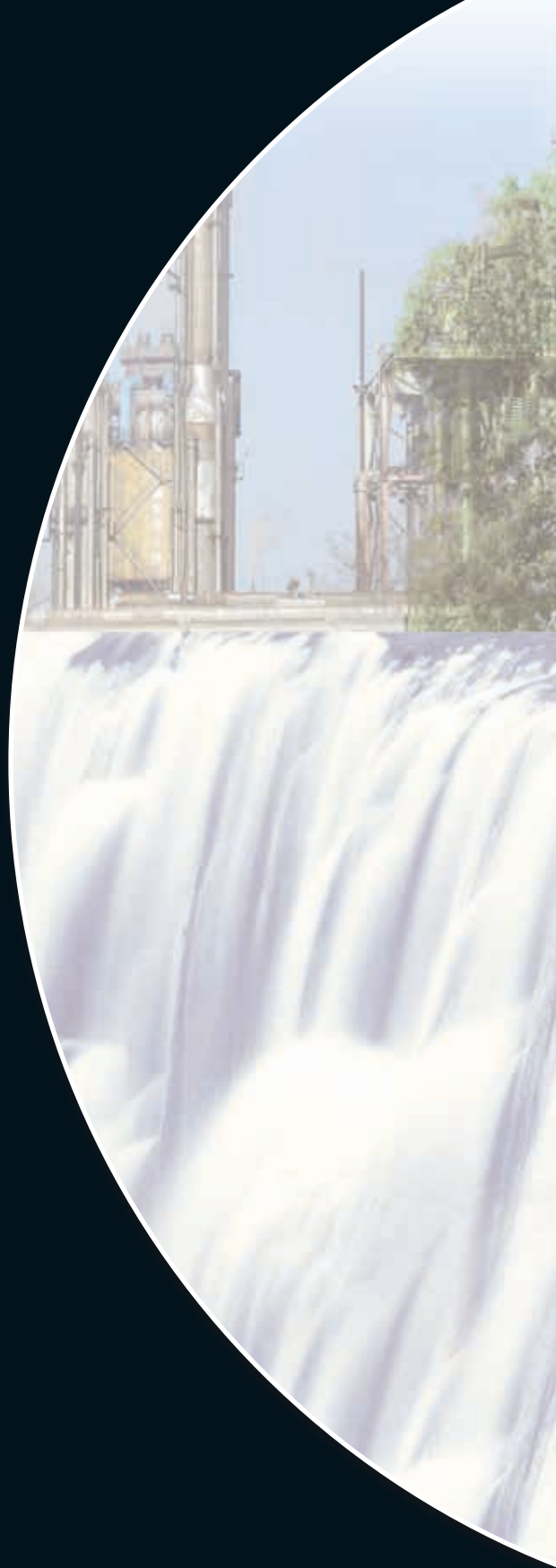

MIYAWAKI Inc.

2-1-30, Tagawakita, Yodogawa-ku
Osaka 532-0021
JAPAN

Tel.: + 81 - 6 - 6302 - 5549
Fax: + 81 - 6 - 6305 - 7155
E-Mail: export@miyawaki-inc.co.jp
Website: www.miyawaki-inc.com/en/



MIYAWAKI GmbH

Birnbaumsmühle 65
15234 Frankfurt (Oder)
GERMANY

Tel.: + 49 - 335 - 4007 0097
E-Mail: info@miyawaki.de
Website: www.miyawaki-inc.com/en/